

Poly318.com

TorqueFlite A727
TorqueFlite A904

Automatic Transmission
Factory Service Manual

1962 - 1965

Chrysler, Dodge, Plymouth

Contents

(PDF Page Numbers)

Diagnostics	2
Circuits & Operation	8
A727 & A904 Service	21
Specifications	80

PART II

TORQUEFLITE TRANSMISSION (TORQUE CONVERTER) (A-904-G, A-904-LA, A-727-A AND B)

Description

Three different TorqueFlite Transmissions are used in the Plymouth Vehicles (Figs. 1 and 2). Their usage is determined by the type of engine with which it is installed. Identification markings shown in the following application chart are cast in raised letters about $\frac{3}{8}$ inch high on the lower left side of the bell housing.

TRANSMISSION APPLICATION CHART

Engine Type	Displacement Cubic Inch	Identification Marking
6 Cyl.	170-225	A-904-G
8 Cyl.	273	A-904-LA
8 Cyl.	318	A-727-A
8 Cyl.	361-383-426	A-727-B

The A-727-A, mounted with an adapter plate between the transmission and engine, is available for heavy duty police and taxi service with the 6 Cyl., 225 Cu. In. engine.

Because of the similarity in design and in servicing the three transmissions, the procedures have been combined in this Manual. Where variations in procedures occur, application to the A-904-G, A-904-LA or A-727-A and B is indicated.

CAUTION: Transmission operation requirements are different for some vehicles due to high performance engines or special equipment applications. Therefore, some internal part will be different from standard to provide the desired transmission operation. These "special" parts are listed in

applicable Parts Catalog; therefore, be sure they are used when replacement is necessary.

The transmission combines a torque converter with a fully-automatic 3-speed gear system (Figs. 1 and 2). The torque converter housing and transmission case are an integral aluminum casting. The transmission consists of two multiple disc clutches, an over-running clutch, two servos and bands, and two planetary gear sets to provide three forward ratios and a reverse ratio. The common sun gear of the planetary gear sets is connected to the front clutch by a driving shell which is splined to the sun gear and to the front clutch retainer. The hydraulic system consists of a front and rear pump, and a single valve body which contains all of the valves except the governor valve.

Venting of the transmission is accomplished by a drilled passage through the upper part of the front oil pump housing.

The torque converter is attached to the crankshaft through a flexible driving plate. Cooling of the converter is accomplished by circulating the transmission fluid through an oil-to-water type cooler, located in the radiator lower tank. The torque converter assembly is a sealed unit which cannot be disassembled.

The transmission fluid is filtered by an internal "Dacron Type" filter attached to the lower side of the valve body assembly.

Engine torque is transmitted to the torque converter then, through the input shaft to the multiple disc clutches in the transmission. The power flow depends on the application of the clutches and bands. Refer to "Clutch Engagement and Band Application Chart.

SERVICE DIAGNOSIS**TORQUEFLITE TRANSMISSION**

NOTE: The transmission should not be removed nor disassembled until a careful diagnosis is made, the definite cause determined and all possible external corrections performed. In diagnosing any abnormal shift condition, always make the hydraulic pressures test before disassembly or replacement of parts.

Condition	Possible Cause	Correction
HARSH ENGAGEMENT IN D, 1, 2 AND R	(a) Engine idle speed too high. (b) Hydraulic pressures too high or low.	(a) Adjust the engine idle speed to 500 rpm. Readjust throttle linkage. (b) Check fluid level, then perform hydraulic pressure tests and adjust to specifications.

Condition	Possible Cause	Correction
	(c) Low-reverse band out of adjustment. (d) Valve body malfunction or leakage.	(c) Adjust the low-reverse band. (d) Perform pressure tests to determine cause and correct as required.
	(e) Accumulator sticking, broken rings or spring.	(e) Inspect the accumulator for sticking, broken rings or spring. Repair as required.
	(f) Low-reverse servo, band or linkage malfunction.	(f) Inspect the servo for damaged seals, binding. Repair as required.
	(g) Worn or faulty front and/or rear clutch.	(g) Disassemble and inspect clutch. Repair or replace as required.
DELAYED ENGAGEMENT IN D, 1, 2 AND R	(a) Low fluid level. (b) Incorrect control cable adjustment. (c) Oil filter clogged. (d) Hydraulic pressures too high or low. (e) Valve body malfunction or leakage. (f) Accumulator sticking, broken rings or spring. (g) Clutches or servos sticking or not operating. (h) Faulty front pump. (i) Worn or faulty front and/or rear clutch. (j) Worn or broken input shaft and/or reaction shaft support seal rings. (k) Aerated fluid.	(a) Refill to correct level with Automatic Transmission Fluid Type A, Suffix A. (b) Adjust the control cable. (c) Replace the oil filler. (d) Perform the hydraulic pressure tests and adjust to specifications. (e) Perform pressure tests to determine cause and correct as required. (f) Inspect the accumulator for sticking, broken rings or spring. Repair as required. (g) Remove the valve body assembly and perform air pressure tests. Repair as required. (h) Perform the hydraulic pressure tests. Adjust or repair as required. (i) Disassemble and inspect clutch. Repair or replace as required. (j) Inspect and replace the seal ring as required, also inspect respective bores for wear. Replace the parts as required. (k) Inspect for air leakage into the front pump suction passages.
RUNAWAY OR HARSH UPSHIFT AND 3-2 KICKDOWN	(a) Low fluid level. (b) Incorrect throttle linkage adjustment. (c) Hydraulic pressures too high or low. (d) Kickdown band out of adjustment. (e) Valve body malfunction or leakage. (f) Governor malfunction. (g) Accumulator sticking, broken rings or spring. (h) Clutches or servos sticking or not operating. (i) Kickdown servo, band or linkage malfunction. (j) Worn or faulty front clutch. (k) Worn or broken input shaft and/or reaction shaft support seal rings.	(a) Refill to correct level with Automatic Transmission Fluid, Type A, Suffix A. (b) Adjust the throttle linkage. (c) Perform the hydraulic pressure tests and adjust to specifications. (d) Adjust the kickdown band. (e) Perform pressure tests to determine cause and correct as required. (f) Inspect the governor and repair as required. (g) Inspect the accumulator for sticking, broken rings or spring. Repair as required. (h) Remove the valve body assembly and perform the air pressure tests. Repair as required. (i) Inspect the servo for sticking, broken seal rings, binding linkage or faulty band, lining. Repair as required. (j) Disassemble and inspect clutch. Repair or replace as required. (k) Inspect and replace seal rings as required, also inspect the respective bores for wear. Replace parts as required.
NO UPSHIFT	(a) Low fluid level.	(a) Refill to correct level with Automatic Transmission Fluid Type A, Suffix A.

Condition	Possible Cause	Correction
	(b) Incorrect throttle linkage adjustment. (c) Kickdown band out of adjustment. (d) Hydraulic pressures too high or low.	(b) Adjust the throttle linkage. (c) Adjust the kickdown band. (d) Perform the hydraulic pressure tests and adjust to specifications.
	(e) Governor sticking.	(e) Remove and clean the governor. Replace if necessary.
	(f) Valve body malfunction or leakage.	(f) Perform pressure tests to determine cause and correct as required.
	(g) Accumulator sticking, broken rings or spring.	(g) Inspect accumulator for sticking, broken rings or spring. Repair as required.
	(h) Clutches or servos sticking or not operating.	(h) Remove the valve body assembly and perform the air pressure tests. Repair as required.
	(i) Faulty rear oil pump.	(i) Perform the hydraulic pressure test, adjust or repair as required.
	(j) Kickdown servo, band or linkage malfunction.	(j) Inspect the servo for sticking, broken seal rings, binding linkage or faulty band lining. Repair as required.
	(k) Worn or faulty front clutch.	(k) Disassemble and inspect clutch. Repair or replace as required.
	(l) Worn or broken input shaft and/or reaction shaft support seal rings.	(l) Inspect and replace the seal rings as required, also inspect the respective bore for wear. Replace parts as required.
NO KICKDOWN OR NORMAL DOWNSHIFT	(a) Incorrect throttle linkage adjustment. (b) Incorrect control cable adjustment. (c) Kickdown band out of adjustment. (d) Hydraulic pressures too high or low.	(a) Adjust the throttle linkage. (b) Adjust the control cable. (c) Adjust the kickdown band. (d) Perform the hydraulic pressure tests and adjust to specifications.
	(e) Governor sticking.	(e) Remove and clean the governor. Replace parts if necessary.
	(f) Valve body malfunction or leakage.	(f) Perform pressure tests to determine cause and correct as required.
	(g) Accumulator sticking, broken rings or spring.	(g) Inspect the accumulator for sticking, broken rings or spring. Repair as required.
	(h) Clutches or servos sticking or not operating.	(h) Remove the valve body assembly and perform the air pressure tests. Repair as required.
	(i) Kickdown servo, band or linkage malfunction.	(i) Inspect the servo for sticking, broken seal rings, binding linkage or faulty band lining. Repair as required.
	(j) Overrunning clutch not holding.	(j) Disassemble the transmission and repair, the overrunning clutch as required.
SHIFTS ERRATIC	(a) Low fluid level.	(a) Refill to the correct level with Automatic Transmission Fluid, Type "A," Suffix "A."
	(b) Aerated fluid.	(b) Inspect for air leakage into the front pump suction passages.
	(c) Incorrect throttle linkage adjustment.	(c) Adjust the throttle linkage.
	(d) Incorrect control cable adjustment.	(d) Adjust the control cable.
	(e) Hydraulic pressures too high or low.	(e) Perform the hydraulic pressure tests and adjust to specifications.
	(f) Governor sticking.	(f) Remove and clean the governor. Replace parts if necessary.
	(g) Oil filter clogged.	(g) Replace the oil filter.
	(h) Valve body malfunction or leakage.	(h) Perform pressure tests to determine cause and correct as required.

Condition	Possible Cause	Correction
SLIPS IN FORWARD DRIVE POSITIONS	(i) Clutches or servos sticking or not operating.	(i) Remove the valve body assembly and perform air pressure tests. Repair as required.
	(j) Faulty rear and/or front oil pump.	(j) Perform the hydraulic pressure tests, adjust or repair as required.
	(k) Worn or broken input shaft and/or reaction shaft support seal rings.	(k) Inspect and replace the seal rings as required, also inspect respective bores for wear. Replace the parts as required.
	(a) Low fluid level.	(a) Refill to the correct level with Automatic Transmission Fluid, Type "A", Suffix "A."
	(b) Aerated fluid.	(b) Inspect for air leakage into the front pump suction passages.
	(c) Incorrect throttle linkage adjustment.	(c) Adjust the throttle linkage.
	(d) Incorrect control cable adjustment.	(d) Adjust the control cable.
	(e) Hydraulic pressures too low.	(e) Perform the hydraulic pressure tests and adjust to specifications.
	(f) Valve body malfunction or leakage.	(f) Perform pressure tests to determine cause and correct as required.
	(g) Accumulator sticking, broken rings or spring.	(g) Inspect the accumulator for sticking, broken rings or spring. Repair as required.
	(h) Clutches or servos sticking or not operating.	(h) Remove the valve body assembly perform air pressure tests. Repair as required.
	(i) Worn or faulty front and/or rear clutch.	(i) Disassemble and inspect clutch. Repair or replace as required.
	(j) Overrunning clutch not holding.	(j) Disassemble the transmission and repair the overrunning clutch as required.
(k) Worn or broken input shaft and/or reaction shaft support seal rings.	(k) Inspect and replace the seal rings as required, also inspect the respective bores for wear. Replace parts as required.	
SLIPS IN REVERSE ONLY	(a) Low fluid level.	(a) Refill to correct level with Automatic Transmission Fluid, Type "A," Suffix "A."
	(b) Aerated fluid.	(b) Inspect for air leakage into front pump suction passages.
	(c) Incorrect control cable adjustment.	(c) Adjust the control cable.
	(d) Hydraulic pressures too high or low.	(d) Perform the hydraulic pressure tests and adjust to specifications.
	(e) Low-reverse band out of adjustment.	(e) Adjust the low-reverse band.
	(f) Valve body malfunction or leakage.	(f) Perform pressure tests to determine cause and correct as required.
	(g) Front clutch or rear servo, sticking or not operating.	(g) Remove the valve body assembly and perform air pressure tests. Repair as necessary.
	(h) Low-reverse servo, band or linkage malfunction.	(h) Inspect the servo for damaged seals, binding linkage or faulty band lining. Repair as required.
	(i) Faulty front oil pump.	(i) Perform the hydraulic pressure tests, adjust or repair as required.
	SLIPS IN ALL POSITIONS	(a) Low fluid level.
(b) Hydraulic pressures too low.		(b) Perform the hydraulic pressure tests and adjust to specifications.
(c) Valve body malfunction or leakage.		(c) Perform pressure tests to determine cause and correct as required.
(d) Faulty front oil pump.		(d) Perform the hydraulic pressure tests, adjust or repair as required.

	(e) Clutches or servos sticking or not operating.	(e) Remove the valve body assembly and perform air pressure tests. Repair as required.
	(f) Worn or broken input shaft and/or reaction shaft support seal rings.	(f) Inspect and replace the seal rings as required, also inspect respective bores for wear. Replace the parts as required.
NO DRIVE IN ANY POSITION	(a) Low fluid level.	(a) Refill to the correct level with Automatic Transmission Fluid, Type "A," Suffix "A."
	(b) Hydraulic pressures too low.	(b) Perform the hydraulic pressure tests and adjust to specifications.
	(c) Oil filter clogged.	(c) Replace the oil filter.
	(d) Valve body malfunction or leakage.	(d) Perform pressure tests to determine cause and correct as required.
	(e) Faulty front oil pump.	(e) Perform the hydraulic pressure tests, adjust or repair as required.
	(f) Clutches or servos sticking or not operating.	(f) Remove the valve body assembly and perform air pressure tests. Repair as required.
NO DRIVE IN FORWARD DRIVE POSITIONS	(a) Hydraulic pressures too low.	(a) Perform the hydraulic pressure tests and adjust to specifications.
	(b) Valve body malfunction or leakage.	(b) Perform pressure tests to determine cause and correct as required.
	(c) Accumulator sticking, broken rings or spring.	(c) Inspect the accumulator for sticking, broken rings or springs. Repair as required.
	(d) Clutches or servos, sticking or not operating.	(d) Remove the valve body assembly perform air pressure tests. Repair as required.
	(e) Worn or faulty rear clutch.	(e) Disassemble and inspect clutch. Repair or replace as required.
	(f) Overrunning clutch not holding.	(f) Disassemble the transmission and repair over-running clutch as required.
	(g) Worn or broken input shaft and/or reaction shaft support seal rings.	(g) Inspect and replace the seal rings as required, also inspect the respective bores for wear. Replace parts as required.
NO DRIVE IN REVERSE	(a) Incorrect control cable adjustment.	(a) Adjust the control cable.
	(b) Hydraulic pressures too low.	(b) Perform the hydraulic pressure tests and adjust to specifications.
	(c) Low-reverse band out of adjustment.	(c) Adjust the low-reverse band.
	(d) Valve body malfunction or leakage.	(d) Perform pressure tests to determine cause and correct as required.
	(e) Front clutch or rear servo, sticking or not operating.	(e) Remove the valve body assembly and perform air pressure tests. Repair as required.
	(f) Low-reverse servo, band or linkage malfunction.	(f) Inspect the servo for damaged seals, binding linkage or faulty band lining. Repair as required.
	(g) Worn or faulty front clutch.	(g) Disassemble and inspect clutch. Repair or replace as required.
DRIVES IN NEUTRAL	(a) Incorrect control cable adjustment.	(a) Adjust the control cable.
	(b) Valve body malfunction or leakage.	(b) Perform pressure tests to determine cause and correct as required.
	(c) Rear clutch inoperative.	(c) Inspect the clutch and repair as required.
DRAGS OR LOCKS	(a) Kickdown band out of adjustment.	(a) Adjust the kickdown band.
	(b) Low-reverse band out of adjustment.	(b) Adjust the low-reverse band.

Condition	Possible Cause	Correction
	(c) Kickdown and/or low-reverse servo, band, linkage malfunction.	(c) Inspect the servo for sticking, broken seal rings, binding linkage or faulty band lining. Repair as required.
	(d) Front and/or rear clutch faulty.	(d) Disassemble and inspect clutch. Repair or replace as required.
	(e) Planetary gear sets broken or seized.	(e) Inspect the condition of the planetary gear sets and replace as required.
	(f) Overrunning clutch worn, broken or seized.	(f) Inspect the condition of the overrunning clutch and replace parts as required.
GRATING, SCRAPING OR GROWLING NOISE	(a) Kickdown band out of adjustment.	(a) Adjust the kickdown band.
	(b) Low-reverse band out of adjustment.	(b) Adjust the low-reverse band.
	(c) Output shaft bearing or bushing damaged.	(c) Remove the extension housing and replace the bearing or bushing.
	(d) Governor support binding or broken seal rings.	(d) Inspect the condition of the governor support and repair as required.
	(e) Front and/or rear oil pump scored or binding.	(e) Inspect the condition of the pump and repair as required.
	(f) Front and/or rear clutch faulty.	(f) Disassemble and inspect clutch. Repair or replace as required.
	(g) Planetary gear sets broken or seized.	(g) Inspect the condition of the planetary gear sets and replace as required.
	(h) Overrunning clutch worn, broken or seized.	(h) Inspect the condition of overrunning clutch and replace parts as required.
BUZZING NOISE	(a) Low fluid level.	(a) Refill to the correct level with Automatic Transmission Fluid, Type "A," Suffix "A."
	(b) Pumps sucking air.	(b) Inspect the pumps for nicks or burrs on mating surfaces, porous casting, and/or excessive rotor clearance. Replace the parts as required.
	(c) Valve body malfunction.	(c) Remove and recondition the valve body assembly.
	(d) Overrunning clutch inner race damaged.	(d) Inspect and repair the clutch as required.
HARD TO FILL, OIL FLOWS OUT FILLER TUBE	(a) High fluid level.	(a) Drain the fluid to the correct level.
	(b) Breather clogged.	(b) Inspect and clean breather vent opening in front pump housing.
	(c) Oil filter clogged.	(c) Replace the oil filter.
	(d) Aerated fluid.	(d) Inspect for air leakage into front pump suction passages.
TRANSMISSION OVERHEATS	(a) Low fluid level.	(a) Refill to the correct level with Automatic Transmission Fluid, Type "A," Suffix "A."
	(b) Kickdown band adjustment too tight.	(b) Adjust the kickdown band.
	(c) Low-reverse band adjustment too tight.	(c) Adjust the low-reverse band.
	(d) Faulty cooling system.	(d) Inspect the transmission cooling system, clean and repair as required.
	(e) Cracked or restricted oil cooler line or fitting.	(e) Inspect, repair or replace as required.
	(f) Faulty rear and/or front oil pump.	(f) Inspect the oil pump for incorrect clearance, repair as required.
	(g) Insufficient clutch plate clearance in front and/or rear clutches.	(g) Measure the clutch plate clearance and correct with the proper size snap ring.
IMPOSSIBLE TO PUSH START	(a) Low fluid level.	(a) Refill to the correct level with Automatic Transmission Fluid, Type "A," Suffix "A."
	(b) Low-reverse band slipping.	(b) Adjust the low-reverse band.

- (c) Valve body malfunction or leakage.
- (d) Rear oil pump faulty.
- (e) Low-reverse servo, band or linkage malfunction.
- (f) Worn or faulty rear clutch.
- (g) Worn or broken input shaft and/or reaction shaft support seal rings.
- (c) Remove and recondition the valve body assembly.
- (d) Inspect and repair the rear oil pump as required.
- (e) Inspect the servo for damaged seals, binding linkage or faulty band lining. Repair as required.
- (f) Disassemble and inspect clutch. Repair or replace as required.
- (g) Inspect and replace the seal rings as required, also inspect respective bores for wear. Replace the parts as required.

STARTER WILL NOT ENERGIZE IN NEUTRAL

- (a) Incorrect control cable adjustment.
- (b) Faulty or incorrectly adjusted neutral starting switch.
- (c) Broken lead to neutral switch.
- (a) Adjust the control cable.
- (b) Test the operation of the switch with a test lamp. Adjust or replace as required.
- (c) Inspect the lead and test with a test lamp. Repair the broken lead.

CLUTCH ENGAGEMENT AND BAND APPLICATION CHART

LEVER POSITION AND DRIVE CONDITION	FRONT CLUTCH	REAR CLUTCH	FRONT (KICKDOWN) BAND	REAR (LOW-REV.) BAND	OVERRUNNING CLUTCH
N NEUTRAL	DISENGAGED	DISENGAGED	RELEASED	RELEASED	NO MOVEMENT
D—DRIVE (DIRECT) 1.00 to 1	ENGAGED	ENGAGED	RELEASED	RELEASED	OVER RUNS
D—DRIVE (BREAKAWAY) 2.45 to 1	DISENGAGED	ENGAGED	RELEASED	RELEASED	HOLDS
D—DRIVE KICKDOWN (TO SECOND) 1.45 to 1	DISENGAGED	ENGAGED	APPLIED	RELEASED	OVER RUNS
2—SECOND 1.45 to 1	DISENGAGED	ENGAGED	APPLIED	RELEASED	OVER RUNS
2—SECOND KICKDOWN (TO LOW) 2.45 to 1	DISENGAGED	ENGAGED	RELEASED	RELEASED	HOLDS
1—LOW 2.45 to 1	DISENGAGED	ENGAGED	RELEASED	APPLIED	PARTIAL HOLD
1—LOW (RETARDING) 2.45 to 1	DISENGAGED	ENGAGED	RELEASED	APPLIED	NO MOVEMENT
R—REVERSE 2.20 to 1	ENGAGED	DISENGAGED	RELEASED	APPLIED	NO MOVEMENT

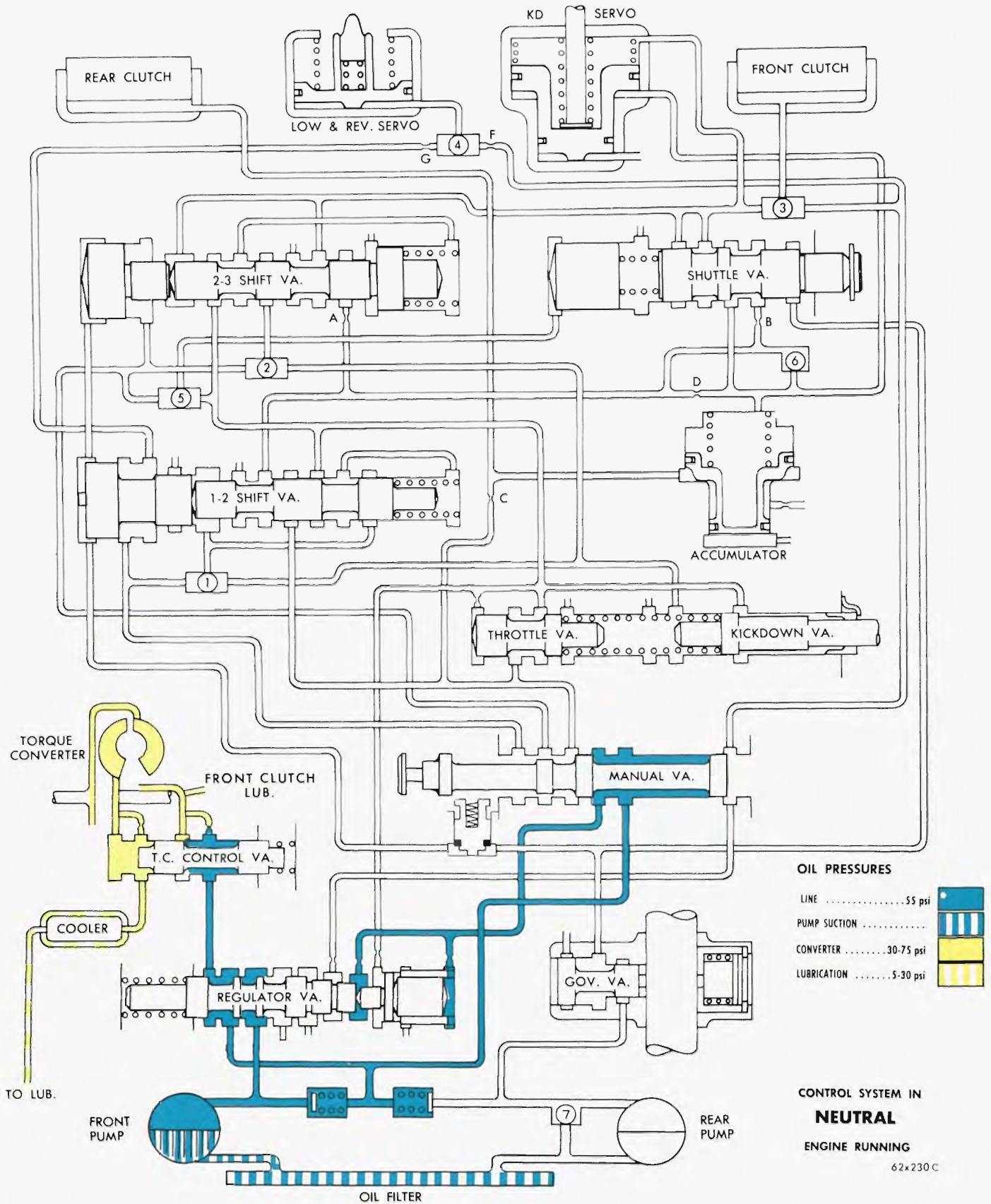

OIL PRESSURES

- LINE 55 psi
- PUMP SUCTION
- CONVERTER 30-75 psi
- LUBRICATION 5-30 psi



CONTROL SYSTEM IN

NEUTRAL

ENGINE RUNNING

62x230 C

Neutral Hydraulic Circuits

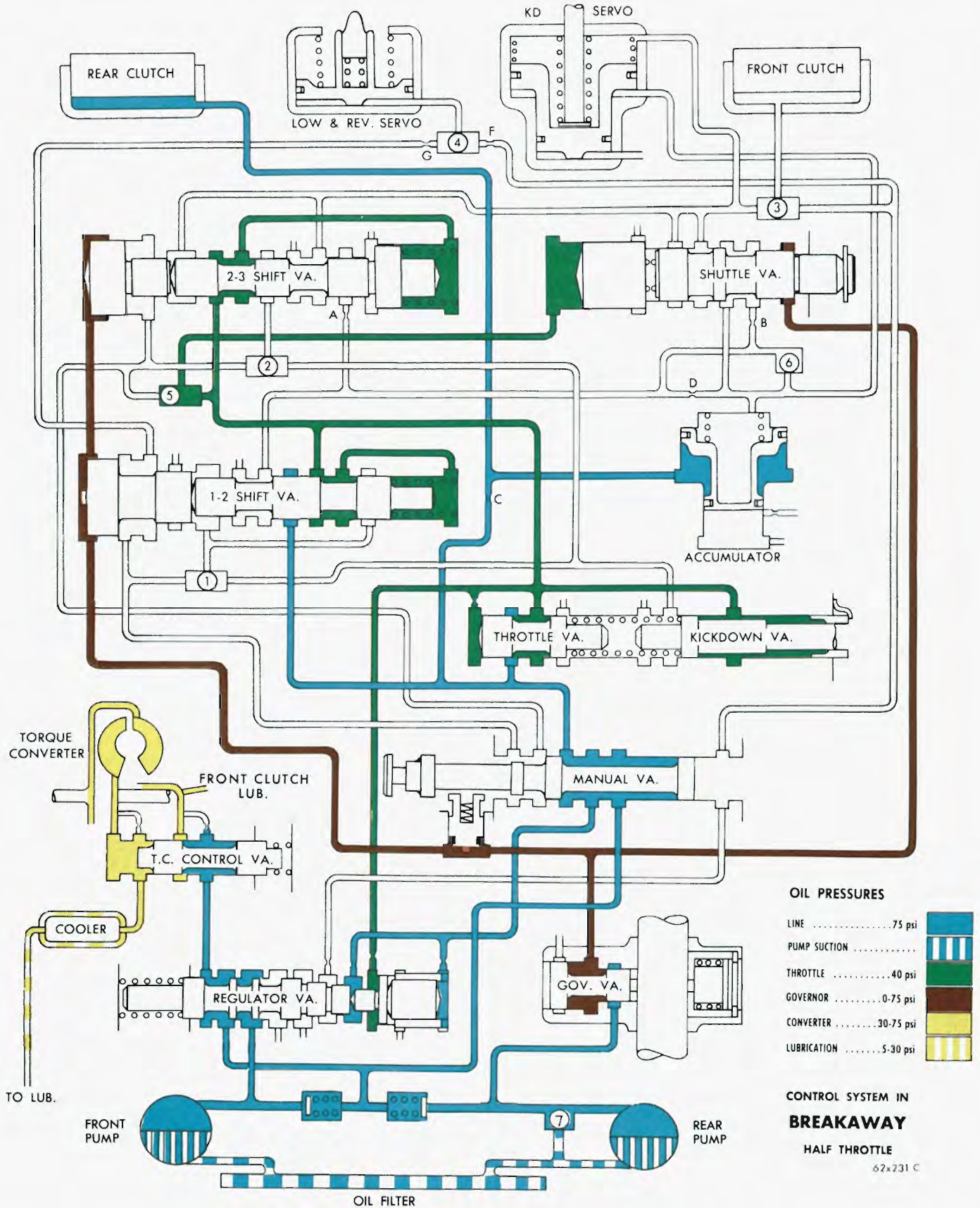

OIL PRESSURES

LINE 75 psi	
PUMP SUCTION	
THROTTLE 40 psi	
GOVERNOR 0-75 psi	
CONVERTER 30-75 psi	
LUBRICATION 5-30 psi	

CONTROL SYSTEM IN BREAKAWAY

HALF THROTTLE
62x231 C

Drive-Breakaway Hydraulic Circuits

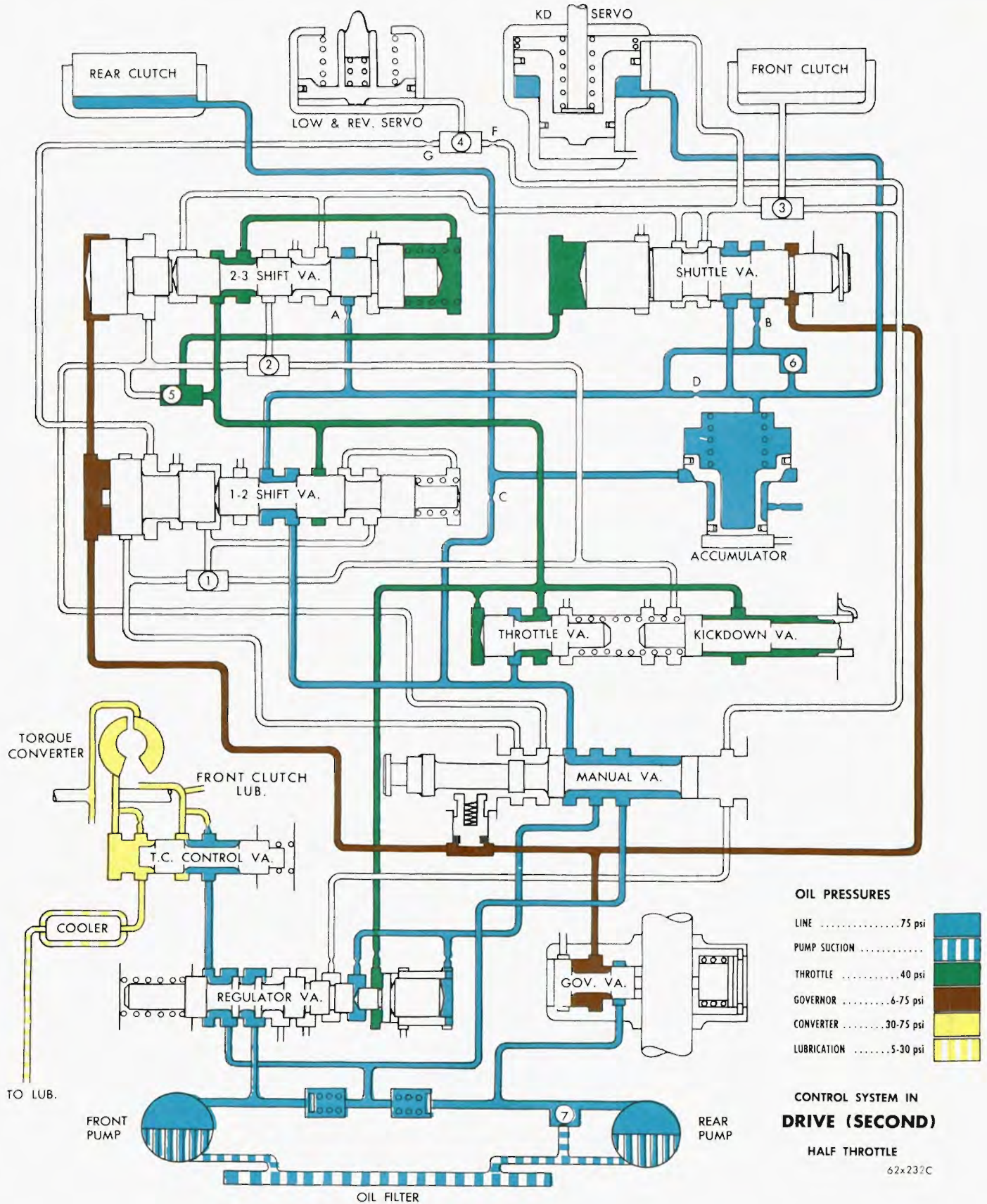

Drive-Second Hydraulic Circuits

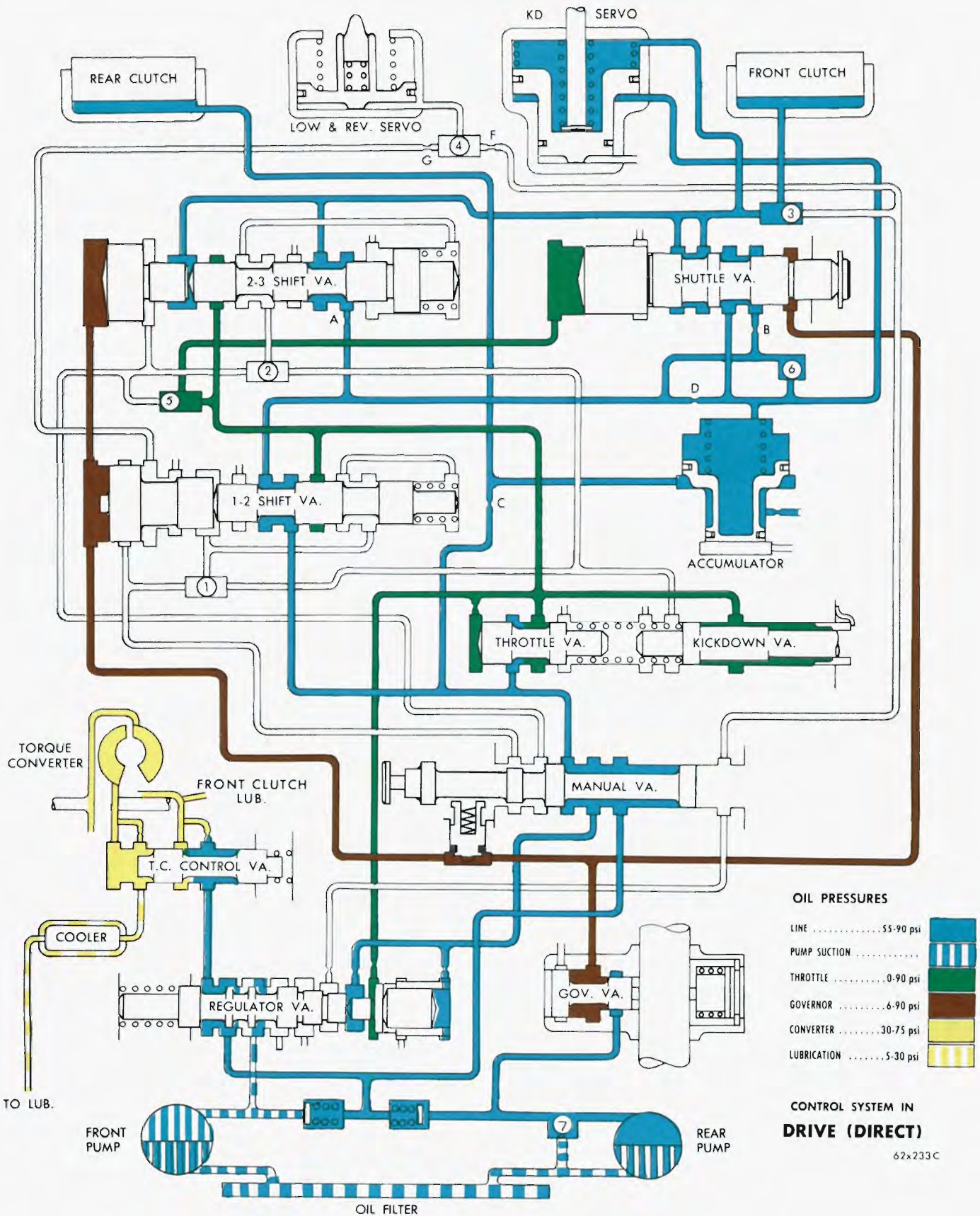

OIL PRESSURES

LINE 55-90 psi	
PUMP SUCTION	
THROTTLE 0-90 psi	
GOVERNOR 6-90 psi	
CONVERTER 30-75 psi	
LUBRICATION 5-30 psi	

CONTROL SYSTEM IN DRIVE (DIRECT)

62x233C

Drive-Direct Hydraulic Circuits

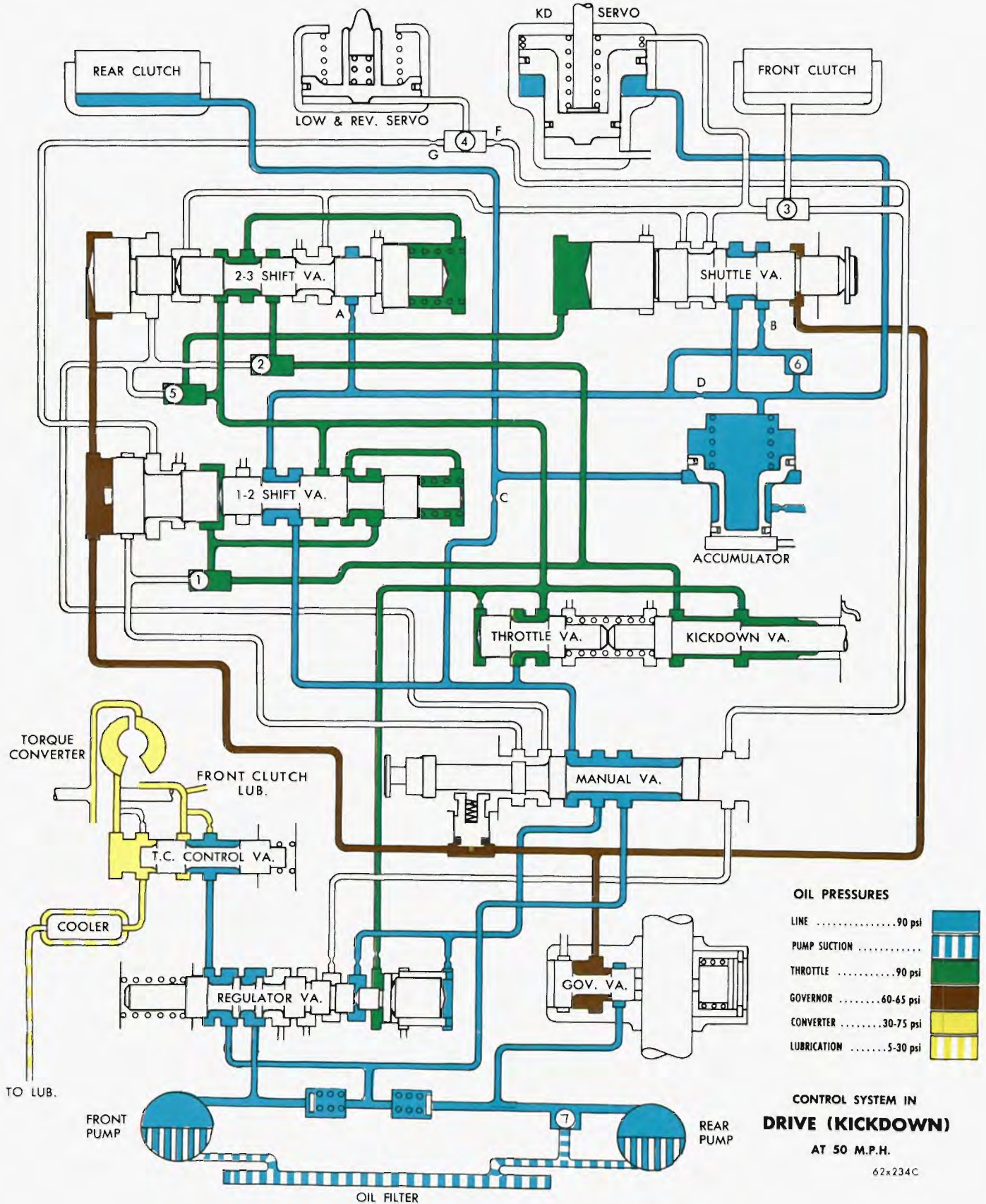

OIL PRESSURES

LINE 90 psi	
PUMP SUCTION	
THROTTLE 90 psi	
GOVERNOR 60-65 psi	
CONVERTER 30-75 psi	
LUBRICATION 5-30 psi	

CONTROL SYSTEM IN DRIVE (KICKDOWN) AT 50 M.P.H.
62x234C

Drive-Kickdown Hydraulic Circuits

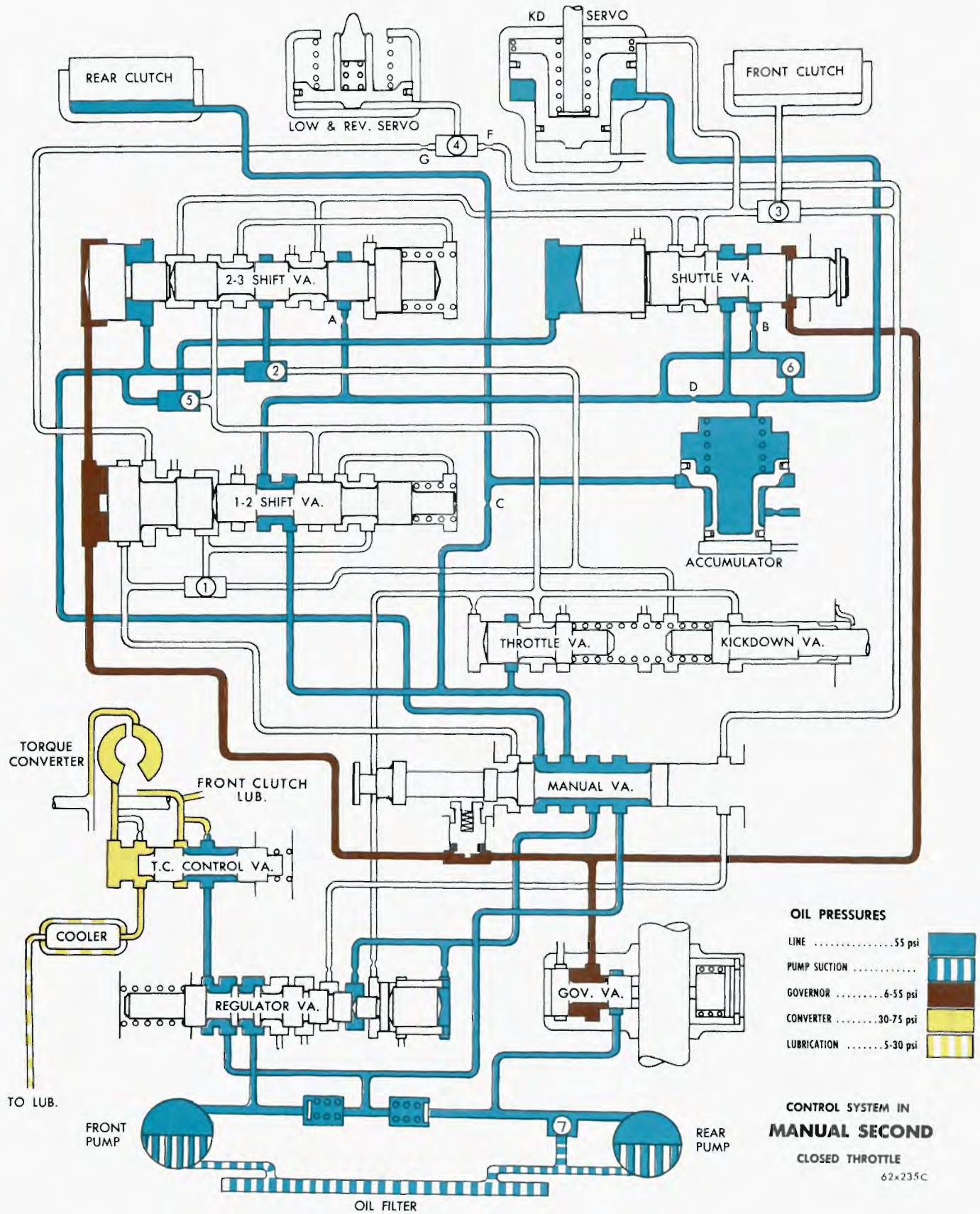

OIL PRESSURES

LINE 55 psi	
PUMP SUCTION	
GOVERNOR 6-55 psi	
CONVERTER 30-75 psi	
LUBRICATION 5-30 psi	

**CONTROL SYSTEM IN
MANUAL SECOND**
CLOSED THROTTLE
62x235C

Selector Lever Second-Hydraulic Circuits

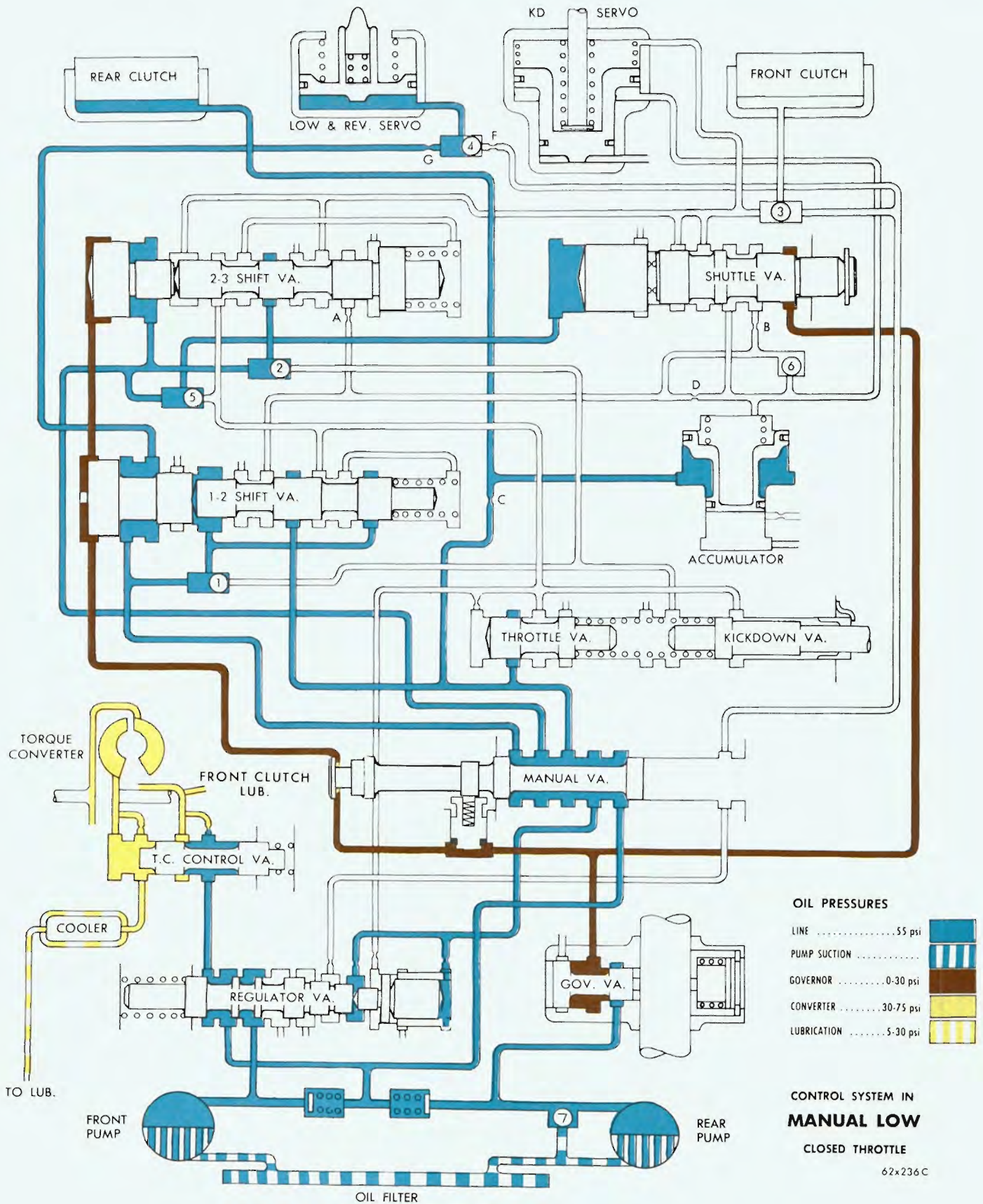

Selector Lever Low-Hydraulic Circuits

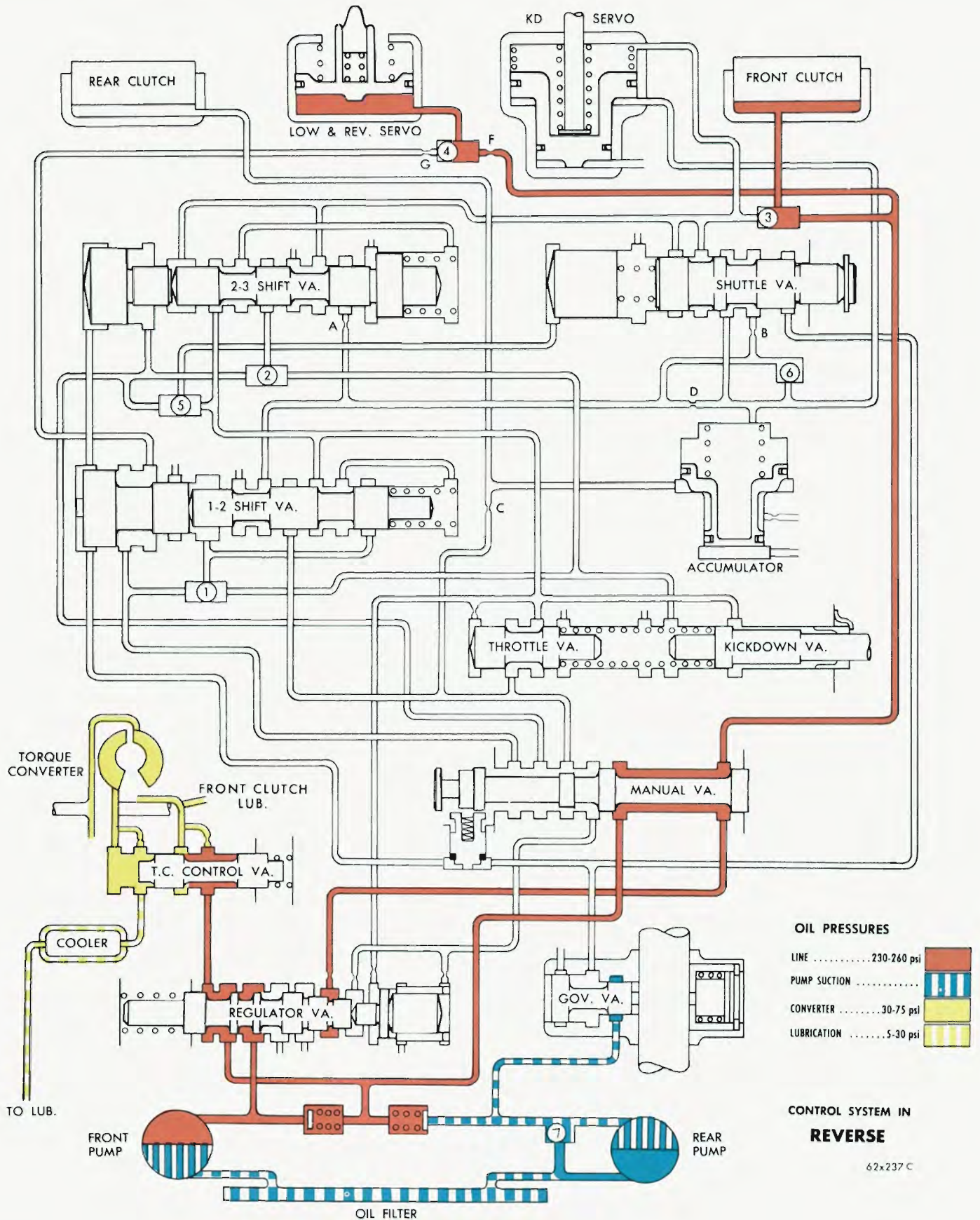

Reverse Hydraulic Circuits

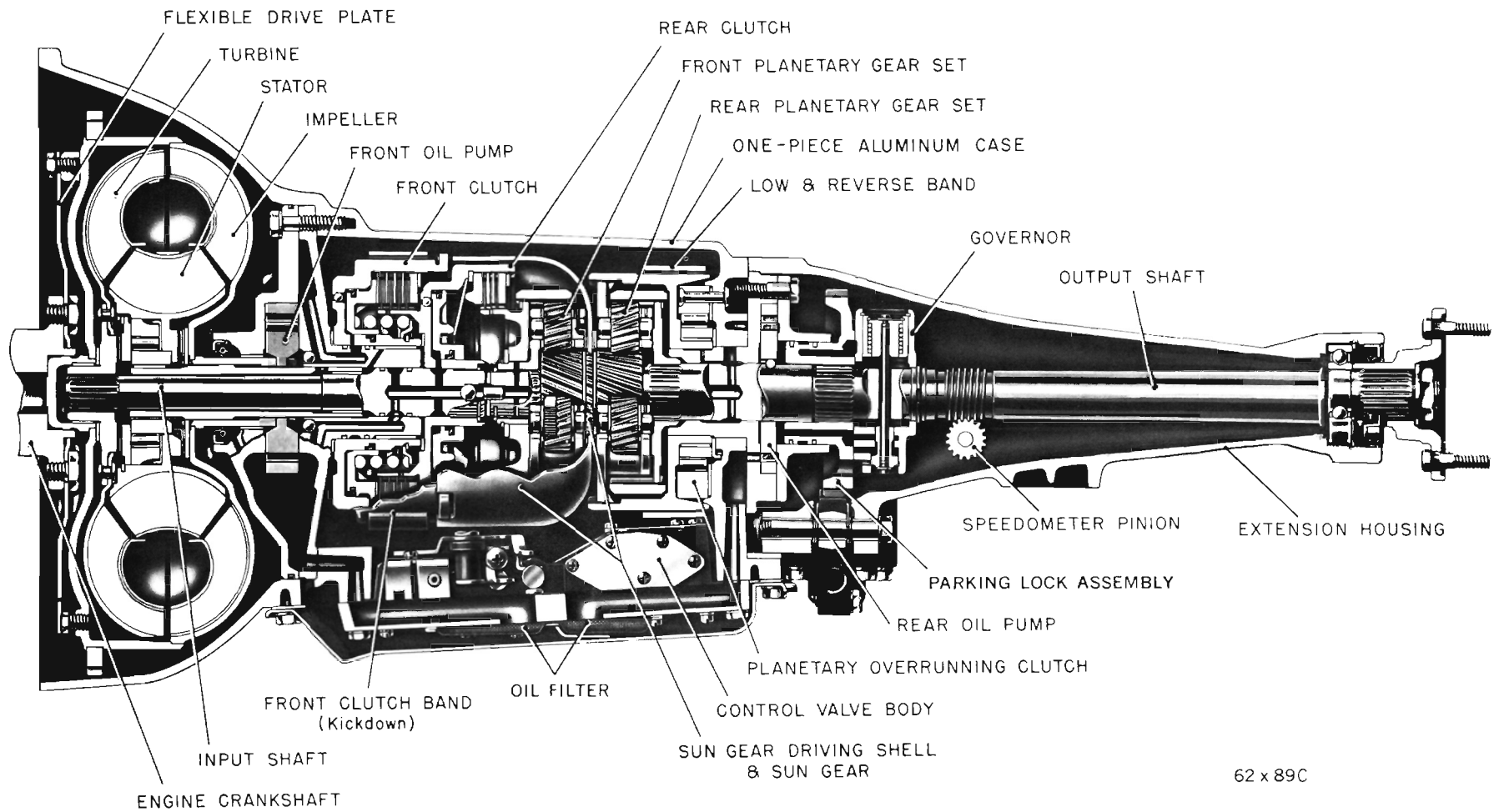

Fig. 1—TorqueFlite Transmission and Torque Converter (A-904-G and A-904-LA)

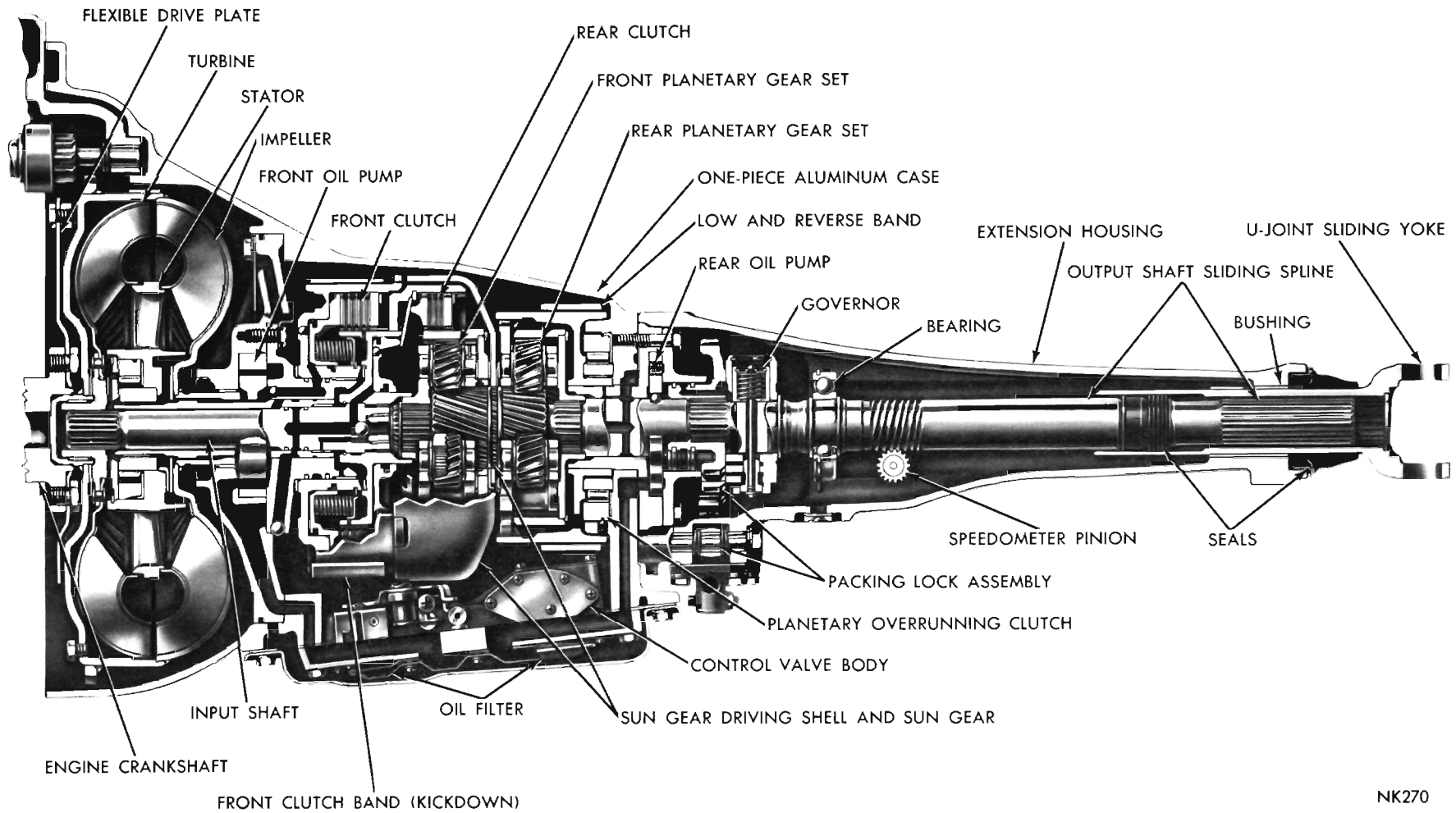

Fig. 2—TorqueFlite Transmission and Torque Converter (A-727-A and B)

HYDRAULIC CONTROL SYSTEM

The hydraulic control circuits on pages 37 through 44 show the position of the various valves with color coded passages to indicate those under hydraulic pressure for all operations of the transmission.

The hydraulic control system makes the transmission fully automatic, and has four important functions to perform. In a general way, the components of any automatic control system may be grouped into the following basic groups:

The pressure supply system, the clutches and band servos, the pressure regulating valves and the flow control valves.

Taking each of these basic groups or systems in turn, the control system may be described as follows:

Pressure Supply System

The pressure supply system consists of a front pump driven by the engine through the torque converter, and a rear pump driven by the transmission output shaft.

Pressure Regulating Valves

The pressure regulating valves consist of a regulator valve which controls line pressure at a value dependent on throttle opening.

The torque converter control valve maintains torque converter operating pressure and transmission lubricating pressure.

The governor valve transmits regulated pressure to the transmission (in conjunction with throttle pressure) to control upshift and downshift speeds.

The throttle valve transmits regulated pressure to the transmission (in conjunction with governor pressure) to control upshift and downshift speeds.

Flow Control Valves

The rear pump check valve prevents loss of front pump pressure through the rear pump circuit during reverse operation. The front pump check valve prevents loss of rear pump pressure through the front pump circuit when the front pump flow is recirculating.

A check valve is incorporated in the rear oil pump cover to prevent air from entering the system during reverse operation.

The manual valve obtains the different transmission drive ranges as selected by the vehicle operator.

The reverse blocker valve mechanically blocks the manual valve from moving into reverse position above approximately 20 mph.

The 1-2 shift valve automatically shifts the transmission from low to second or from second to low depending on the vehicle operation.

The 2-3 shift valve automatically shifts the transmission from second to direct or from direct to second depending on the vehicle operation.

The kickdown valve makes possible a forced downshift from direct to second-second to breakaway or direct to breakaway (depending on vehicle speed)by depressing the accelerator pedal past the detent "feel" near wide open throttle.

The shuttle valve has two separate functions and performs each independently of each other. The first is that of providing fast release of the kickdown band, and smooth front clutch engagement when the driver makes a "lift-foot" upshift from second to direct. The second function of the shuttle valve is to regulate the application of the kickdown servo and band when making direct to second kickdowns.

Clutches, Band Servos and Accumulator

The front and rear clutch pistons, and both servo pistons are moved hydraulically to engage the clutches and apply the bands. The pistons are released by spring tension when hydraulic pressure is released. On the 2-3 upshift, the kickdown servo piston is released by spring tension and hydraulic pressure.

The accumulator controls the hydraulic pressure on the apply side of the kickdown servo during the 1-2 shift; thereby, cushioning the kickdown band application at any throttle position.

GEARSHIFT AND PARKING LOCK CONTROLS

The transmission is controlled by a "lever type" gearshift incorporated within the steering column. The control has six selector lever positions: P (park), R (reverse), N (neutral), D (drive), 2 (second) and 1 (low). Some vehicles are equipped with a "lever type" console gearshift which has the same selector lever positions.

Mechanical connection between the gearshift control and the transmission manual control valve, and the parking lock is obtained through two cables enclosed in weatherproof housings. The parking lock is applied by moving the selector lever past a gate to the P position.

CAUTION: Never apply the parking lock until the vehicle has stopped; otherwise, a severe ratcheting noise will occur.

OPERATING INSTRUCTIONS

The transmission will automatically upshift and downshift at approximately the speeds shown, in the "Shift Pattern Summary Chart."

NOTE: All shift speeds given in the "Shift Pattern

SHIFT PATTERN SUMMARY CHART

(Six Cylinder Vehicles)

		VEHICLE SPEED TO AXLE RATIOS					
		AV1 6.50-13		AR1 7.35-14		AP1 7.35-14	
Condition		3.23:1	3.55:1	2.93:1	3.55:1	2.93:1	3.23:1
Closed Throttle	1-2 Upshift	6-11	5-10	6-12	5-10	6-12	6-11
Closed Throttle	2-3 Upshift	11-15	10-14	11-16	9-13	11-16	10-15
Wide Open Throttle	1-2 Upshift	26-41	23-37	29-41	24-34	29-41	26-37
Wide Open Throttle	2-3 Upshift	57-69	53-64	61-74	50-61	61-74	55-67
3-2 Kickdown Limit		50-62	46-57	52-66	43-55	52-66	47-60
3-1 Kickdown Limit		25-36	22-33	28-36	23-30	28-36	25-33
Closed Throttle	Downshift	4-10	4-9	5-11	4-9	5-11	4-10

SHIFT PATTERN SUMMARY CHART

(Eight Cylinder Vehicles)

		VEHICLE SPEED TO AXLE RATIOS						426 Cu. In. Eng. 7.75-14
		AV2 7.00-13		AR2 7.35-14		AP2 7.75-14		7.75-14
Condition		2.93:1	3.23:1	2.93:1	3.23:1	2.93:1	3.23:1	3.23:1
Closed Throttle	1-2 Upshift	6-12	6-11	6-12	6-11	7-13	6-12	6-12
Closed Throttle	2-3 Upshift	12-17	11-15	11-16	10-15	12-17	11-16	11-16
Wide Open Throttle	1-2 Upshift	28-46	26-42	29-41	26-37	29-41	26-37	32-47
Wide Open Throttle	2-3 Upshift	64-78	58-70	61-74	55-67	63-75	57-68	66-76
3-2 Kickdown Limit		56-70	51-63	52-66	47-60	54-66	49-60	58-69
3-1 Kickdown Limit		27-41	25-37	28-36	25-33	28-36	25-33	25-43
Closed Throttle	Downshift	5-11	4-10	5-11	4-10	5-12	4-11	4-11

Summary Chart" may vary somewhat due to production tolerances and rear axle ratios. This is not too important; however, the quality of the shifts is very important. All shifts should be smooth, responsive, and with no noticeable engine runaway.

Starting the Engine

The engine will start with the selector lever in either the P (park) or N (neutral) positions.

- (1) As a safety precaution when starting in the N (neutral) position, apply the parking or foot brake.
- (2) Depress the accelerator pedal one-third of travel to insure proper choke operation.
- (3) Turn the ignition key all the way to the right to START position. When the engine starts, release the key and it will return to the ON position.

Push Starting

If the engine fails to start in the normal manner, it

may be started by pushing. Towing the vehicle to start is not recommended due to the sudden surge of power when the engine starts.

Turn the ignition on, then move the selector lever to the low position and depress the accelerator pedal slightly. After the vehicle has been pushed to a speed of 15 to 25 mph, the transmission will drive the engine.

Mountain Driving

When driving in the mountains with either heavy loads or when pulling trailers, the 2 (second) or 1 (low) position should be selected on upgrades which require heavy throttle for 1/2 mile or more. Lower ratios reduce possibility of overheating the transmission and converter under these conditions. 1 (low) position is for severe operation or to obtain better control.

HELI-COIL CHART

HELI-COIL INSERT			DRILL	TAP	INSERTING TOOL	EXTRACTING TOOL
Thread Size	Part No.	Insert Length	Size	Part No.	Part No.	Part No.
10-24	1185-3	.285"	13/64" (.203")	3 CPB	528-3N	1227-6
¼-20	1185-4	⅜"	17/64" (.265")	4 CPB	528-4N	1227-6
5/16-18	1185-5	15/32"	Q (.332")	5 CPB	528-5N	1227-6
⅜-16	1185-6	9/16"	X (.397")	6 CPB	528-6N	1227-6
7/16-14	1185-7	21/32"	29/32" (.453")	7 CPB	528-7N	1227-16

Towing Vehicle

Transmission Inoperative: Tow the vehicle with a rear end pickup or remove the propeller shaft.

Transmission Operating Properly: The vehicle may be towed safely in N (neutral) at moderate speeds. For long distance towing (over 100 miles), the propeller shaft should be removed.

ALUMINUM THREAD REPAIR

Damaged or worn threads in the aluminum transmission case and valve body can be repaired by the use of Heli-Coils. Essentially, this repair consists of drilling out the worn or damaged threads, tapping the

hole with a special Heli-Coil Tap, and installing a Heli-Coil insert into the tapped hole. This brings the hole back to its original thread size.

The chart lists the threaded hole sizes which are used in the aluminum case and valve body, and the necessary tools and inserts for the repair of damaged or worn threads. Heli-Coil tools and inserts are readily available from most automotive parts jobbers.

NOTE: Some thread drag may occur in screwing a bolt into the installed Heli-Coil insert. Therefore, a torque reading should be taken of the thread drag with an inch-pound torque wrench and added to the specified bolt torque, so that all bolts securing a particular part will be tightened to the same torque.

SERVICE PROCEDURES

TORQUEFLITE A-904-G, A-904-LA, A-727-A AND B

Various transmission components can be removed for repairs without removing the transmission from the vehicle. The removal, reconditioning and installation procedures for these components are covered here, except the valve body reconditioning, which is described on Page

NOTE: The A-727-A and B transmission has the sliding spline type output shaft. Whenever the propeller shaft front sliding yoke is removed from the transmission, it should be cleaned and relubricated as outlined in Group "O" of this Manual.

Heli-Coil inserts are recommended for repairing damaged, stripped or worn threads in the aluminum parts. Refer to Page 49.

LUBRICATION

The transmission fluid and the oil filter should provide satisfactory lubrication and protection to the automatic transmission and no change is recommended in vehicles used in normal service. Regularly scheduled oil and filter changes, therefore will not be

required in these vehicles, except when the operation of the vehicle is classified as severe.

If the regular operation of the vehicle is classified as severe, the transmission should be adjusted and the fluid and the oil filter changed approximately every 32,000 miles, according to any of the following:

- Police or taxicab operation
- Frequent towing of trailers
- Continuous operation at higher than normal loading and/or temperature.

The transmission should not be idled in gear for long periods.

Fluid Level

Inspect the fluid level every 6 months (more often if conditions warrant) with the engine and transmission at normal operating temperature. Refer to "Lubrication and Maintenance," Group 0.

Drain and Refill

(1) Raise the vehicle on a hoist. Place a drain container with a large opening, under the transmission oil pan.



Fig. 3—Converter Drain Plug

(2) Loosen the pan bolts at one corner, tap the pan to break it loose allowing the fluid to drain, then remove the oil pan.

(3) Remove the access plate from in front of the converter, remove the drain plug allowing the fluid to drain (Fig. 3). Install and tighten the converter drain plug to 14 inch-pounds torque, and install the access plate.

(4) If necessary, adjust the reverse band (Refer to Page 59).

(5) Install a new oil filter on the bottom of the valve body. Be sure to use a new gasket and tighten the filter retaining screws to 28 inch-pounds torque.

(6) Clean the oil pan, and reinstall using a new gasket. Tighten the oil pan bolts to 150 inch-pounds torque.

(7) **A-904-G and A-904-LA:** Pour five quarts of Automatic Transmission Fluid Type "A" Suffix "A" through the filler tube.

A-727-A and B: Pour eight quarts of Automatic Transmission Fluid "A" Suffix "A" through the filler tube.

(8) Start the engine and allow to idle for at least two minutes. Then, with the parking brake on, move the selector lever momentarily to each position, ending in the **neutral** position.

(9) Add sufficient fluid to bring the fluid level to the **"ADD ONE PINT"** mark.

Recheck the fluid level after the transmission is at normal operating temperature. The level should be between the **"FULL"** mark and the **"ADD ONE PINT"** mark (Fig. 4).

CAUTION: To prevent dirt from entering the transmission, make certain that the dip stick cap is fully seated onto the filler tube.

Periodic Adjustments

The following adjustments should be performed at 32,000 mile intervals or more frequent under abnormal operating conditions.

(1) Adjust the kickdown band. Refer to Page 59.

(2) Adjust the gearshift control cable (Refer to Page 57).

(3) Adjust the engine idle in neutral. Refer to the "Fuel System," Group 14.

(4) Adjust the transmission and carburetor throttle linkage to obtain the proper shift pattern (Refer to Page 59).

STEERING COLUMN AND GEARSHIFT

Removal

(1) Disconnect the negative (ground) cable from the battery.

(2) Disconnect the gearshift control cable and parking lock cable from the transmission. Refer to Pages 57 and 58.

(3) Remove the steering shaft coupling to worm shaft lock bolt.

AP-1 and AP-2 Models: Remove the heat shield from the lower end of the steering column.

(4) Disconnect the turn signal, gearshift indicator light and horn wires.

(5) **AV-1 and AV-2 Models:** Remove horn button by inserting a small screw driver into steering wheel slot at edge of the horn button. Pry the horn button and retaining "O" ring out of the steering wheel.

AP-1, AP-2, AR-1 and AR-2 Models: Turn the horn button ¼ turn counter-clockwise and lift it out of the steering wheel. To remove the Deluxe horn ring ornament, remove two screws from the underside of the steering wheel.

(6) Disconnect the horn wire at the horn switch. Remove three screws and insulators, then remove the horn ring and switch.

(7) Remove the steering wheel retaining nut and washer. Remove the steering wheel, using Puller C-3428A. Remove the turn signal lever.

(8) Remove the floor plate to floor pan attaching screws. Remove finish plate from under the instrument panel to expose the steering column bracket



62x167

Fig. 4—Dip Stick Markings

and clamp.

CAUTION: On the AP-1 and AP-2 models, be sure to disconnect the gearshift indicator link before removing the steering column to instrument panel clamp.

(9) **AR-1, AR-2, AV-1 and AV-2 Models:** Remove the steering column to instrument panel retaining clamp and screws.

AP-1 and AP-2 Models: Remove the screw that attaches the gearshift indicator link (slotted end) to the operating lever on the column. Remove the steering column to instrument panel retaining clamp and screws.

(10) On some models, disconnect the brake pedal from the master cylinder so the pedal can be raised to provide steering column removal clearance. Lift the steering column up and off the end of the worm shaft.

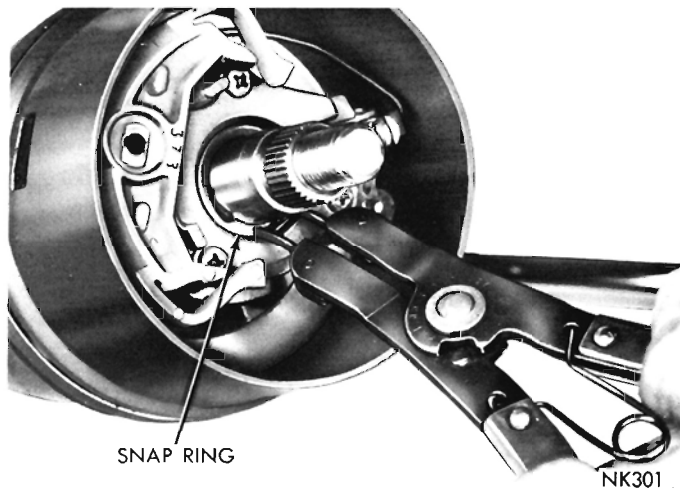

Fig. 5—Removing or Installing Steering Shaft Snap Ring

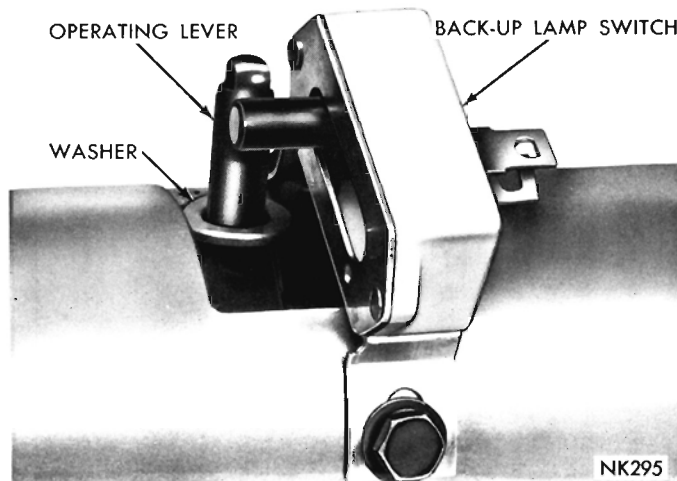

Fig. 6—Back-Up Lamp Switch and Operating Lever (AR-1, AR-2, AV-1, AV-2 Models)

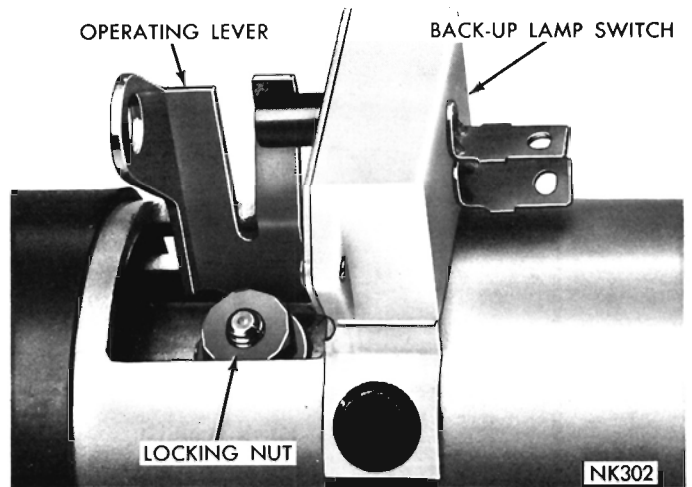

Fig. 7—Back-Up Lamp Switch and Operating Lever (AP-1, AP-2 Models)

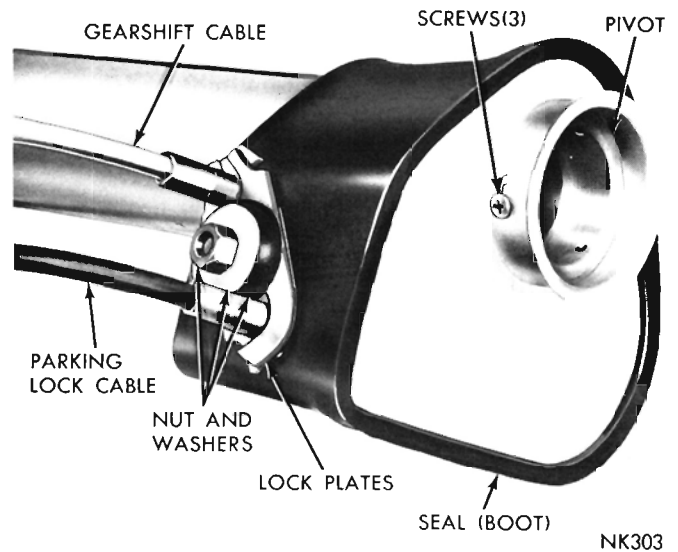

Fig. 8—Removing or Installing Steering Column Lower Plate

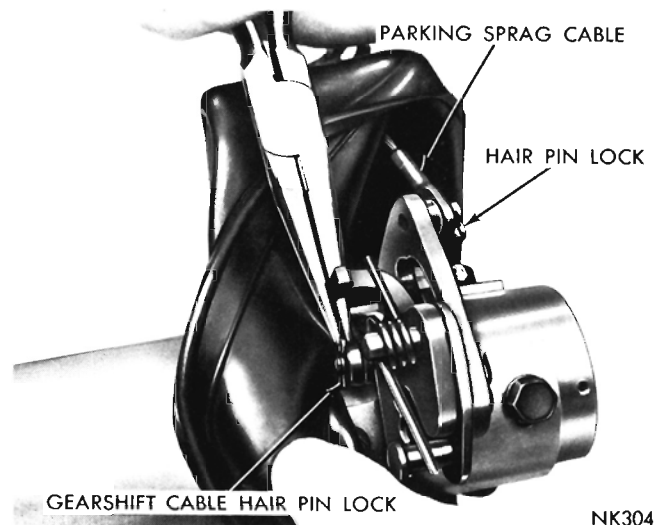

Fig. 9—Removing or Installing Cable Hair Pin Locks

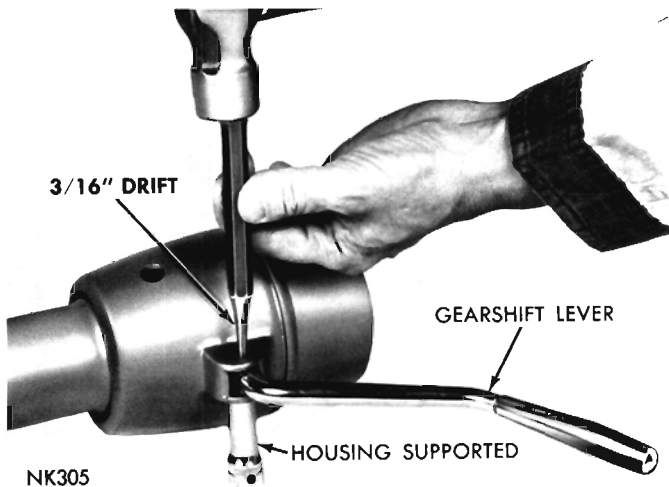

Fig. 10—Removing or Installing Gearshift Lever

CAUTION: As the column assembly is removed up through the opening, be very careful not to kink the cables or damage the back-up light switch.

Disassembly

(1) Remove the snap ring from upper end of the steering shaft (Fig. 5).

(2) Tap the steering shaft downward through the upper column bearing, then remove the shaft and lower bearing from the column.

(3) **AR-1, AR-2, AV-1, AV-2 Models:** Remove the back-up lamp switch (Fig. 6). Lift the washer off the switch operating lever, then unsnap the lever from the gearshift tube.

AP-1, AP-2 Models: Remove the back-up lamp switch (Fig. 7). Loosen the locking nut on the operating lever, then slide the lever out of the groove on the gear-

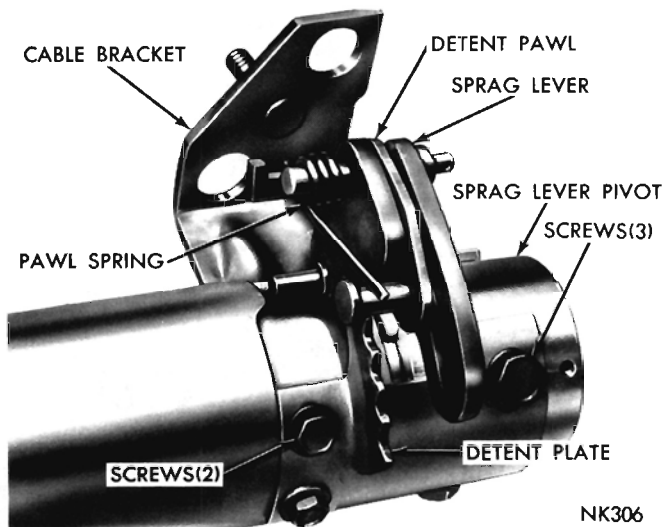

Fig. 11—Lower End of Column—Assembled View

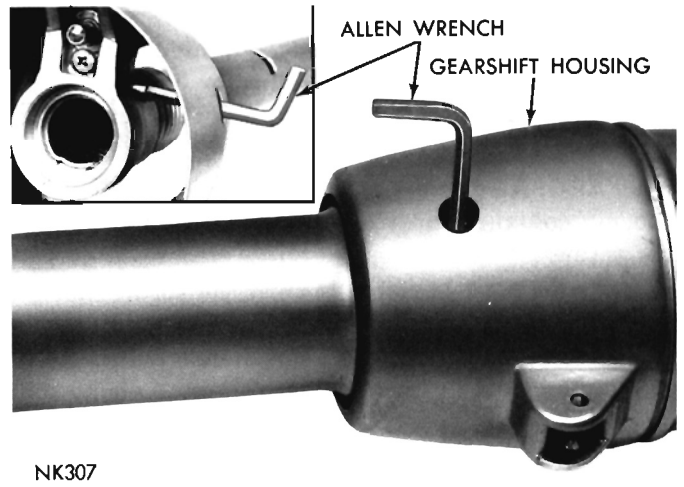

Fig. 12—Removing or Installing Tapered Lock Bolt

shift tube.

(4) Remove plate and seal washer from the sprag lever pivot at lower end of the column (Fig. 8). Remove the cable lock plate retaining nut and washers.

(5) Place the gearshift lever in the “low” position, carefully work the seal (boot) upward and remove the hair pin locks securing cables to their operating levers (Fig. 9). Remove the cable assemblies, then slide the seal upward on the column jacket.

(6) Support the gearshift housing on a small socket, drive out the roll pin and remove the gearshift lever (Fig. 10).

(7) Remove the pawl spring (Fig. 11). Remove three

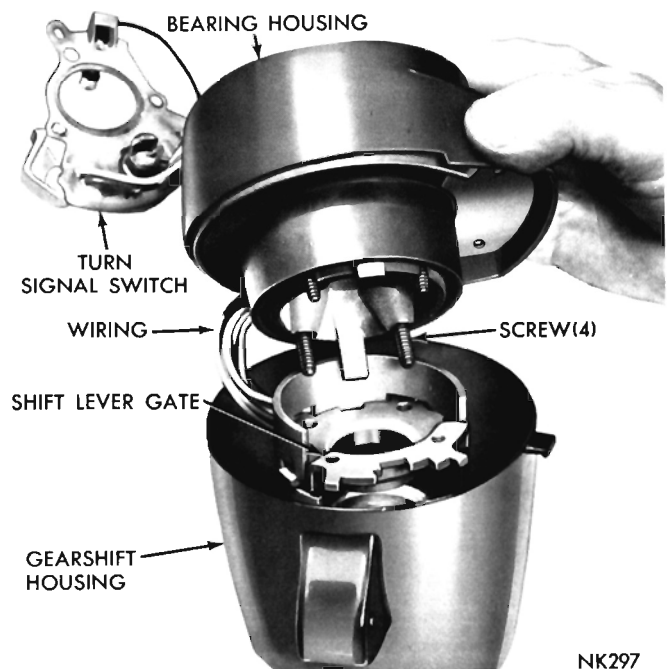

Fig. 13—Disassembling or Assembling Upper End of Column (AR-1, AR-2, AV-1, AV-2 Models)

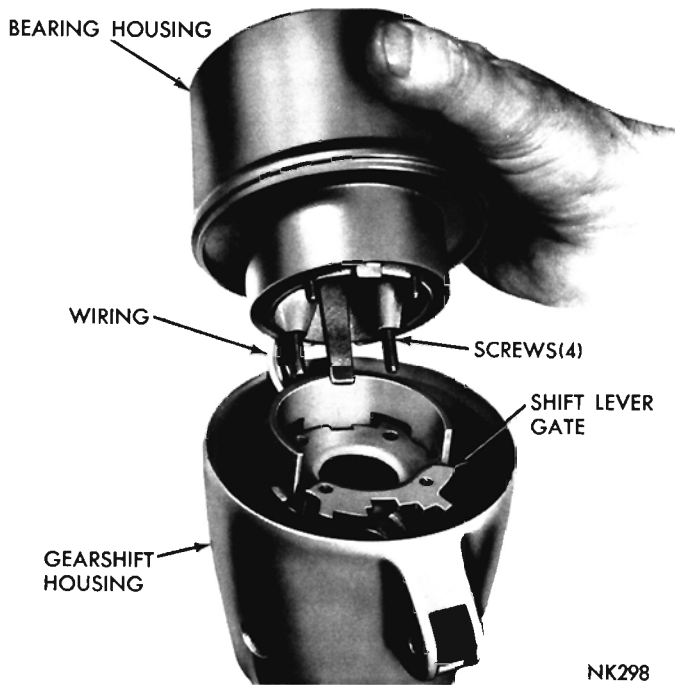

Fig. 14—Disassembling or Assembling Upper End of Column (AP-1, AP-2 Models)

screws from the slotted holes in the column jacket and lift out the sprag lever pivot and nylon washer. Remove the sprag lever and the detent pawl. Remove two screws and lift off the detent plate. Remove the cable bracket.

(8) Rotate the gearshift housing to align opening with the tapered lock bolt. Remove the lock bolt with an Allen wrench (Fig. 12). With lock bolt removed, carefully pull the gearshift tube assembly out of the column jacket.

(9) Remove the turn signal switch retainer from the bearing housing and lift the switch upward out of the way (Fig. 13 or 14). Remove four screws from inside the bearing housing to separate it from the shift lever gate. Slide the gate out of the column jacket.

If necessary, tap the column bearing out of the bearing housing.

(10) Lift the gearshift housing off the column jacket and remove wave washer from the hub counterbore (Fig. 15 or 16). If necessary, remove the shift lever crossover spring load parts (Fig. 15 or 16).

Assembly

During assembly, apply a light film of Multi-Mileage Lubricant or Automotive Multi-Purpose Grease Grade 2, to all parts in the column where friction occurs or where lubrication would be required.

(1) If removed, install the insulator sleeve, column support plate and lower lever seal (boot) on the column jacket before assembling other parts.

(2) Install the shift lever crossover spring load parts in the gearshift housing (Fig. 15 or 16). Be sure all of the parts move freely in the bore, then install the retaining screw. Coat the wave washer with heavy grease and place it in the hub counterbore.

(3) Install the column upper bearing in the bearing housing, make sure the bearing is fully seated in the housing.

(4) With the column jacket held upright, place the gearshift and bearing housings on the jacket. Thread the turn signal switch, horn and indicator lamp wires through the two housings, down into the column jacket and out through the proper opening on the side of the jacket.

(5) Raise the bearing housing and slide the shift lever gate into the upper end of the column jacket (Fig. 13 or 14). Place the four retaining screws in the bearing housing (note the screw lengths (Fig. 13 or 14). Lower the bearing housing and progressively thread the screws into the shift lever gate, then tighten the screws securely.

(6) Slide the spacer and felt washer on the gearshift tube. Install the coil spring (**closed coil end first**) on the upper end of the gearshift tube. Slide the tube assembly into the column, making sure the spring will

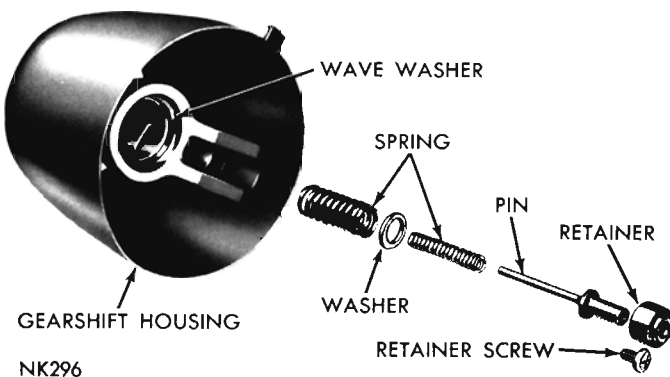

Fig. 15—Gearshift Housing—Disassembled (AR-1, AR-2, AV-1, AV-2 Models)

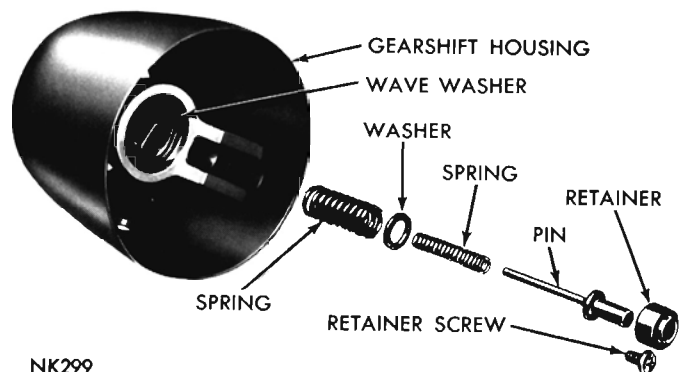

Fig. 16—Gearshift Housing—Disassembled (AP-1, AP-2 Models)

easily push the tube outward when hand pressure is released.

(7) Refer to Figure 11, and install the detent plate with screws finger tight. Install the detent pawl and sprag lever. **Do not install the pawl spring.** Install nylon washer and sprag lever pivot. Press the pivot inward by hand (against spring tension) far enough to start the three screws through the slotted holes in the column jacket. Do not tighten the screws.

(8) Rotate the gearshift housing to align it so the tapered lock bolt can be installed with an Allen wrench (Fig. 12). Tighten the lock bolt securely.

(9) With the gearshift housing in NEUTRAL position, insert the gearshift lever. Support the gearshift housing (Fig. 10) while driving the shift lever roll pin into place.

(10) **The gearshift lever must be held firmly in the LOW position while adjusting the sprag lever, pivot and detent plate.** Adjust by rotating the sprag lever pivot clockwise until the slot in the sprag lever is tight against the pin (Fig. 17), then tighten the three pivot screws. Install the pawl spring, then adjust the detent plate to align the end detent with the pin on the detent pawl. Tighten the detent plate screws. Move the gearshift lever in and out of LOW several times and inspect the adjustment.

(11) Install the cable bracket (Fig. 11) and tighten the two retaining screws. Slide the seal (boot) down in position over the cable bracket.

(12) Install the parking sprag cable first, secure it to the sprag lever pin with the hair pin lock (Fig. 9). Install the gearshift cable, secure it to the shift arm pin with the hair pin lock. Align the seal boot and cable lock plates, then install the rubber washer, metal washer and nut. Tighten the nut securely.

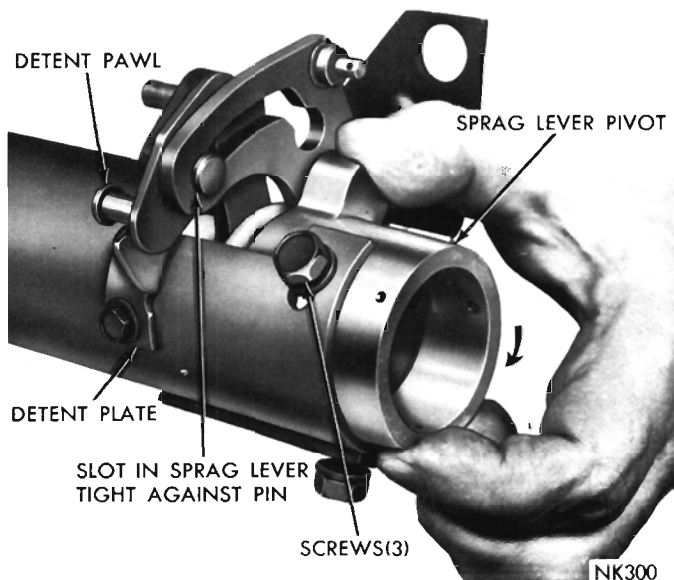

Fig. 17—Adjusting Sprag Lever and Detent Plate

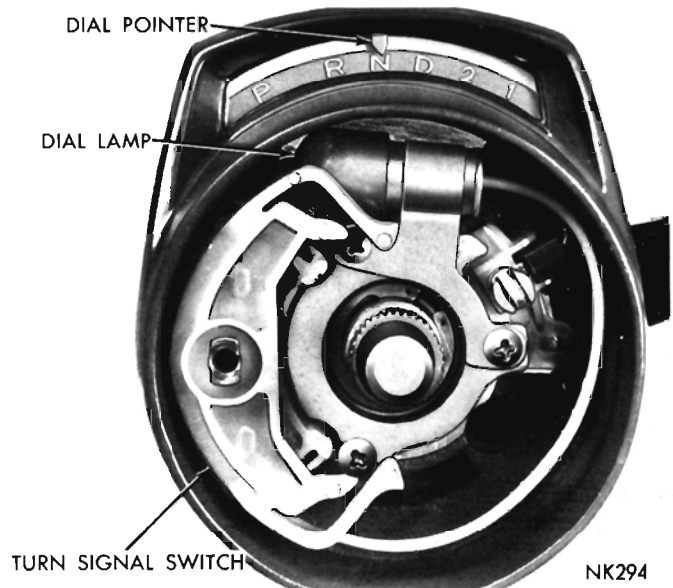

Fig. 18—Turn Signal Switch and Gearshift Indicator

NOTE: The parking sprag cable lock plate must be next to the seal boot, with the gearshift cable lock plate on top of the sprag cable lock plate.

(13) Install the column jacket lower seal and plate, and secure with the three screws. Position edge of seal boot over the plate flange (Fig. 8).

(14) **AR-1, AR-2, AV-1, AV-2 Models:** Position the turn signal switch in the bearing housing, install switch retainer plate, dial lamp and secure with the three screws (Fig. 18). Guide the dial pointer over the dial, then snap the base of the pointer on the lug provided on the gearshift housing.

(15) Slide the steering shaft and lower bearing assembly in the column. Tap the shaft through the upper bearing, then install the snap ring (Fig. 5).

(16) **AR-1, AR-2, AV-1, AV-2 Models:** Place the gearshift lever in NEUTRAL position and snap the back-up lamp switch operating lever on the lug provided on the gearshift tube, slide the washer down over the lever to lock it in place (Fig. 6). Install and adjust the switch so the actuator arm is snug against the operating lever, then tighten the switch retaining screws.

AP-1, AP-2 Models: Place the gearshift lever in the NEUTRAL position and slide the back-up switch operating lever in the groove provided in the gearshift tube, then tighten the locking nut (Fig. 7). Install and adjust the switch so the actuator arm is snug against the operating lever, then tighten the switch retaining screws.

Installation

CAUTION: When installing the steering column,

extreme care must be taken to avoid kinking the cables and/or damaging the back-up light switch.

(1) Route the cables downward along the steering shaft so they enter the floor pan opening first, then carefully guide lower end of the column through the opening.

(2) With the master splines on the worm shaft and the coupling aligned, engage the coupling with the worm shaft.

(3) Loosely fasten the steering column to the instrument panel bracket with the clamp and two screws. Be sure the tab on the clamp is entered in the locating slot in the column jacket.

(4) Using a soft mallet, tap the steering shaft coupling down into place on the worm shaft, then install the lock bolt.

AP-1 and AP-2 Models: Install the heat shield on the lower end of the column jacket.

(5) The steering shaft coupling must be centered at the midpoint of its travel.

AV-1 and AV-2 Models with Power Steering: Move the column assembly up or down in the instrument panel bracket so the dimension between the top of the coupling and the jacket seal is $\frac{1}{2}$ inch (Fig. 19). Tighten the steering column bracket clamp screws securely.

AR-1 and AR-2 Models, Also AV-1 and AV-2 Models with Manual Steering: Move the column assembly up or down in the instrument panel bracket so the dimension between the top of the coupling and the center of the gauge hole (Fig. 20) is $\frac{13}{16}$ inch. Tighten the steering column bracket clamp screws securely.

AP-1 and AP-2 Models: Move the column assembly up or down in the instrument panel bracket so the

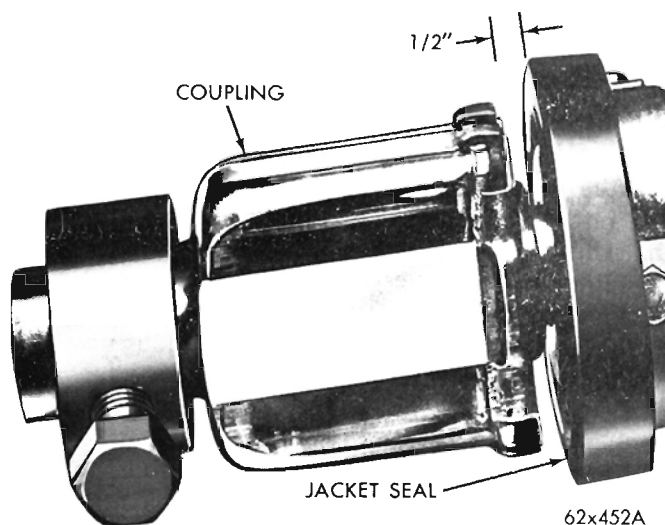

Fig. 19—Positioning Steering Shaft Coupling
(AV-1, AV-2 Models with Power Steering)

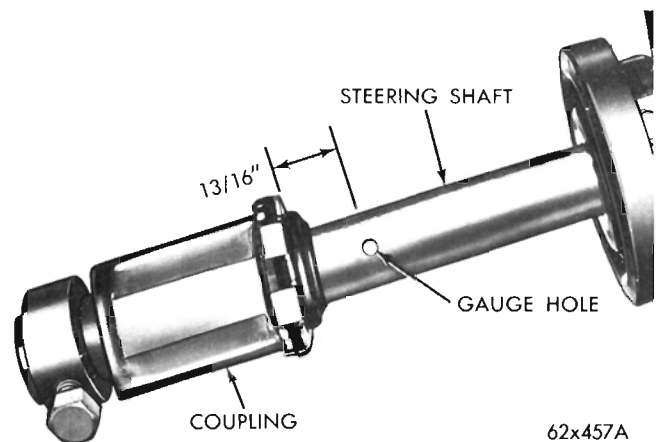

Fig. 20—Positioning Steering Shaft Coupling
(AR-1, AR-2 Models, Also AV-1, AV-2 with Manual Steering)

rear edge of the coupling boot aligns with the gauge hole in the shaft (Fig. 21). Tighten the steering column bracket clamp screws securely.

(6) **AP-1 and AP-2 Models:** Connect the gearshift indicator link (slotted end) to the operating lever on the column with the screw in its approximate original location. Slowly move the gearshift lever from "1" (low) to "P" (park) pausing briefly at each selector position. The indicator pointer must travel and align with each selector position in a positive manner without hesitation. If necessary, loosen the screw and re-adjust the link to align the pointer correctly.

(7) Attach the finish plate to the bottom of the instrument panel. Align and attach the floor plate to the floor pan. Connect brake pedal to the master cylinder. Install the turn signal lever.

(8) With the master splines in the steering wheel hub and steering shaft aligned, place the steering wheel on the steering shaft. Install the retaining nut and washer, tighten the nut to 24 foot-pounds torque.

(9) Connect the horn wire to the switch, install the horn switch, insulators and retaining screws. Install

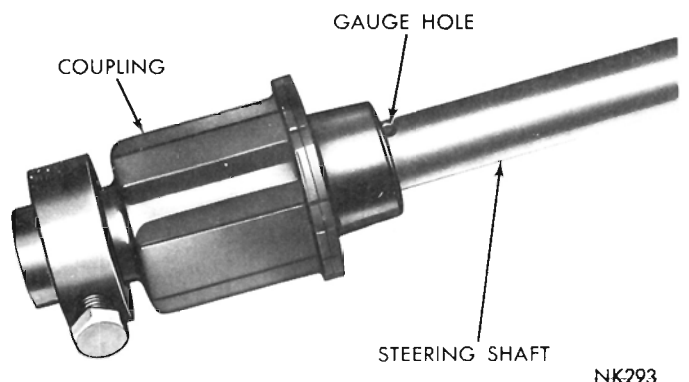

Fig. 21—Positioning Steering Shaft Coupling
(AP-1, AP-2 Models)

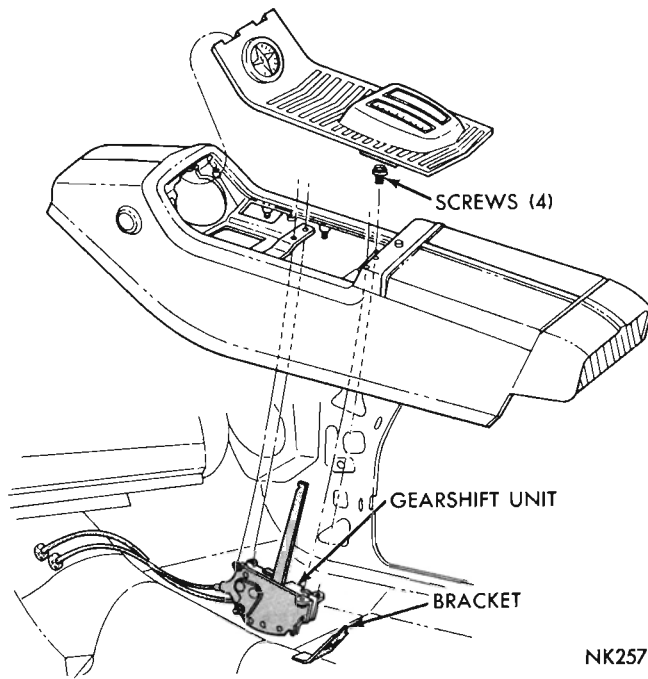

Fig. 22—Removing or Installing Console
(AP-1, AP-2, AR-1, AR-2 Models)

the horn button.

(10) Connect the turn signal, gearshift indicator light and horn wires. Connect the battery ground cable, test the operation of the lights and horns.

(11) Connect and adjust the gearshift control cable and parking lock cable. Refer to Pages 57 and 58.

CONSOLE GEARSHIFT UNIT

Removal

(1) Disconnect the negative (ground) cable from the battery.

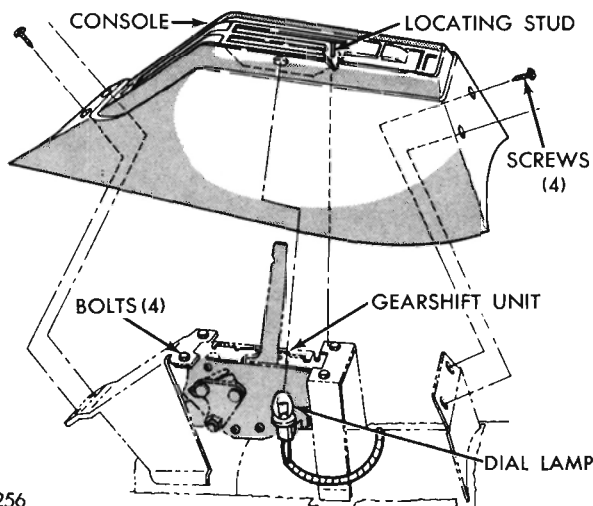

Fig. 23—Removing or Installing Console
(AV-1, AV-2 Models)

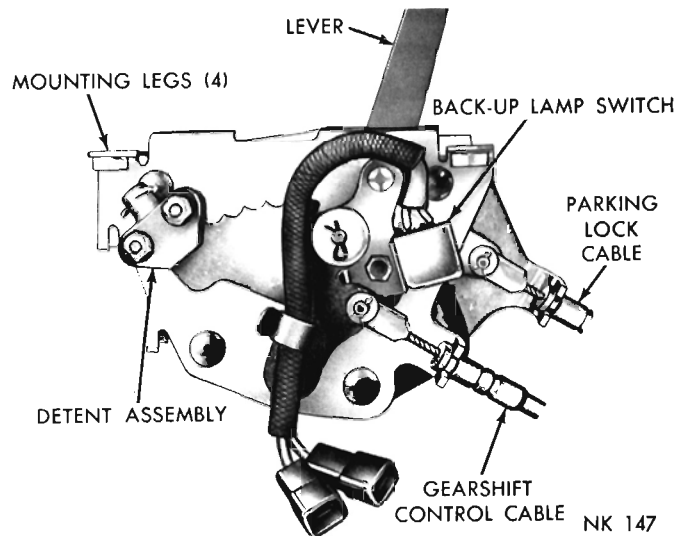

Fig. 24—Console Gearshift Unit

NOTE: If the gearshift and/or parking lock cables are to be replaced, disconnect them from the transmission. Refer to Pages 57 and 58.

(2) Remove the set screw from the gearshift lever knob and remove the knob.

(3) **AP-1, AP-2, AR-1, AR-2 Models:** Remove the screws from the rear end of the console upper finish plate (Fig. 22). Raise the rear end of the plate and work it rearward to disengage it from the front of the console. Lift the plate upward far enough to remove the dial lamp and socket, then lift off the plate. Remove the four gearshift unit to console retaining bolts.

Raise the console lid, remove two screws from bottom of the tray, securing console to the floor rear mounting bracket.

Carefully raise the lower edge of the console side trim and loosen the console-to-floor bracket mounting bolts (two bolts on each side of console). Loosen the bolts several turns but do not remove.

Disconnect the courtesy lamp wires and any other electrical connections, then lift off the console assembly.

(4) **AV-1, AV-2 Models:** Remove four screws securing the console to the floor mounting brackets (Fig. 23). Lift the console upward far enough to remove the dial lamp and socket, then lift off the console assembly. Remove the four gearshift unit to floor bracket retaining bolts.

(5) Disconnect the two cable and housings from the unit. Disconnect the back-up lamp switch wires (Fig. 24).

(6) Attach a piece of soft wire about four feet long to the end of each cable. Coat the cable housings with lubricant, then carefully pull the cable assemblies down through the floor grommets. Disconnect and leave the wires in the floor to route the cables during reinstallation.

Adjustment

With the selector lever in the **REVERSE** position, look through the clearance hole to see if scribe mark (Fig. 25) on the control lever, lines up with the center of the sprag lever guide pin.

To adjust, loosen the lock nut and rotate the cam to align the scribe mark with the center of the guide pin. Hold the cam in this position and tighten the cam lock nut to 95 inch-pounds torque.

Installation

(1) Attach the wires securely to the ends of the cables. Carefully guide the cables through the floor grommets while pulling upward on the wires. Securely attach the cables and housings to the gearshift unit. Connect the back-up lamp switch wires.

(2) **AP-1, AP-2, AR-1, AR-2 Models:** Place the gearshift unit on the temporary floor pan bracket to hold it in place while installing the console (Fig. 22).

Lower the console down over the shift lever and connect the courtesy lamp wires and other electrical connections. Position the console on the floor mounting brackets, make sure the retaining bolt flat washers are outside of the console flange, then tighten the four bolts securely. Install and tighten the two retaining screws in the bottom of the console tray.

Lift the gearshift control unit off the temporary bracket. Align the unit in the console, install and tighten the four retaining bolts.

Position the finish plate over the shift lever, slide the three tabs on front end of the plate under the moulding, and lower the finish plate far enough to install the dial lamp and socket. Lower the rear of the finish plate into position and install the retaining screws.

(3) **AV-1, AV-2 Models:** Align the gearshift control unit in the mounting brackets, install and tighten the four retaining bolts (Fig. 23).

Lower the console down over the shift lever far enough to install the dial lamp and socket. Lower the console down into position making sure the locating stud enters the mounting bracket. Install and tighten the four retaining screws.

(4) Install the gearshift lever knob and secure with the set screw.

(5) Inspect the cables for proper routing. Make sure there are no sharp kinks or interference with other parts.

(6) Connect the battery ground cable. Adjust the gearshift and parking lock control cables. Refer to Pages 57 and 58.

GEAR SHIFT CONTROL CABLE

(Transmission End)

Removal

(1) Place the selector lever in **PARK** position, and raise the vehicle on a hoist.

(2) Remove the gearshift control cable to transmission adjusting wheel lock screw. Pull the cable outward just enough to allow the fluid to drain into a container.

(3) Pull the cable out of the transmission case as far as possible, back off the adjusting wheel a few turns if necessary.

(4) Insert a small screw driver above and slightly to the right of the cable (Fig. 26). Disengage the cable adapter lock spring by pushing the screw driver handle to the right while pulling outward on the cable.

Installation

(1) Place the selector lever in the **PARK** position.

(2) Back the adjustment wheel off on the cable housing (counter-clockwise) until two or three threads are showing on the guide behind the wheel.

(3) Lubricate the cable housing with transmission

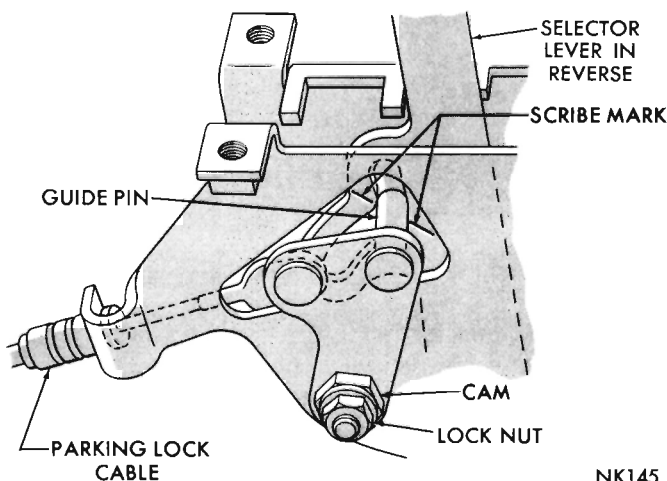

Fig. 25—Parking Lock Control Adjustment

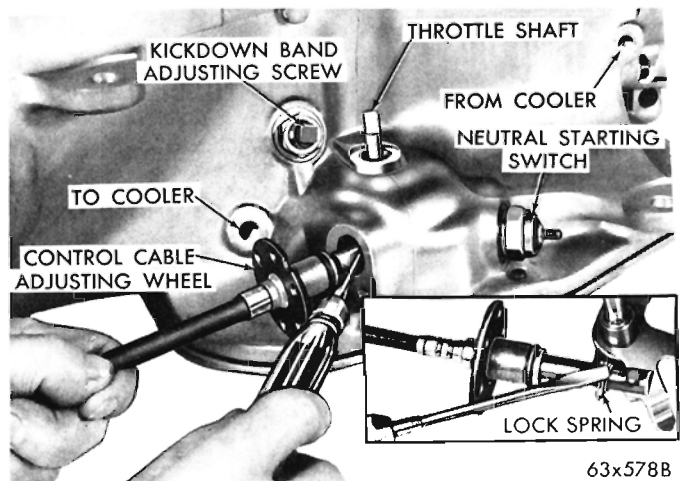

Fig. 26—Removing Gearshift Control Cable

fluid, insert the cable in the transmission case, push inward on the cable making sure the lock-spring engages the cable.

Adjustment

(4) Have an assistant hold the selector lever firmly in the 1 (low) position. Hold the control cable centered in the hole of the transmission case and pull the cable outward (approximately two pounds) to bottom the assembly in the low detent. While holding the cable outward, rotate the adjustment wheel **clockwise** until it just contacts the case squarely.

Turn the wheel **counter-clockwise** just enough to make the next adjustment hole in the wheel line up with the screw hole in the case. Counting this hole as number one, continue turning the wheel **counter-clockwise** until the fifth hole lines up with the screw hole in the case.

(7) Push the cable and adjusting wheel tight against the case then install the lock screw and tighten to 75 inch-pounds torque.

(8) Refill the transmission with Automatic Transmission Fluid Type "A" Suffix "A" to the proper level. Refer to Page 49.

PARKING LOCK CABLE

(Transmission End)

Removal

(1) Loosen the parking lock cable clamp bolt where the cable enters the housing cover (Fig. 27). Tap the end of the clamp bolt lightly to release its hold on the cable. Remove the housing cover lower plug.

(2) With a screw driver inserted through the plug opening, push gently against the projecting portion of the cable lock-spring, then withdraw the lock cable.

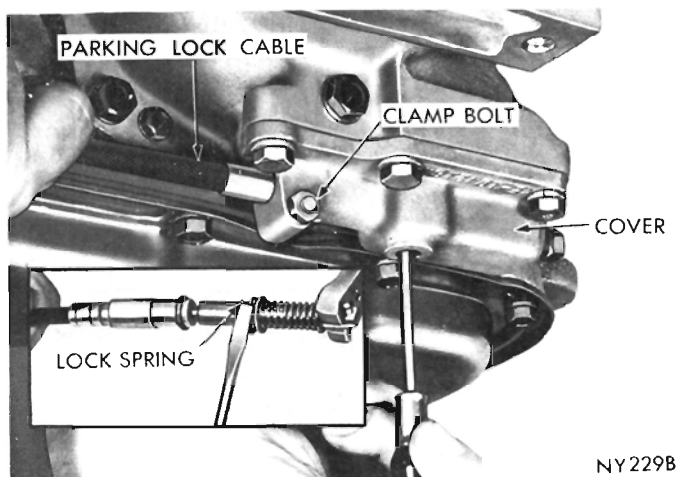

Fig. 27—Removing Parking Lock Cable

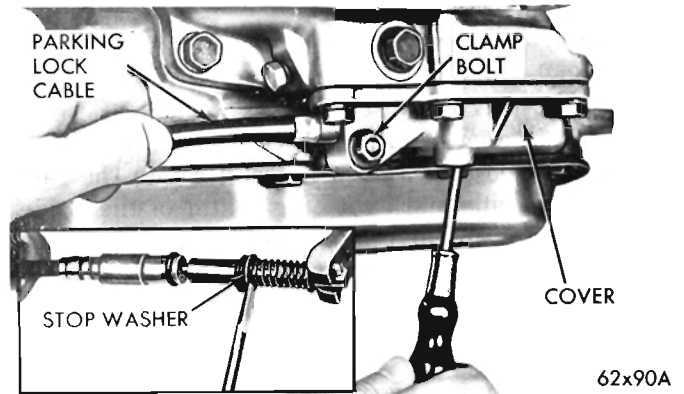

Fig. 28—Installing Parking Lock Cable

CAUTION: Do not use pliers or similar tool to withdraw the cable from the adapter cover as the cable cover might be damaged causing an oil leak.

Installation

(1) Place the selector lever in the NEUTRAL position.

(2) Insert a screw driver through the plug opening and position it behind the cable adapter stop washer (Fig. 28). Hold the adapter outward while pushing the cable in as far as possible, making sure the lockspring engages the cable.

(3) Gently pull outward on the cable housing to its limit of travel, release and then tighten the clamp bolt to 10 inch-pounds torque. Reinstall the plug in the cover and tighten to 75 inch-pounds torque.

CAUTION: Do not use pliers or similar tool to pull outward on the cable as the cable cover might be damaged causing an oil leak.

(4) Test the adjustments by allowing the vehicle to roll slowly on a slight incline. The parking sprag should fully engage the gear with the lever in the PARK position, and there should be no ratcheting noise with the lever in the NEUTRAL position.

NEUTRAL STARTING SWITCH

Adjustment and Test

The neutral starting switch (Fig. 29) should operate in both the PARK and NEUTRAL selector lever positions.

(1) To test the switch, disconnect the wire from the switch.

(2) Connect one lead of a test lamp to battery current and the other lead to the switch terminal. If the test lamp does not light, the switch may be faulty, out of adjustment, or the gearshift control cable may be improperly adjusted.

(3) Unscrew the switch from the transmission case allowing the fluid to drain into a container. Move the



Fig. 29—Neutral Starting Switch

selector lever to the PARK and then to the NEUTRAL positions, and inspect to see that the switch operating lever fingers are centered in the switch opening in the case.

(4) Screw the switch into the transmission case and tighten to 25-35 foot-pounds torque. Retest the switch with the test lamp.

(5) Add fluid to the transmission to bring up to the proper level. Refer to Page 49.

NOTE: Test the starter for operating in all selector lever positions. If it should operate in any position other than selector lever park and neutral, readjust the gearshift control cable. Refer to Page 57. In some cases, it may be necessary to align the valve body neutral and/or park fingers with the switch plunger. Refer to Page 75.

BAND ADJUSTMENTS

Kickdown Band

The kickdown band adjusting screw is located on the left side of the transmission case near the throttle lever shaft (Fig. 26).

(1) Loosen the lock nut and back off approximately five turns. Test the adjusting screw for free turning in the transmission case.

(2) Using wrench, Tool C-3380 with adapter C-3705, tighten the band adjusting screw 47 to 50 inch-pounds torque. If adapter C-3705 is not used, tighten the adjusting screw to 72 inch-pounds which is the true torque.

(3) **A-904-G and A-904-LA:** Back off the adjusting screw 2 turns (225 and 273 cu. in. engines), and 2½ turns (170 cu. in. engine). Hold the adjusting screw in this position and tighten the lock nut to 25 foot-pounds torque.

A-727-A and B: Back off the adjusting screw 2 turns. Hold the adjusting screw in this position and tighten the lock nut to 29 foot-pounds torque.

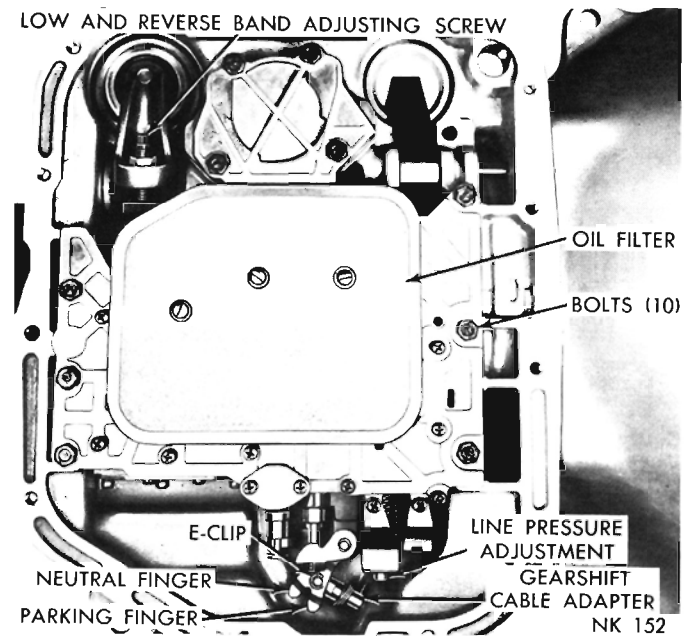

Fig. 30—Bottom View of Transmission (Pan Removed)

Low and Reverse Band

(1) Raise the vehicle, drain the transmission fluid and remove the oil pan.

(2) Loosen the adjusting screw lock nut and back off nut approximately five turns (Fig. 30). Test the adjusting screw for free turning in the lever.

(3) Using wrench, Tool C-3380 with adapter C-3705, tighten the band adjusting screw 47 to 50 inch-pounds torque. If adapter C-3705 is not used, tighten the adjusting screw to 72 inch-pounds which is the true torque.

(4) **A-904-G and A-904-LA:** Back off the adjusting screw 5¼ turns. Hold adjusting screw in this position and tighten the lock nut to 20 foot-pounds torque.

A-727-A and B: Back off the adjusting screw 3 turns. Hold adjusting screw in this position and tighten the lock nut to 35 foot-pounds torque.

(5) Reinstall the oil pan using a new gasket. Tighten the oil pan bolts to 150 inch-pounds torque.

(6) Fill the transmission with Automatic Transmission Fluid Type "A" Suffix "A." Refer to Page 49.

THROTTLE LINKAGE ADJUSTMENT

With the engine at operating temperature and the carburetor off the fast idle cam, adjust the idle speed of the engine using a tachometer. Refer to the "Fuel System" Group 14, for the idle speed Specifications.

Automatic Transmission (Fig. 31)
(Model AP-2 with 318-383 or 426 Cu. In. Eng.)

(1) Apply a thin film of multi-purpose grease on

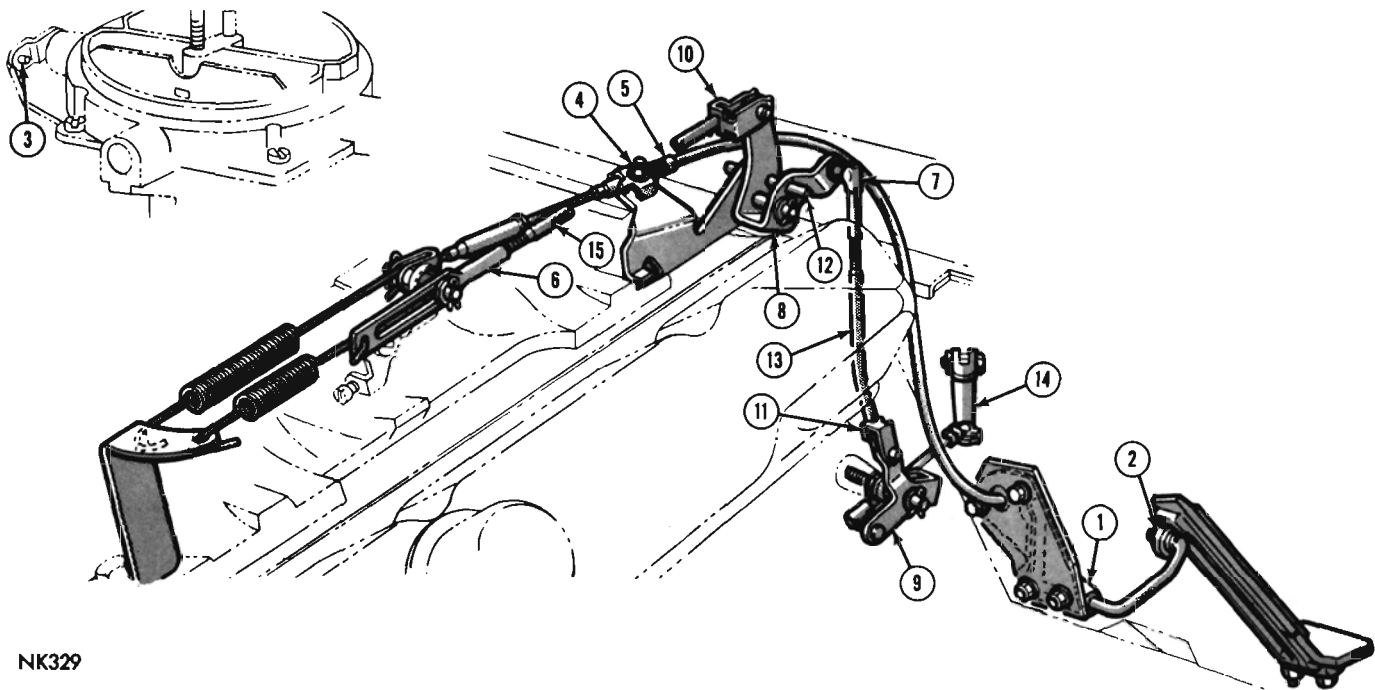

NK329

Fig. 31—Throttle Linkage Adjustment—Model AP-2 with 318-383 or 426 Cu. In. Eng.

both ends of the accelerator shaft [1] where it turns in the bracket, nylon roller [2] where it contacts the pedal, pivot points of both upper [8] and lower [9] transmission linkage bellcranks, also the clipped ends of transmission linkage rod bearing areas [10] [11].

(2) Disconnect the return spring and slotted transmission rod [6] from the carburetor lever pin. Disconnect the transmission intermediate rod ball socket [7] from the upper bellcrank ball end.

(3) Disconnect choke [3] at carburetor or block choke valve in full open position. Open throttle slightly to release fast idle cam, then return carburetor to curb idle.

(4) With a $\frac{3}{16}$ inch diameter rod [12] placed in the holes provided in the upper engine mounted bellcrank and lever [8], adjust the length of the intermediate transmission rod [13] by means of the threaded adjustment at the upper end. The ball socket [7] must line up with the ball end with the rod held upward against the transmission stop [14].

(5) Assemble ball socket [7] to ball end and remove $\frac{3}{16}$ inch rod [12] from upper bellcrank and lever.

(6) Hold the carburetor rod [15] forward against the transmission stop [14] and adjust its length by means of the threaded adjustment so that the rear end of the slot in the adjusting link [6] just contacts the carburetor lever pin.

(7) Lengthen the carburetor rod [15] two full turns by turning the slotted link [6].

(8) Assemble slotted link [6] to the carburetor.

(9) Loosen the cable clamp nut [4], then adjust the

position of the cable housing ferrule [5] in the clamp so that all slack is removed from the cable with the carburetor at curb idle. To remove slack from the cable, move the ferrule [5] in the clamp in the direction **away** from the carburetor lever.

(10) Back off ferrule [5] $\frac{1}{4}$ inch. This provides $\frac{1}{4}$ inch cable slack at idle. Tighten cable clamp nut [4].

(11) Route cable so it does not interfere with the carburetor rod [15] or upper bellcrank [8] throughout full throttle linkage travel.

(12) Connect choke rod [3] or remove blocking fixture.

Manual Transmission (Fig. 31)

(Model AP-2 with 318-383 or 426 Cu. In. Eng.)

(1) Apply a thin film of multi-purpose grease on both ends of the accelerator shaft [1] where it turns in the bracket, and nylon roller [2] where it contacts the pedal.

(2) Disconnect choke [3] at carburetor or block choke valve in full open position. Open throttle slightly to release fast idle cam, then return carburetor to curb idle.

(3) Loosen the cable clamp nut [4], then adjust the position of the cable housing ferrule [5] in the clamp so that the slack is removed from the cable with the carburetor at curb idle. To remove slack from the cable move the ferrule [5] in the clamp in the direction **away** from the carburetor lever.

(4) Back off ferrule [5] $\frac{1}{4}$ inch. This provides $\frac{1}{4}$

inch cable slack at idle. Tighten cable clamp nut [4].

(5) Connect choke rod [3] or remove blocking fixture.

Automatic Transmission (Fig. 32)

(Model AR-2 with 361-383 or 426 Cu.

In. Eng.)

(1) Apply a thin film of multi-purpose grease on both ends of the accelerator shaft [1] where it turns in the bracket, and nylon roller [7] where it contacts the pedal.

(2) Disconnect the return spring and slotted transmission rod [5] from the carburetor lever pin.

(3) Disconnect choke [2] at carburetor or block choke valve in full open position. Open throttle slightly to release fast idle cam, then return carburetor to curb idle.

(4) Hold the transmission lever [6] forward against its stop (rod or lever must not be moved vertically while holding against the stop) and adjust the length of the transmission rod by means of the threaded adjustment [5] at the upper end. The rear end of the slot should contact the carburetor lever pin without exerting any forward force.

(5) Lengthen rod by one full turn of the adjustment.

(6) Assemble slotted adjustment [5] to carburetor lever pin and install washer and retainer pin. Assemble transmission linkage return spring in place. To check transmission linkage freedom of operation, move slotted adjuster link [5] to the full rearward position, then allow it to return slowly, making sure it returns to the full forward position.

(7) Loosen the cable clamp nut [4], then adjust the

position of the cable housing ferrule [3] in the clamp so that all slack is removed from the cable with the carburetor at curb idle. To remove slack from the cable, move the ferrule [3] in the clamp in the direction **away** from the carburetor lever.

(8) Back off ferrule [3] ¼ inch. This provides ¼ inch cable slack at idle. Tighten cable clamp nut [4].

(9) Route cable so that it does not interfere with the transmission rod throughout its full travel.

(10) Connect choke rod [2] or remove blocking fixture.

Manual Transmission (Fig. 32)

(Model AR-2 with 361-383 or 426 Cu.

In. Eng.)

(1) Apply a thin film of multi-purpose grease on both ends of the accelerator shaft [1] where it turns in the bracket, and nylon roller [7] where it contacts the pedal.

(2) Disconnect choke [2] at carburetor or block choke valve in full open position. Open throttle slightly to release fast idle cam, then return carburetor to curb idle.

(3) Loosen the cable clamp nut [4], then adjust the position of the cable housing ferrule [3] in the clamp so that all slack is removed from the cable with the carburetor at curb idle. To remove slack from the cable move the ferrule [3] in the clamp in the direction **away** from the carburetor lever.

(4) Back off ferrule [3] ¼ inch. This provides ¼ inch cable slack at idle. Tighten cable clamp nut [4].

(5) Connect choke rod [2] or remove blocking fixture.

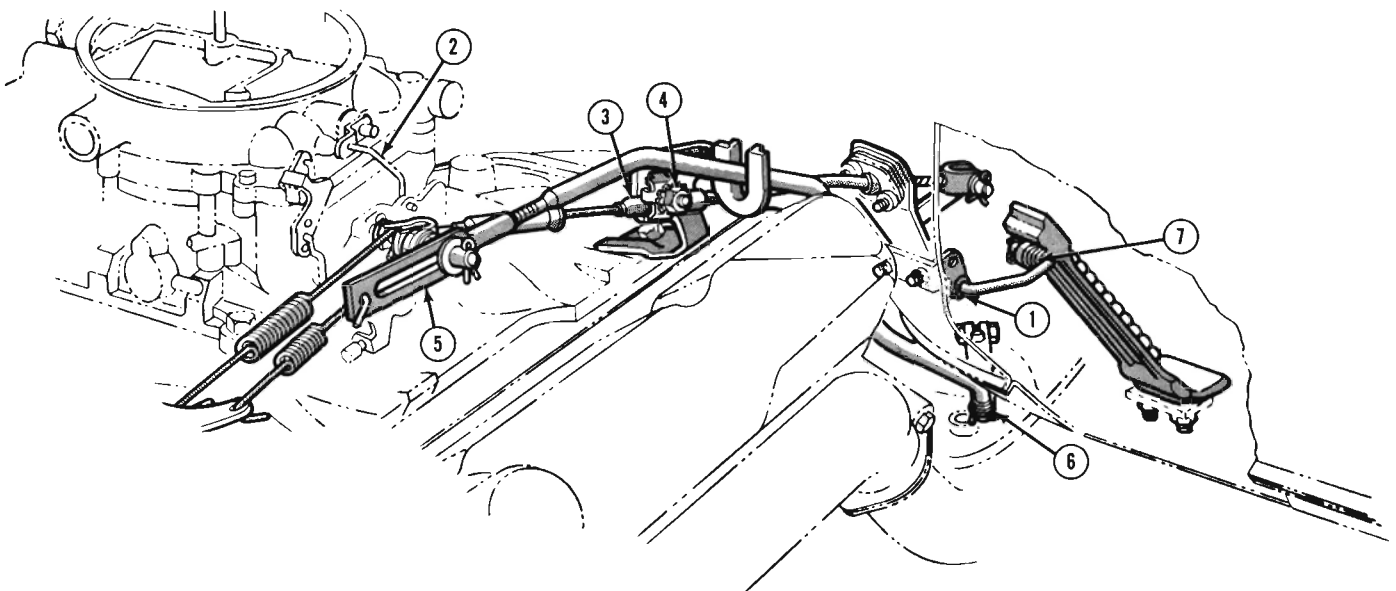

NK330

Fig. 32—Throttle Linkage Adjustment—Model AR-2 with 361-383 or 426 Cu. In. Eng.

Automatic Transmission (Fig. 33)
(Model AR-2 with 273 or 318 Cu. In. Eng.)
In. Eng.)

(1) Apply a thin film of multi-purpose grease on both ends of the accelerator shaft [1] where it turns in the bracket, and nylon roller [7] where it contacts the pedal.

(2) Disconnect the return spring and slotted transmission rod [5] from the carburetor lever pin.

(3) Disconnect choke [2] at carburetor or block choke valve in full open position. Open throttle slightly to release fast idle cam, then return carburetor to curb idle.

(4) Hold the transmission lever [6] forward against its stop (rod or lever must not be moved vertically while holding against the stop) and adjust the length of the transmission rod by means of the threaded adjustment [5] at the upper end. The rear end of the slot should contact the carburetor lever pin without exerting any forward force.

(5) Lengthen rod by one turn of the adjustment.

(6) Assemble slotted adjustment [5] to carburetor lever pin and install washer and retainer pin. Assemble transmission linkage return spring in place. To check transmission linkage freedom of operation, move slotted adjuster link [5] to the full rearward position, then allow it to return slowly, making sure it returns to the full forward position.

(7) Loosen the cable clamp nut [4], then adjust the position of the cable housing ferrule [3] in the clamp so that all slack is removed from the cable with the carburetor at curb idle. To remove slack from the cable, move the ferrule [3] in the clamp in the direction

away from the carburetor lever.

(8) Back off ferrule [3] $\frac{1}{4}$ inch. This provides $\frac{1}{4}$ inch cable slack at idle. Tighten cable clamp nut [4].

(9) Route cable so that it does not interfere with the transmission rod throughout its full travel.

(10) Connect choke rod [2] or remove blocking fixture.

Manual Transmission (Fig. 33)
(Model AR-2 with 273 or 318 Cu. In. Eng.)

(1) Apply a thin film of multi-purpose grease on both ends of the accelerator shaft [1] where it turns in the bracket, and nylon roller [7] where it contacts the pedal.

(2) Disconnect choke [2] at carburetor or block choke valve in full open position. Open throttle slightly to release fast idle cam, then return carburetor to curb idle.

(3) Loosen the cable clamp nut [4], then adjust the position of the cable housing ferrule [3] in the clamp so that all slack is removed from the cable with the carburetor at curb idle. To remove slack from the cable move the ferrule [3] in the clamp in the direction away from the carburetor lever.

(4) Back off ferrule [3] $\frac{1}{4}$ inch. This provides $\frac{1}{4}$ inch cable slack at idle. Tighten cable clamp nut [4].

(5) Connect choke rod [2] or remove blocking fixture.

Automatic Transmission (Fig. 34)
(Models AP-1, AR-1 with 225 Cu. In. Eng.)

(1) Apply a thin film of multi-purpose grease on

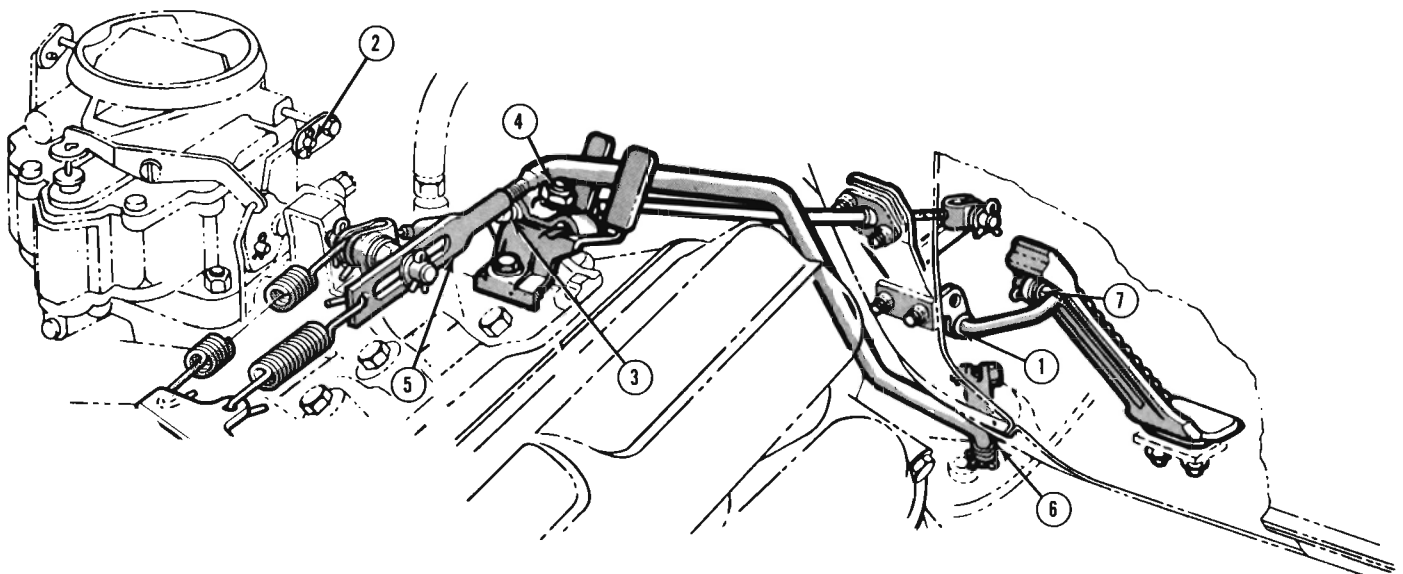

NK331

Fig. 33—Throttle Linkage Adjustment—Model AR-2 with 273 or 318 Cu. In. Eng.

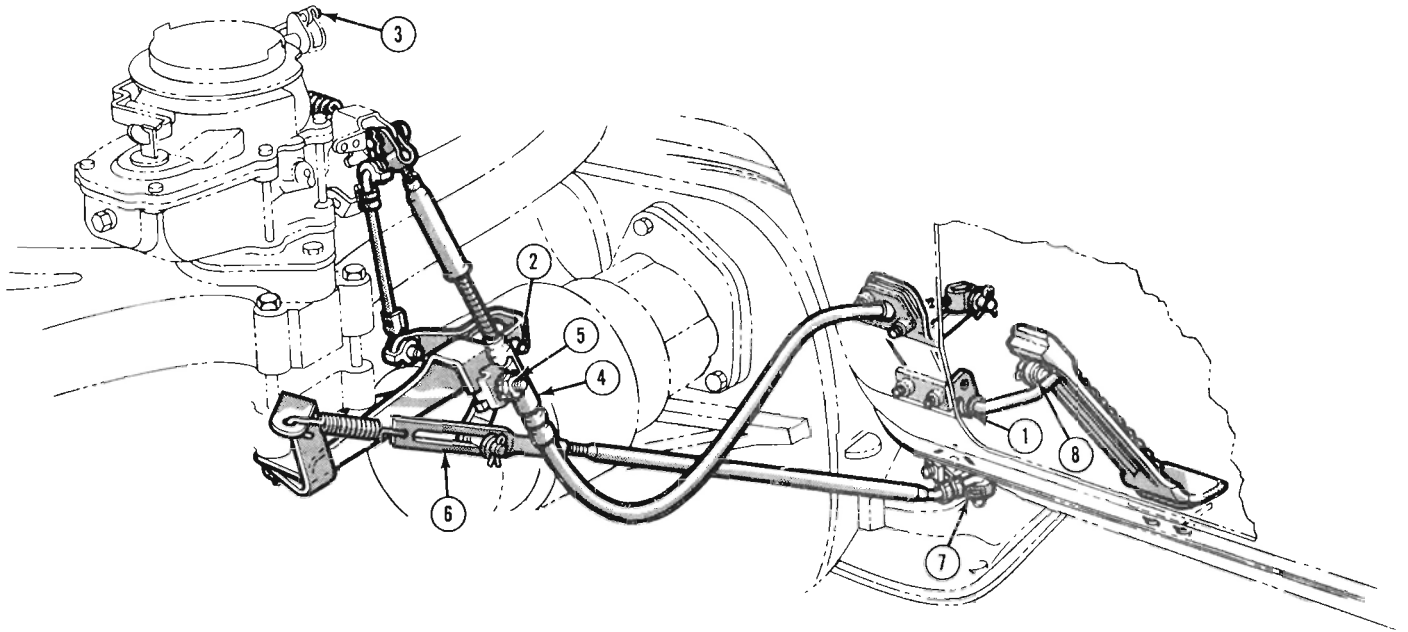

NK332

Fig. 34—Throttle Linkage Adjustment—Model AP-1, AR-1 with 225 Cu. In. Eng.

both ends of the accelerator shaft [1] where it turns in the bracket, nylon roller [8] where it contacts the pedal, and the bellcrank pin [2].

(2) Disconnect the return spring and slotted transmission rod [6] from the bellcrank lever pin.

(3) Disconnect choke [3] at carburetor or block choke valve in full open position. Open throttle slightly to release fast idle cam, then return carburetor to curb idle.

(4) Hold the transmission lever [7] forward against its stop (rod or lever must not be moved vertically while holding against the stop) and adjust the length of the transmission rod by means of the threaded adjustment [6] at the upper end. The rear end of the slot should contact bellcrank lever pin without exerting any forward force.

(5) Lengthen rod by one full turn of the adjustment.

(6) Assemble slotted adjustment [6] to bellcrank lever pin and install washer and retainer pin. Assemble transmission linkage return spring in place. To check transmission linkage freedom of operation, move slotted adjuster link [6] to the full rearward position, then allow it to return slowly, making sure it returns to the full forward position.

(7) Loosen the cable clamp nut [5], then adjust the position of the cable housing ferrule [4] in the clamp so that all slack is removed from the cable with the carburetor at curb idle. To remove slack from the cable, move the ferrule [4] in the clamp in the direction **away** from the carburetor lever.

(8) Back off ferrule [4] $\frac{1}{4}$ inch. This provides $\frac{1}{4}$ inch cable slack at idle. Tighten cable clamp nut [5].

(9) Route cable so that it does not interfere with the transmission rod throughout its full travel.

(10) Connect choke rod [3] or remove blocking fixture.

Manual Transmission (Fig. 34)

(Models AP-1, AR-1 with 225 Cu. In. Eng.)

(1) Apply a thin film of multi-purpose grease on both ends of the accelerator shaft [1] where it turns in the bracket, and nylon roller [8] where it contacts the pedal.

(2) Disconnect choke [3] at carburetor or block choke valve in full open position. Open throttle slightly to release fast idle cam, then return carburetor to curb idle.

(3) Loosen the cable clamp nut [5], then adjust the position of the cable housing ferrule [4] in the clamp so that all slack is removed from the cable with the carburetor at curb idle. To remove slack from the cable move the ferrule [4] in the clamp in the direction **away** from the carburetor lever.

(4) Back off ferrule [4] $\frac{1}{4}$ inch. This provides $\frac{1}{4}$ inch cable slack at idle. Tighten cable clamp nut [5].

(5) Connect choke rod [3] or remove blocking fixture.

Automatic Transmission (Fig. 35)

(Model AV-2 with 273 Cu. In. Eng.)

(1) Apply a thin film of multi-purpose grease to both ends of the accelerator shaft [3] where it turns in

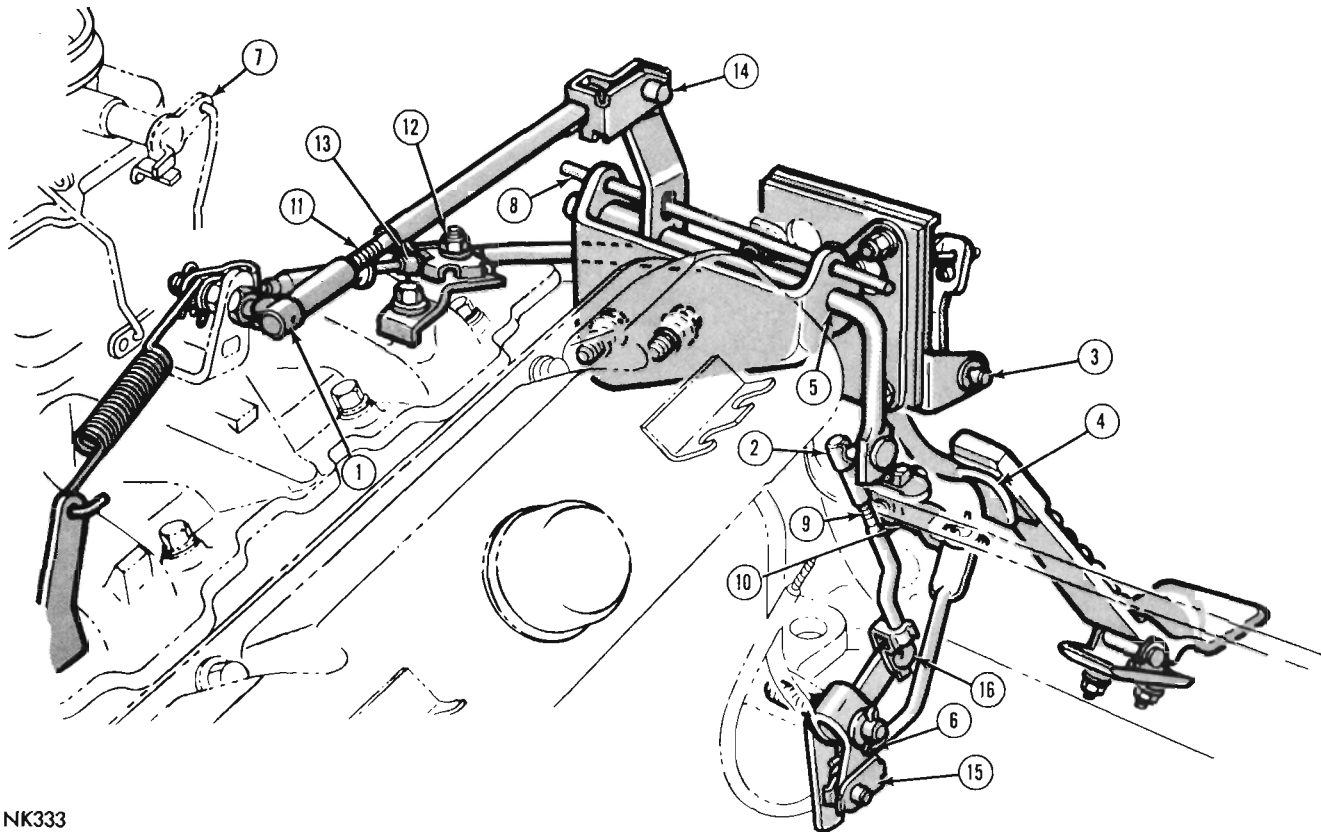

NK333

Fig. 35—Throttle Linkage Adjustment—Model AV-2 with 273 Cu. In. Eng.

the bracket, and bottom side of the pedal [4] where it contacts accelerator shaft lever. Also to pivot points of both upper [5] and lower [6] bellcranks, and the clipped ends of transmission linkage rod bearing areas [14] [15] and [16].

(2) Disconnect the return spring and carburetor rod ball socket [1] from carburetor or disconnect the transmission intermediate rod ball socket [2] from the upper bellcrank ball end.

(3) Disconnect choke [7] at carburetor or block choke valve in full open position. Open throttle slightly to release fast idle cam, then return carburetor to curb idle.

(4) Insert a 6 inch long $\frac{3}{16}$ inch diameter rod in the holes provided in the upper engine mounted bellcrank [5] and lever, adjust the length of the intermediate transmission rod by means of the threaded adjustment [9] at the upper end. The ball socket must line up with the ball end with the rod held downward against the transmission stop [10].

(5) Assemble ball socket [2] to bell end and remove $\frac{3}{16}$ inch rod [8] from upper bellcrank [5] and lever.

(6) Hold the carburetor rod [11] forward against the transmission stop [10] and adjust its length by means of the threaded adjustment [11] so that the ball socket [1] lines up with the ball end of the carburetor lever.

(7) Lengthen carburetor rod four turns by turning

ball socket [1] counterclockwise.

(8) Assemble ball socket [1] to ball end and connect the return spring.

(9) Loosen the cable clamp nut [12], then adjust the position of the cable housing ferrule [13] in the clamp so that all slack is removed from the cable with the carburetor at curb idle. To remove slack from the cable, move the ferrule [13] in the clamp in the direction **away** from the carburetor lever.

(10) Back off ferrule [13] $\frac{1}{4}$ inch. This provides $\frac{1}{4}$ inch cable slack at idle. Tighten cable clamp nut [12].

(11) Route cable so that it does not interfere with the transmission rod throughout its full travel.

(12) Connect choke rod [7] or remove blocking fixture.

Manual Transmission (Fig. 35)

(Model AV-2 with 273 Cu. In. Eng.)

(1) Apply a thin film of multi-purpose grease to both ends of the accelerator shaft [3] where it turns in the bracket, and bottom side of the pedal [4] where it contacts accelerator shaft lever.

(2) Disconnect choke [7] at carburetor or block choke valve in full open position. Open throttle slightly to release fast idle cam, then return carburetor to curb idle.

(3) Loosen the cable clamp nut [12], then adjust the

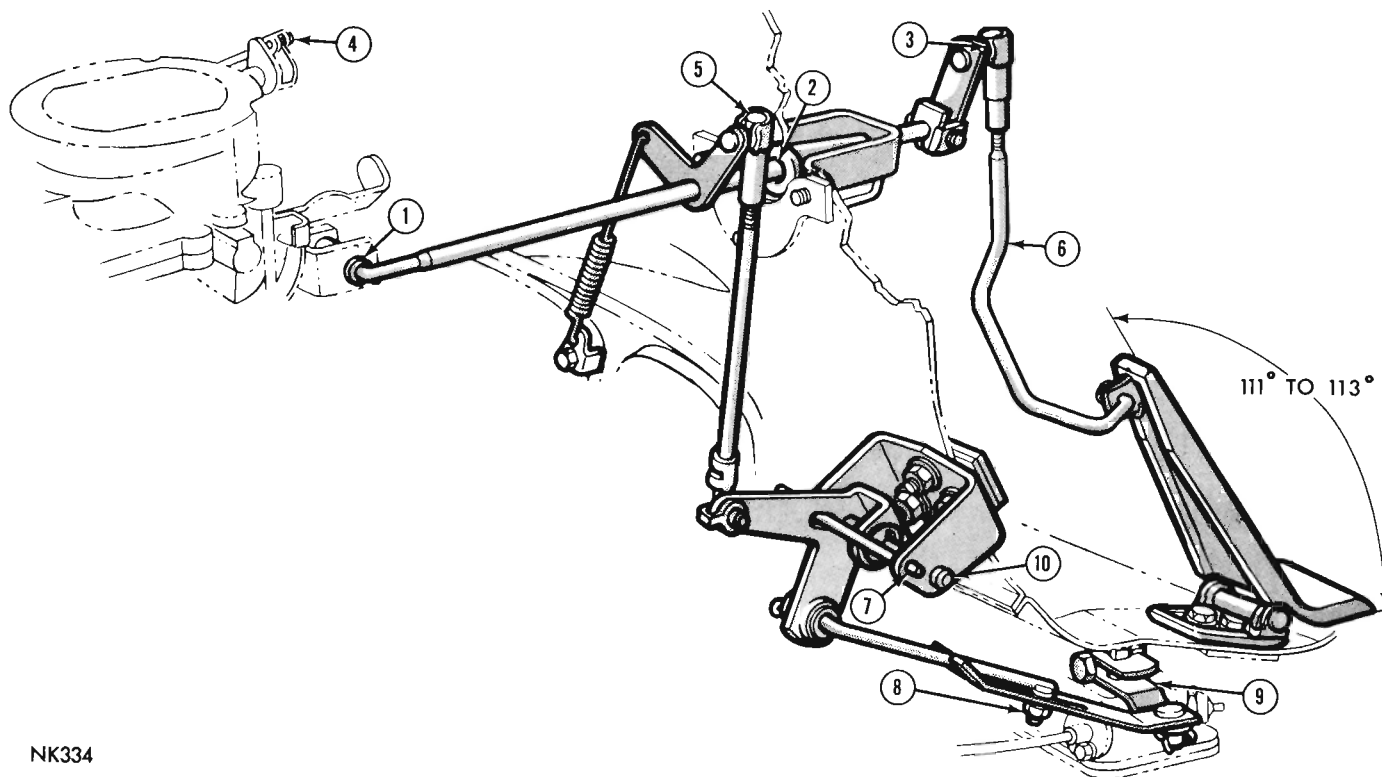

Fig. 36—Throttle Linkage Adjustment—Model AV-1 with 170 or 225 Cu. In. Eng.

NK334

position of the cable housing ferrule [13] in the clamp so that all slack is removed from the cable with the carburetor at curb idle. To remove slack from the cable, move the ferrule [13] in the clamp in the direction **away** from the carburetor lever.

(4) Back off ferrule [13] $\frac{1}{4}$ inch. This provides $\frac{1}{4}$ inch cable slack at idle. Tighten cable clamp nut [12].

(5) Connect choke rod [7] or remove blocking fixture.

Automatic Transmission (Fig. 36) (Model AV-1 with 170 or 225 Cu. In. Eng.)

(1) Apply a thin film of multi-purpose grease on the outside surface of carburetor lever isolator [1], and torque shaft plastic bushing [2], also the torque shaft ball stud [3] and bellcrank pin [10].

(2) Disconnect the transmission intermediate rod ball socket [5] from the bellcrank ball end.

(3) Disconnect choke at carburetor [4] or block choke valve in full open position. Open throttle slightly to release fast idle cam, then return throttle to curb idle.

(4) Loosen lock nut [8] in the transmission rod, insert a $\frac{3}{16}$ inch diameter rod [7] approximately [4] inches long in the holes provided in the transmission rod bellcrank bracket and lever assembly.

(5) Move the transmission lever [9] forward against the stop and tighten the transmission rod lock nut [8].

(6) Disconnect the top end of the accelerator pedal rod [6]. Adjust the length of this rod to provide a pedal angle of 111° to 113° . To increase pedal angle, increase the length of this rod by means of the screw adjustment. Reinstall the top end of the rod [6].

(7) Remove the $\frac{3}{16}$ inch diameter rod [7] from the transmission rod bracket and lever assembly. Adjust the length of the transmission bellcrank to torque shaft rod by means of the screw adjustment at top end. The correct rod length allows the ball socket to line up with the ball end when the rod is held upward against the transmission stop.

(8) Install the ball socket on torque shaft lever ball end [5].

(9) Connect choke rod [4] or remove blocking fixture.

Manual Transmission (Fig. 36) (Model AV-1 With 170 or 225 Cu. In. Eng.)

(1) Apply a thin film of multi-purpose grease on the outside surface of carburetor lever isolator [1], and torque shaft plastic bushing [2], also the torque shaft ball stud [3].

(2) Disconnect choke at carburetor [4] or block choke valve in full open position. Open throttle slightly to release fast idle cam, then return throttle to curb idle.

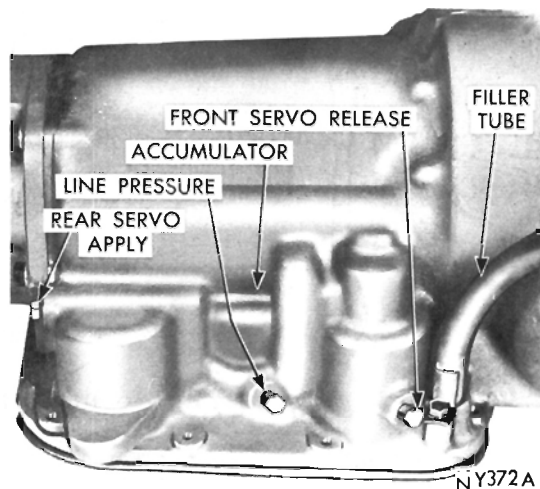

Fig. 37—Pressure Test Locations (Right Side of Case)

(3) Disconnect top end of accelerator pedal rod [6]. Adjust the length of this rod to provide a pedal angle of 111° to 113° . To increase pedal angle, increase the length of this rod by means of the screw adjustment. Reinstall the top end of the rod [6]. Connect choke [4] rod or remove blocking fixture.

HYDRAULIC CONTROL PRESSURE TESTS

Line Pressure and Front Servo

Release Pressure

Line pressure and front servo release pressure tests must be made in D (drive) position with the rear wheels free to turn. The transmission fluid must be at operating temperature (150 to 200° F).

(1) Install an engine tachometer, raise the vehicle on a hoist and position the tachometer so it can be read under the vehicle.

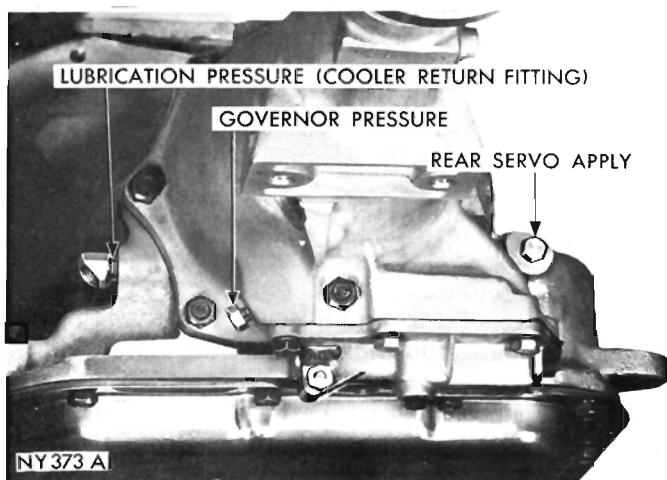

Fig. 38—Pressure Test Locations (Rear End of Case)

(2) Connect two 0-100 psi pressure gauges, Tool C-3292 to the pressure take-off-points at the side of the accumulator and at the front servo release (Fig. 37).

(3) With the control in D (drive) position, speed up the engine slightly until the transmission shifts into direct. (Front servo release will be pressurized in direct.) Reduce the engine speed slowly to 1,000 rpm. Line pressure at this time (1,000 rpm) must be 54-60 psi, and the front servo release pressure must not be more than 3 psi below the line pressure.

(4) Disconnect the throttle linkage from the transmission throttle lever and move the throttle lever gradually to the full throttle position. Line pressure must rise to a maximum of 90-96 psi just before or at kickdown into low gear. Front servo release pressure must follow the line pressure up to the kickdown point and should not be more than 3 psi below the line pressure.

If the pressure is not 54-60 psi at 1,000 rpm, adjust the pressure, as outlined on Page 67.

If the front servo release pressures are less than the pressures specified and line pressures are within limits, there is excessive leakage in the front clutch and/or front servo circuits. **Always inspect the external transmission throttle lever for looseness on the valve body shaft when making the pressure tests.**

Lubrication Pressures

The lubrication pressure test should be made at the same time that line pressure and front servo release pressure are tested.

(1) Install a "tee" fitting between the cooler return line fitting and the fitting hole in the transmission case at the rear of left side of the transmission (Fig. 38). Connect a 0-100 psi pressure gauge, Tool C-3292 to the "tee" fitting.

(2) At 1,000 engine rpm, with the throttle closed and transmission in direct, lubrication pressure should be 5-15 psi. Lubrication pressure will be approximately doubled as the throttle is opened to maximum line pressure.

Rear Servo Apply Pressure

(1) Connect a 0-300 psi pressure gauge, Tool C-3293 to the apply pressure take-off point at the rear servo (Fig. 38).

(2) With the transmission control in R (reverse) position and the engine speed set at 1600 rpm, the reverse servo apply pressure should be 240-280 psi.

Governor Pressure

(1) Connect a 0-100 psi pressure gauge, Tool C-3292 to the governor pressure take-off point, located at the lower left side of the extension near the mounting flange (Fig. 38).

(2) Governor pressures should fall within the limits given in the "Governor Pressure Chart."

GOVERNOR PRESSURE CHART

(Six Cylinder Vehicles)

VEHICLE SPEED TO AXLE RATIOS

AV1		AR1		AP1		PRESSURE LIMITS PSI
6.50-13	3.55:1	7.35-14	3.55:1	7.35-14	3.23:1	
16-17	14-16	17-19	14-16	17-19	15-17	.. 15
36-45	33-41	36-47	30-38	36-47	33-42	.. 50
59-67	53-61	62-71	51-59	62-71	56-65	.. 75

GOVERNOR PRESSURE CHART

(Eight Cylinder Vehicles)

VEHICLE SPEED TO AXLE RATIOS

AV2		AR2		AP2		PRESSURE LIMITS PSI
7.00-13	3.23:1	7.35-14	3.23:1	7.75-14	3.23:1	
18-19	16-17	17-19	15-17	18-20	16-18	.. 15
40-51	37-46	36-47	33-42	38-47	35-42	.. 50
66-75	60-68	62-71	56-65	65-72	59-65	.. 75

GOVERNOR PRESSURE CHART

(426 Cubic Inch Engine)

VEHICLE SPEED TO AXLE RATIOS

7.75-14		PRESSURE LIMITS PSI
3.23:1	3.91:1	
16-18	13-15	.. 15
45-51	37-42	.. 50
67-73	55-60	.. 75

If the governor pressures are incorrect at the given vehicle speeds, the governor valve and/or weights are probably sticking.

NOTE: The governor pressure should respond smoothly to changes in mph and should return to 0 to 1½ psi when the vehicle is stopped. High pressure at stand still (above 2 psi) will prevent the transmission from downshifting.

Throttle Pressure

No provisions are made to test the throttle pressure. Incorrect throttle pressure should only be suspected if the part throttle shift speeds are either very delayed or occur too early in relation to vehicle

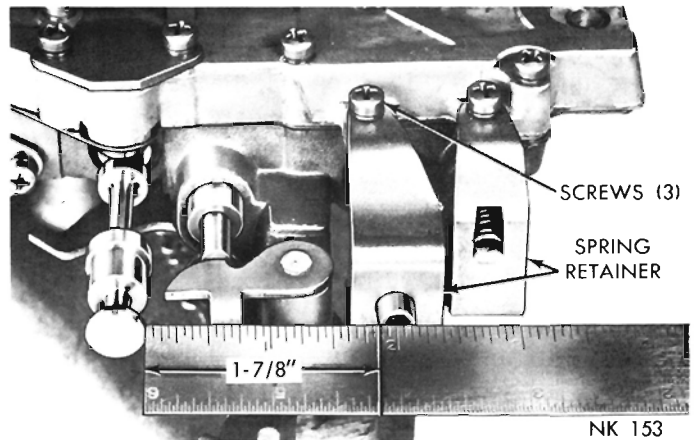

Fig. 39—Measuring Spring Retainer Location

speeds. In which case, the throttle linkage should be adjusted before throttle pressure setting is adjusted. Refer to Page 59.

HYDRAULIC CONTROL PRESSURE ADJUSTMENTS

Line Pressure

An incorrect throttle pressure setting will cause incorrect line pressure readings even though the line pressure adjustment is correct. Always inspect and correct the throttle pressure adjustment before adjusting the line pressure.

NOTE: Before adjusting the line pressure, measure the distance between the manual valve (valve in 1-low position) and line pressure adjusting screw (Fig. 39). This measurement must be 1⅞ inches; correct by loosening the spring retainer screws and repositioning the spring retainer. The regulator valve may cock and hang up in its bore if the spring retainer is out of position.

If the line pressure is not correct, it will be necessary to remove the valve body assembly to perform the adjustment. Refer to Page 75.

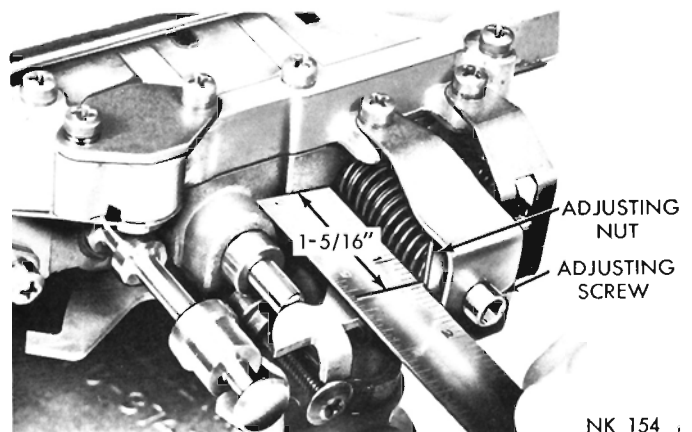

Fig. 40—Line Pressure Adjustment

The approximate adjustment is $1\frac{5}{16}$ inches, measured from the valve body to the inner edge of the adjusting nut (Fig. 40). However, due to manufacturing tolerances, the adjustment can be varied to obtain the specified line pressure.

The adjusting screw may be turned with an Allen wrench. One complete turn of the adjusting screw changes closed throttle line pressure approximately $1\frac{2}{3}$ psi. Turning the adjusting screw counter-clockwise increases pressure, and clockwise decreases the pressure.

Throttle Pressure

Throttle pressures cannot be tested accurately; therefore, the adjustment should be measured if a malfunction is evident.

(1) Remove the valve body assembly from the transmission to perform the adjustment. (Refer to Page 75).

(2) Loosen the throttle lever stop screw lock nut and back off approximately five turns (Fig. 41).

(3) Insert gauge pin of Tool C-3763 between the throttle lever cam and the kickdown valve.

(4) By pushing in on the tool, compress the kickdown valve against its spring so the throttle valve is completely bottomed inside the valve body.

(5) As force is being exerted to compress the spring, tighten the throttle lever stop screw finger tight against the throttle lever tang with the throttle lever cam touching the tool and the throttle valve bottomed.

NOTE: Be sure the adjustment is made with the spring fully compressed and the valve bottomed in the valve body.

(6) Remove the tool and tighten the stop screw lock nut securely.

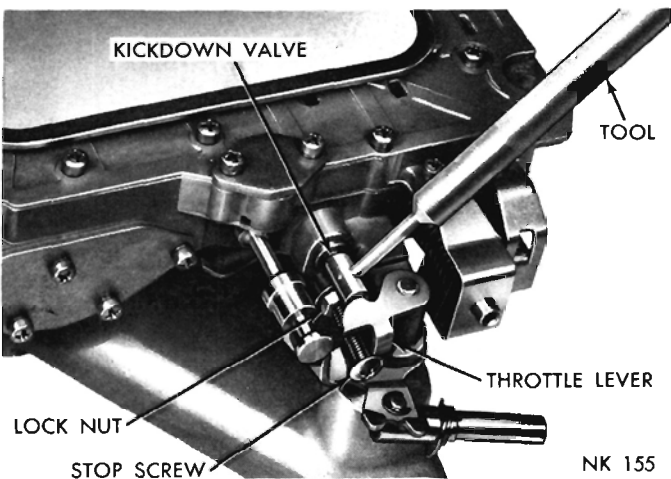

Fig. 41—Throttle Pressure Adjustment

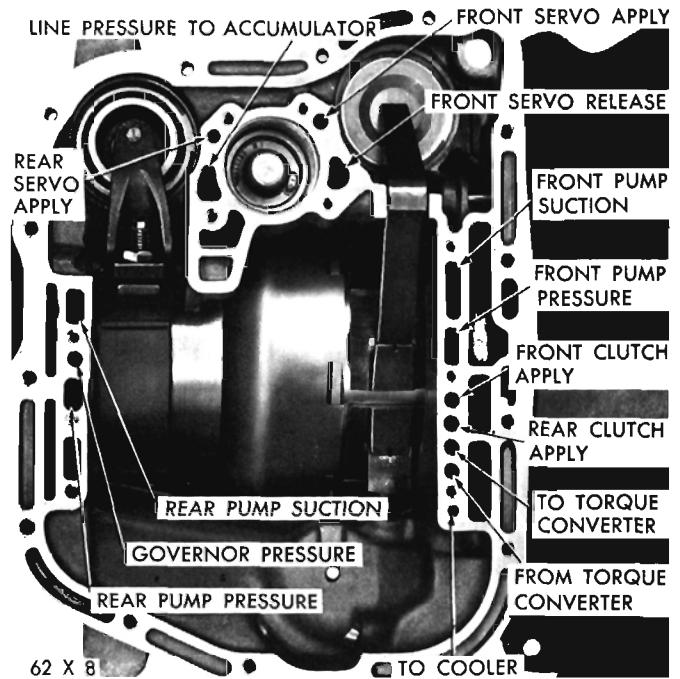

Fig. 42—Air Pressure Tests

AIR PRESSURE TESTS

A "NO DRIVE" condition might exist even with correct fluid pressure, because of inoperative clutches or bands. The inoperative units, clutches, bands and servos can be located through a series of tests by substituting air pressure for the fluid pressure (Fig. 42). The front and rear clutches, kickdown servo, and low-reverse servo may be tested by applying air pressure to their respective passages after the valve body assembly has been removed. Refer to Page 75. To make the air pressure tests, proceed as follows:

CAUTION: Compressed air supply must be free of all dirt or moisture. Use a pressure of 30 to 100 psi.

Front Clutch

Apply air pressure to the front clutch "apply" passage and listen for a dull "thud" which indicates that the front clutch is operating. Hold the air pressure on for a few seconds and inspect the system for excessive oil leaks.

Rear Clutch

Apply air pressure to the rear clutch "apply" passage and listen for a dull "thud" which indicates that the rear clutch is operating. Also inspect for excessive oil leaks.

NOTE: If a dull "thud" cannot be heard in the clutches, place the finger tips on the clutch housing and again apply air pressure. Movement of the piston can be felt as the clutch is applied.

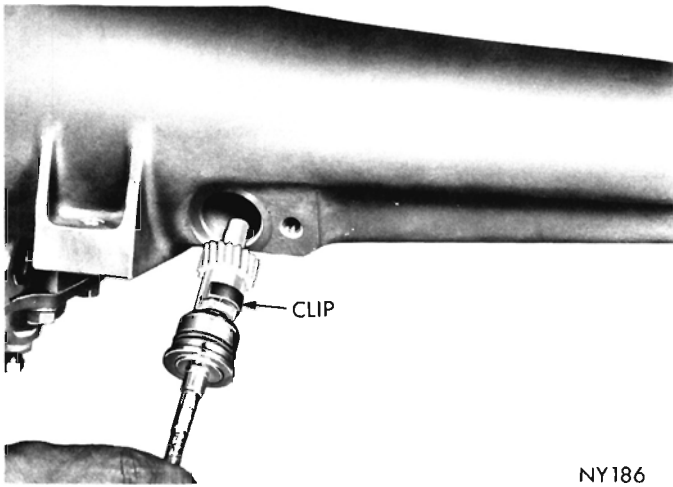

NY186

Fig. 43—Removing or Installing Speedometer Pinion

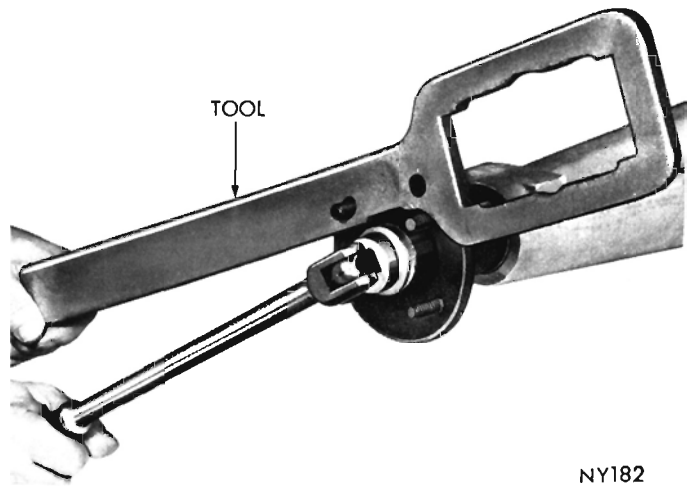

NY182

Fig. 45—Removing or Installing Output Shaft Flange Nut

Kickdown Servo

Direct air pressure into the front servo “apply” passage. Operation of the servo is indicated by a tightening of the front band. Spring tension on the servo piston should release the band.

Low and Reverse Servo

Direct air pressure into the rear servo “apply” passage. Operation of the servo is indicated by a tightening of the rear band. Spring tension on the servo piston should release the band.

If the clutches and servos operate properly, no unshift or erratic shift conditions indicate that the malfunctions exist in the control valve body assembly.

Governor

Governor operating failures can generally be diagnosed by a road test or hydraulic pressure test. Refer to Page 66.

SPEEDOMETER PINION

Removal and Installation

- (1) Remove the screw and retainer securing the speedometer cable to the extension housing. Carefully work the pinion and sleeve assembly out of the housing (Fig. 43).
- (2) To replace the pinion and/or oil seal, pry the clip off the pinion and slide the pinion assembly off the cable. Install a new seal on the cable housing.
- (3) If transmission fluid is found in the cable housing, replace the seal inside the pinion bore (Fig. 44). Pry the old seal out of the pinion bore. Place a new seal on the end of the cable with the lip toward the cable housing, then slide the pinion over the seal and cable. Secure with the spring clip.
- (4) To install, push the pinion and sleeve assembly into the extension housing so the sleeve flange is tight against the housing, then install the retainer and screw. Tighten the screw to 150 inch-pounds torque.

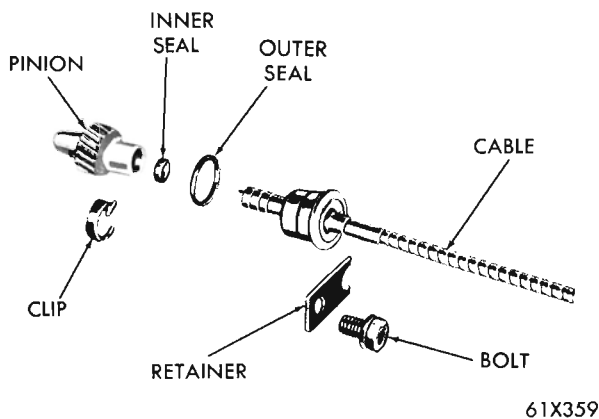

Fig. 44—Speedometer Pinion (Disassembled)

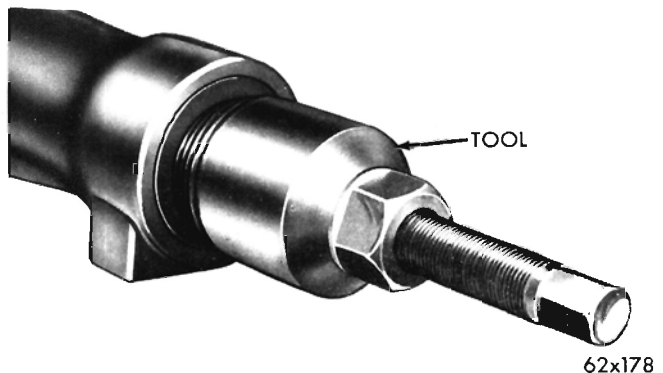

Fig. 46—Removing Output Shaft Oil Seal

OUTPUT SHAFT OIL SEAL

Replacement—A-904-G and A-904-LA

(1) Disconnect the propeller shaft at the transmission flange.

(2) Hold the transmission flange with Tool C-3281 and remove the retaining nut and washer (Fig. 45). Slide the flange off the output shaft. (Use puller Tool C-452 if necessary.)

(3) Screw taper threaded end of Tool C-748 into the seal (Fig. 46), then tighten the screw of tool to remove the seal.

(4) To install a new seal, position the seal in opening of extension housing with lip of the seal facing inward. Drive the seal into housing with Tool C-3837 (Fig. 47).

(5) Install the transmission output shaft flange. Install the washer with its three projections toward the flange and the nut with its convoluted surface contacting the washer. Hold the flange with Tool C-3281, and tighten the nut to 175 foot-pounds torque.

(6) Connect the propeller shaft to the transmission flange.

Replacement—A-727-A and B

(1) Disconnect the propeller shaft at the rear universal joint. Carefully pull the shaft assembly out of the transmission extension housing.

CAUTION: Be careful not to scratch or nick the ground surface on the sliding spline yoke during removal and installation of the shaft assembly.

(2) Cut the boot end off the seal, then screw the taper threaded end of Tool C-748 into the seal (Fig. 48). Tighten the screw of the tool to remove the seal.

(3) To install a new seal, position seal in the opening of the extension housing and drive it into the housing with Tool C-3972 (Fig. 47).

(4) Carefully guide the front universal joint yoke into the extension housing and on the output shaft splines. Then connect the propeller shaft to the rear axle pinion shaft yoke.

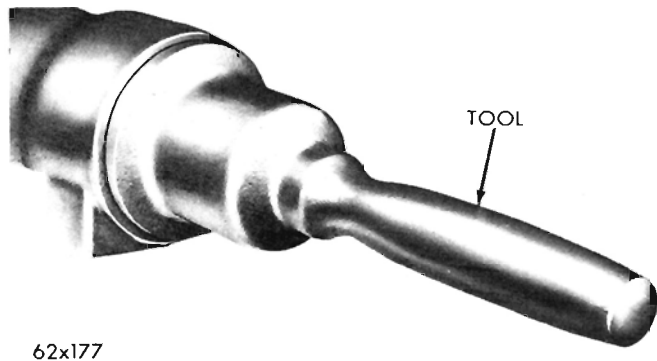

Fig. 47—Installing Output Shaft Oil Seal

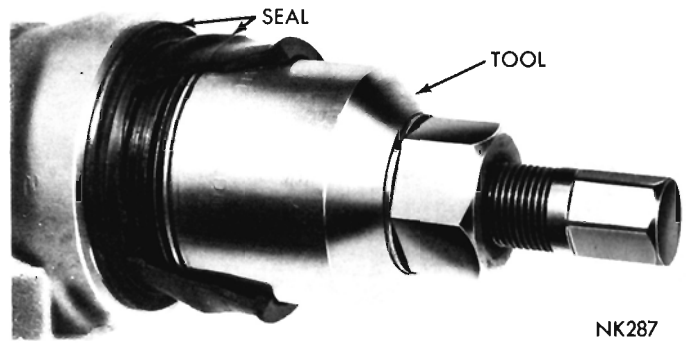

Fig. 48—Removing Output Shaft Oil Seal

**EXTENSION HOUSING AND BEARING—
A-904-G AND A-904-LA**

Removal

(1) Remove the speedometer drive pinion and sleeve assembly. Refer to Page 69.

(2) Remove the transmission flange. Refer to Page 70.

(3) Drain approximately two quarts of fluid from the transmission.

(4) Disconnect the parking lock cable. Refer to Page 58.

(5) Remove the two bolts securing the extension housing to the crossmember insulator.

(6) Raise the transmission slightly to clear the crossmember with service jack, Tool C-3203A. Remove the crossmember attaching bolts and remove the crossmember, insulator and spring assembly.

(7) Remove the extension housing to transmission bolts, **do not pull the long bolt from the housing as it supports the parking sprag**. Tap the housing lightly with a soft mallet to break it loose from the transmission, then carefully remove the housing.

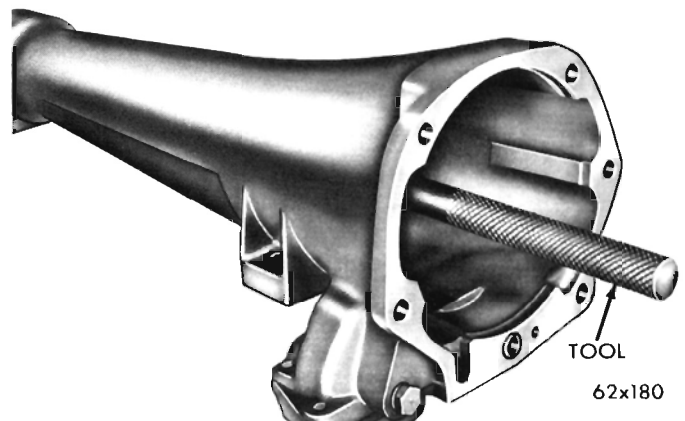

Fig. 49—Removing Output Shaft Bearing

Bearing Replacement

(1) Pry or drive the oil seal out of the extension housing with a long blunt drift. Be sure not to mar the oil seal surface in the housing.

(2) Remove the bearing snap ring from the extension housing. Drive the bearing rearward out of the housing with Tool C-3275 (Fig. 49).

(3) Place a new bearing in the opening of the extension housing. Using Tool C-3204, drive the bearing into housing (Fig. 50). Install the bearing retaining snap ring.

(4) Place a new seal in the opening of the extension housing (lip of seal facing inward). Using Tool C-3837, drive the seal into the housing until tool bottoms (Fig. 47).

Installation

(1) Using a new gasket, carefully slide the extension housing into place, install the retaining bolts and washers, tighten bolts to 24 foot-pounds torque.

(2) Install the crossmember, insulator and spring assembly. Tighten the crossmember attaching bolts to 75 foot-pounds torque. Lower the transmission so the extension housing rests on, and is aligned with the insulator. Install the insulator to extension housing bolts and tighten to 35 foot-pounds torque.

(3) Install and adjust the parking lock cable. Refer to Page

(4) Install the transmission flange and connect the propeller shaft.

(5) Install the speedometer drive pinion and sleeve.

(6) Add fluid to the transmission to bring it up to the proper level. Refer to Page 49.

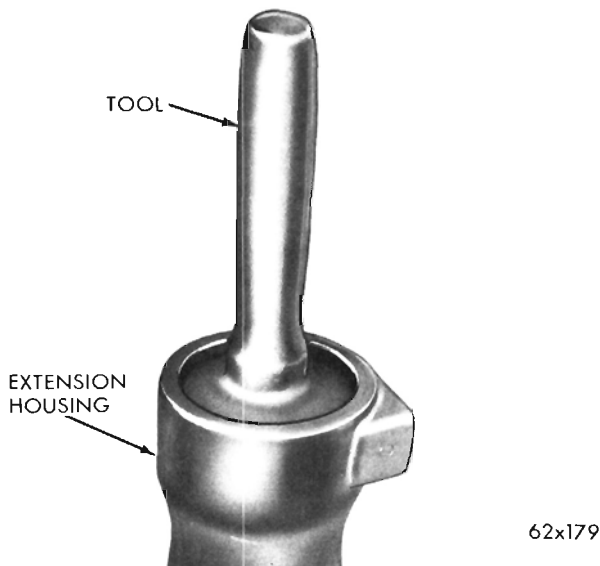

Fig. 50—Installing Output Shaft Bearing

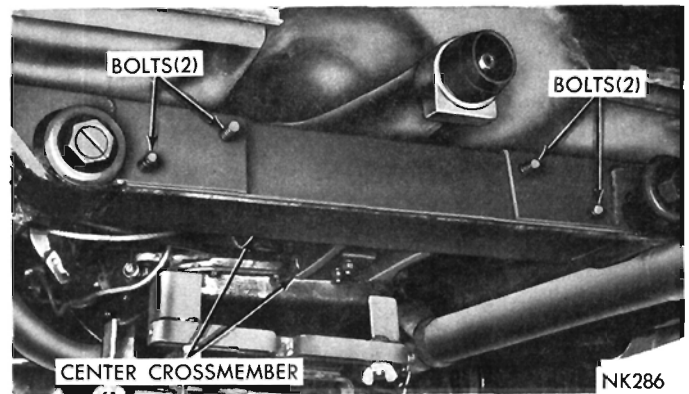

Fig. 51—Removing or Installing Center Crossmember (Fury Station Wagon)

EXTENSION HOUSING AND BEARING— A-727-A AND B

Removal

To remove the extension housing on the 121½ inch wheelbase Plymouth Station Wagon, it will be necessary to first remove the torsion bar rear anchor crossmember and rubber isolators. Refer to Group 2, "Torsion Bar Rubber Isolators," then remove the extension housing as follows:

(1) Disconnect propeller shaft at the rear universal joint. Carefully pull the shaft assembly out of the extension housing.

(2) Remove speedometer drive pinion and sleeve assembly (Fig. 43). Drain approximately two quarts of fluid from the transmission.

(3) Disconnect the parking lock cable. Refer to Page 58. Remove bolts securing the extension housing to the crossmember insulator. Raise the transmission slightly with service jack, Tool C-3203A. Tap out the four long bolts and remove the center crossmember (Fig. 51).

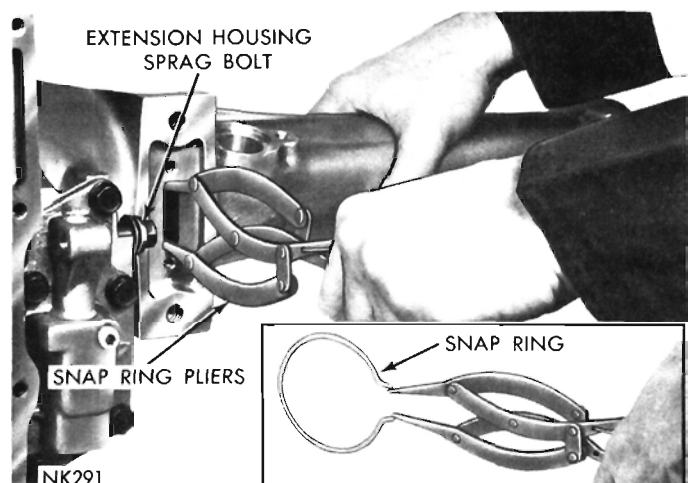
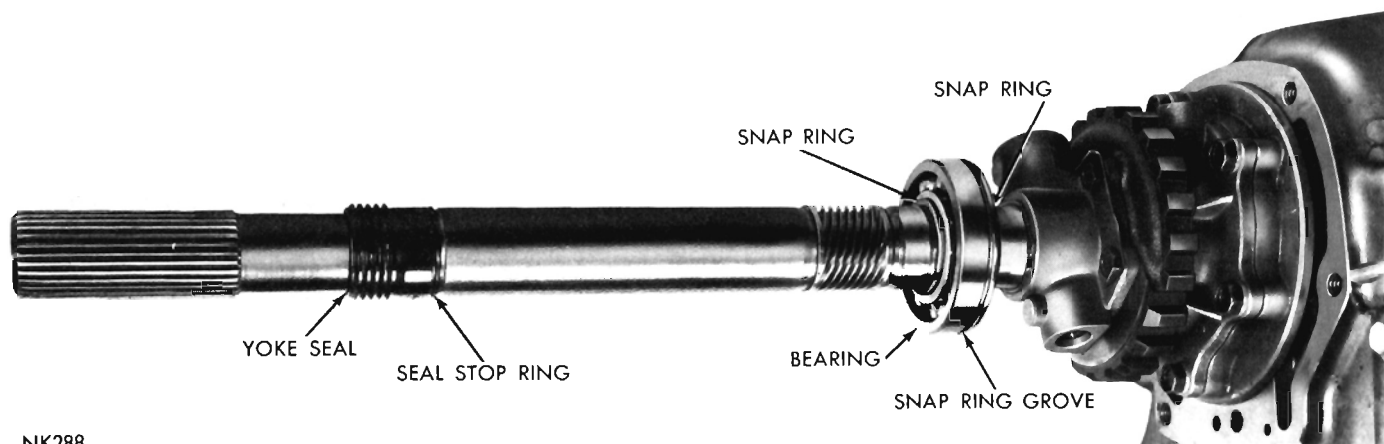

Fig. 52—Removing or Installing Extension Housing



NK288

Fig. 53—Output Shaft Bearing and Yoke Seal

(4) Remove the extension housing to transmission bolts, **do not remove the long bolt from the extension housing as it supports the parking sprag.**

(5) Remove two screws, plate and gasket from the bottom of the extension housing mounting pad. Spread the large snap ring from the output shaft bearing with Tool C-3301 (Fig. 52). With the snap ring spread as far as possible, carefully tap the extension housing off the output shaft and bearing.

NOTE: On some models, disconnect the steering center link at the idler arm so the transmission can be lowered far enough to permit extension housing removal.

Bearing Replacement

(1) Carefully slide the U-joint yoke seal (Fig. 53) off the output shaft. Unwind and slide seal stop ring off the shaft.

(2) Remove the output shaft bearing rear snap ring. Wipe the output shaft splines clean and dry, then wrap the splines with 3 or 4 layers of masking tape to protect the extension housing bushing during output shaft bearing removal.

(3) Temporarily reinstall the extension housing to provide a means of removing the output shaft bearing. Spread the large snap ring in the housing as far as possible with Tool C-3301 (Fig. 52). Carefully tap the housing into place, then release the snap ring. Make sure the snap ring is fully seated in the outer race ring groove of the bearing.

(4) Using a plastic or rawhide mallet, remove the extension housing and bearing assembly by striking the square boss rearward on the bottom rear end of the extension housing. Spread the large snap ring and remove the bearing from the housing. Remove the bearing front snap ring from the output shaft.

(5) Install a snap ring in the innermost groove on

the output shaft. Install a new bearing on the shaft with its outer race ring groove toward the front (Fig. 53). Press or tap the bearing tight against the front snap ring, then install the rear snap ring.

(6) Unwind and slide the yoke seal stop ring into place on the shaft. Install the seal with lips of seal toward the rear.

Installation

(1) Place a new extension housing gasket on the transmission case. Position the output shaft bearing retaining snap ring in the extension housing. Spread the snap ring as far as possible, then carefully tap the extension housing into place. **Make sure the snap ring is fully seated in the bearing groove.**

(2) Install the gasket, plate and two screws on the bottom of the extension housing mounting pad.

(3) Install and tighten extension housing bolts to 24 foot-pounds torque.

(4) Install the crossmember, insulator and spring assembly. Tighten the crossmember attaching bolts to 75 foot-pounds torque. Lower the transmission so the extension housing rests on, and is aligned with the insulator. Install the insulator to extension housing bolts and tighten to 35 foot-pounds torque.

Plymouth Station Wagon, 121½" W.B.: Install the center crossmember and rear mount assembly. Install the four long bolts through the crossmember and place isolator assemblies over the bolts, install and tighten the retaining nuts to 50 foot-pounds torque. Install the extension housing to rear mount insulator bolts and tighten to 35 foot-pounds torque. Refer to Group 2 and reinstall the torsion bar rear anchor crossmember and rubber isolators as outlined in "Torsion Bar Rubber Isolator."

(5) Install the speedometer pinion and cable. Install the propeller shaft assembly.

(6) Install and adjust the parking lock cable. Refer to Page 58.

(7) Add fluid to the transmission to bring up to the proper level. Refer to Page 49.

GOVERNOR

Removal

(1) Remove the extension housing. Refer to Page 70 or 71.

(2) Using a screw driver carefully pry the snap ring from the weight end of the governor valve shaft (Fig. 54). Slide the valve and shaft assembly out of governor body.

(3) Remove the large snap ring from weight end of the governor body, lift out the governor weight assembly.

(4) Remove the snap ring from inside the governor weight, remove inner weight and spring from the outer weight. Figure 55 shows a disassembled view of the governor assembly.

(5) Remove the snap ring from behind the governor body, then slide the governor and support assembly off the output shaft. If necessary remove the four bolts and separate governor body from the support.

Cleaning and Inspection

The primary cause of the governor operating failure is due to a sticking governor valve or weights. Rough surfaces may be removed with crocus cloth. Thoroughly clean all parts in clean solvent and inspect for free movement before assembly.

Installation

(1) Assemble the governor body to the support (if disassembled) and tighten bolts finger tight. Make sure oil passage of the governor body aligns with passage in the support.

(2) Position the support and governor assembly on the output shaft. Align the assembly so the governor valve shaft hole in the governor body aligns with the

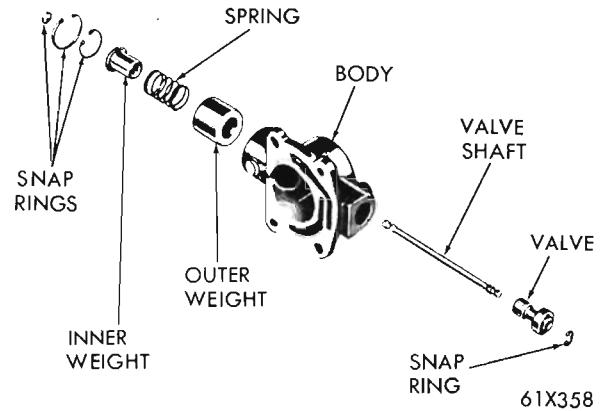

Fig. 55—Governor Assembly (Disassembled)

hole in the output shaft, then slide the assembly into place. Install snap ring behind the governor body (Fig. 54). Tighten the body to support bolts to 100 inch-pounds torque. Bend ends of lock straps over the bolt heads.

(3) Assemble the governor weights and spring, and secure with snap ring inside of the large governor weight. Place the weight assembly in the governor body and install snap ring.

(4) Place the governor valve on the valve shaft, insert the assembly into the body and through the governor weights. Install the valve shaft retaining snap ring. Inspect the valve and weight assembly for free movement after installation.

(5) Install the extension housing, transmission flange and connect the propeller shaft.

(6) Connect and adjust the parking lock cable. Refer to Page 58.

REAR OIL PUMP

Removal

(1) Remove the extension housing. Refer to Page 70 or 71.

(2) Remove the governor and support. Refer to Page 73.

(3) Unscrew the rear oil pump cover retaining bolts and remove the cover.

(4) The oil pump inner rotor is keyed to the output shaft by a small ball, therefore, use care in sliding out the inner rotor so as not to lose the ball (Fig. 56). Remove the outer rotor from the pump body.

NOTE: If the rear oil pump body requires replacement, it will be necessary to disassemble the transmission as the pump body must be driven rearward out of the case with a wood block.

Inspection

Inspect the oil pump body and cover machined sur-

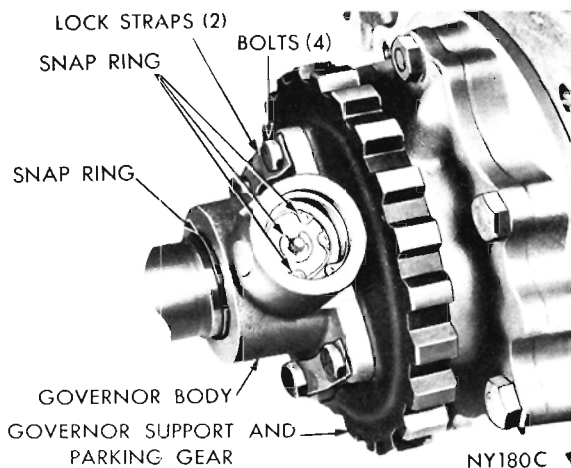
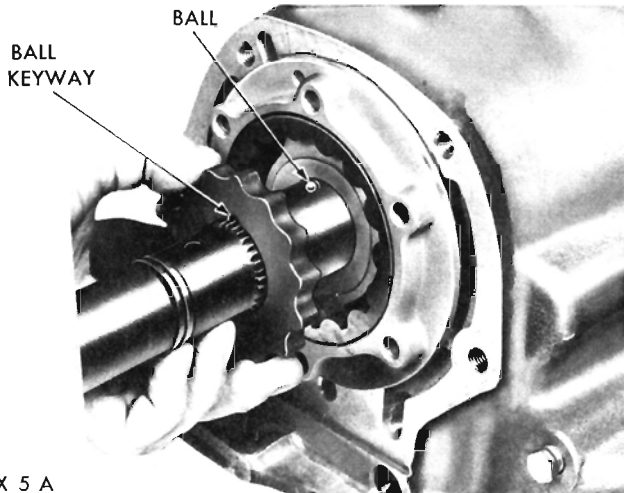

Fig. 54—Governor Shaft and Weight Snap Rings



62 X 5 A

Fig. 56—Removing or Installing Rear Oil Pump Inner Rotor

faces for nicks and burrs. Inspect the rotors for scoring or pitting. With the gears cleaned and installed in the pump body, place a straight edge across the face of rotors and pump body. Using a feeler gauge, measure the clearance between the straight edge and face of the rotors. Clearance limits are from .0015 to .003 inch.

Installation

- (1) Place the outer rotor in the pump body.
- (2) Turn the output shaft so the inner rotor driving ball pocket is up. Install the ball and slide the inner rotor on the output shaft in alignment with the ball (Fig. 56).
- (3) Install the oil pump cover with the retaining bolts threaded in a few turns. Slide the aligning fixture Tool C-3864 (A-727-A and B) or Tool C-3762 (A-904-G and A-904-LA) all the way in until it bottoms against the rotors (Fig. 57), then retighten the cover

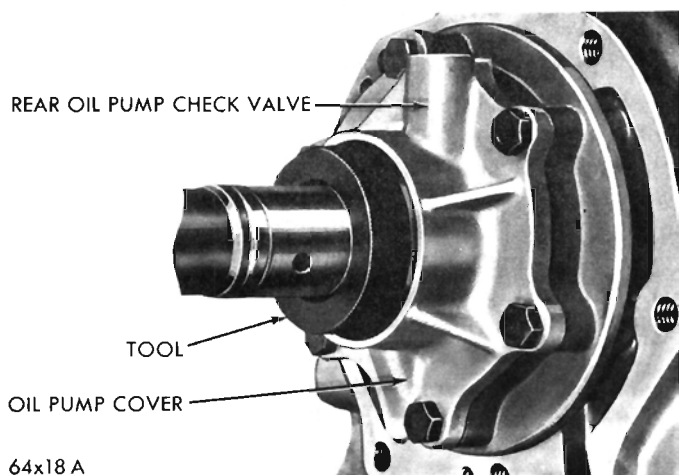

64x18 A

Fig. 57—Aligning Rear Oil Pump Cover

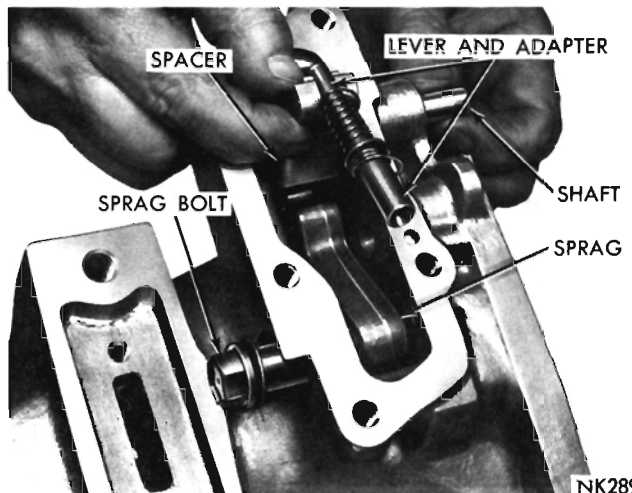

NK289

Fig. 58—Removing or Installing Parking Lock Lever and Cable Adapter

bolts evenly to 140 inch-pounds torque.

- (4) Install the governor and support. Refer to Page 73.
- (5) Install the extension housing, transmission flange and connect the propeller shaft.
- (6) Connect the parking lock cable.

PARKING LOCK COMPONENTS

Removal

- (1) Remove the extension housing. See Pages 70 or 71.
- (2) To replace the parking lock support gear, refer to Page 73.
- (3) Remove the parking lock cable adapter cover from the bottom of the extension housing.
- (4) Remove the plug from the extension housing, slide out the shaft to remove the parking lock lever, spacer and cable adapter (Fig. 58). Replace the adapter spring if it is distorted.

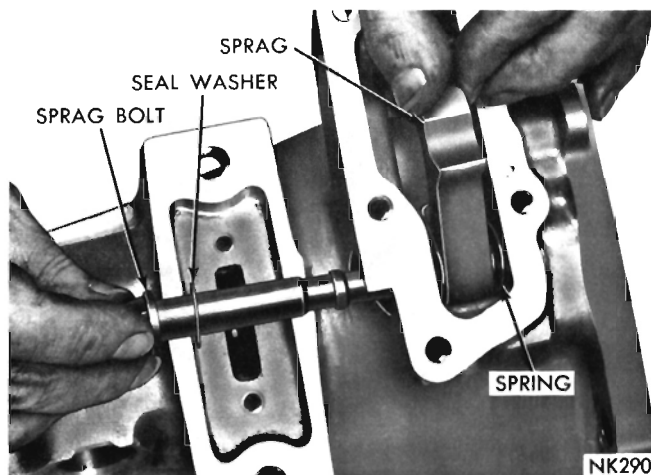

NK290

Fig. 59—Removing or Installing Parking Sprag

(5) Slide the bolt out of the housing to remove the parking sprag and spring (Fig. 59).

Installation

(1) Position the sprag and spring in the housing and insert the bolt (Fig. 59). Make sure the square lug on the sprag is toward the gear and the spring is positioned so as to lift the sprag away from the parking gear.

(2) Position the lock lever, spacer and cable adapter assembly in the extension housing and install the lever shaft (Fig. 58). The lever roller must be on top of the sprag so as to push it into engagement with the support gear. Install and tighten the plug to 150 inch-pounds torque.

(3) Insert a small punch through the cable opening in the adapter cover and into end of the adapter. Carefully lower the cover into position, feeding the adapter into the cable opening in the cover. Install the cover retaining screws and tighten to 150 inch-pounds torque.

(4) Install the extension housing, transmission flange and connect the propeller shaft.

(5) Connect and adjust the parking lock cable. Refer to Page 58.

VALVE BODY ASSEMBLY AND ACCUMULATOR PISTON

Removal

(1) Raise the vehicle on a hoist.

(2) Loosen the oil pan bolts, tap the pan to break it loose allowing the fluid to drain, then remove the oil pan.

(3) Loosen the clamp bolt and lift the throttle lever and washer off the transmission throttle lever shaft.

(4) Disconnect the gearshift control cable. Refer to Page 57. Shift the valve body manual lever to expose the E-clip securing the cable adapter to the lever (Fig. 30). Remove the E-clip and disengage the cable

adapter from the manual lever.

(5) Place a drain pan under the transmission, then remove the ten hex-head valve body to transmission case bolts. Hold the valve body in position while removing the bolts.

(6) Lower the valve body assembly down out of the transmission, being careful not to cock the throttle lever shaft in the case hole or lose the accumulator spring.

(7) Withdraw the accumulator piston from the transmission case. Inspect the piston for scoring, and the rings for wear or breakage. Replace as required.

NOTE: Servicing the valve body assembly is outlined on Page 81.

Installation

(1) Clean the mating surfaces and inspect for burrs on both the transmission case and valve body steel plate.

(2) Install the accumulator piston in the transmission case.

(3) Position the accumulator spring on the valve body.

(4) Carefully position the valve body assembly in the transmission case, install the retaining bolts and tighten finger tight. With the neutral starting switch installed, place the manual valve in the neutral position. Shift the valve body if necessary to center the neutral finger over the neutral switch plunger. Snug the bolts down evenly, then tighten to 100 inch-pounds torque.

(5) Connect the control cable adapter to the valve body manual lever and install the retaining E-clip. Connect the gearshift control cable. Refer to Page 57.

(6) Install the seal, flat washer and throttle lever on the throttle shaft. Tighten the clamping bolt. Inspect the throttle lever for looseness by forcing it in both directions.

(7) Install the oil pan, using a new gasket.

(8) Add fluid to the transmission to bring it up to proper level. Refer to Page 49.

TRANSMISSION AND CONVERTER

TORQUEFLITE A-904-G, A-904-LA, A-727-A AND B

Removal

CAUTION: The transmission and converter must be removed as an assembly; otherwise, the converter drive plate, front pump bushing, and oil seal will be damaged. The drive plate will not support a load; therefore, none of the weight of the transmission should be allowed to rest on the plate during removal.

To remove the A-727-A and B transmission on the

121½ inch wheelbase Plymouth Station Wagon, it will be necessary to first remove the torsion bar rear anchor crossmember and rubber isolators. Refer to Group 2, "Torsion Bar Rubber Isolators," then remove the transmission as follows:

(1) Connect a remote control starter switch, Tool C-763 to the starter solenoid and position the switch so the engine can be rotated from under the vehicle.

(2) Disconnect the high tension wire from the distributor cap. **Place the selector lever in the PARK position.**

(3) Remove the cover plate from in front of the

converter assembly to provide access to the converter drain plug and mounting bolts.

(4) Rotate the engine with the remote control switch to bring the drain plug to "6 o'clock" position. Drain the torque converter and transmission.

(5) Mark the converter and drive plate to aid in re-assembly. The crankshaft flange bolt circle, the inner and outer circle of holes in the drive plate, and the four tapped holes in the front face of the converter all have one hole offset so these parts will be installed in the original position. This maintains the balance of the engine and converter.

(6) Rotate the engine with the remote control switch to locate two converter to drive plate bolts at "5 and 7 o'clock" positions. Remove the two bolts, rotate the engine with switch and remove the other two bolts.

CAUTION: Do not rotate the converter or drive plate by prying with a screw driver or similar tool as the drive plate might become distorted. Also, the starter should never be engaged if the drive plate is not attached to the converter with at least one bolt or if the transmission case to engine bolts have been loosened.

(7) Disconnect the negative (ground) cable from the battery.

(8) Remove the starting motor assembly.

(9) Disconnect the wire from the neutral starting switch.

(10) Remove the gearshift control cable to transmission adjusting wheel lock screw. Pull the control cable out of the transmission case as far as possible, back off the adjusting wheel a few turns if necessary.

(11) Insert a small screw driver above and slightly to the right of the control cable (Fig. 26). Disengage the cable adapter lock spring by pushing the screw driver handle to the right while pulling outward on the cable.

(12) Disconnect the throttle rod from the throttle lever on the transmission.

(13) Disconnect the oil cooler lines at the transmission and remove the oil filler tube.

(14) Remove the speedometer pinion and sleeve assembly from the transmission.

(15) Loosen the transmission parking lock cable clamp bolt where the cable enters the cover (Fig. 27). Tap the end of the clamp bolt lightly to release its hold on the cable. Remove the housing cover lower plug. Insert a screw driver through the hole, then gently exert pressure against the projecting portion of the cable lock-spring and withdraw the lock cable.

(16) **A-904-G and A-904-LA:** Disconnect the front universal joint and secure the propeller shaft out of the way.

A-727-A and B: Disconnect propeller shaft at the

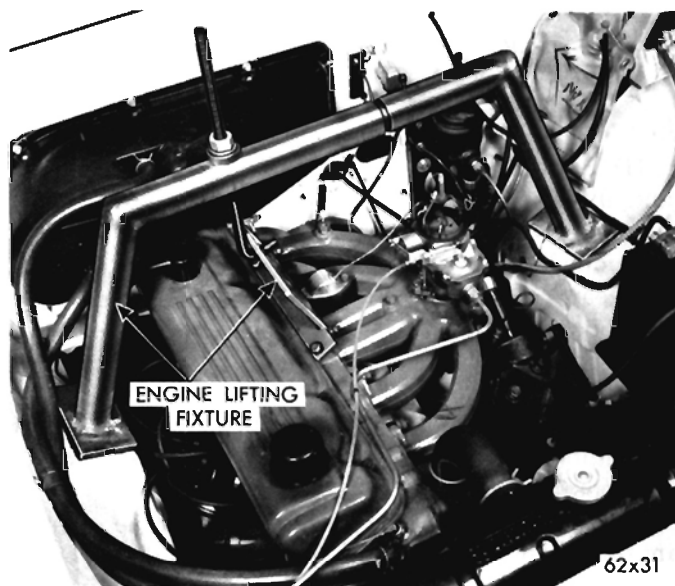

Fig. 60—Engine Lifting Fixture (6-Cyl. Engine)

rear universal joint. Carefully pull the shaft assembly out of extension housing.

(17) Remove the two bolts securing the extension housing to the crossmember insulator.

(18) Install an engine support fixture, Tool C-3487 (8 cyl. engine) or Tool C-3809 (6 cyl. engine) and raise the engine slightly (Fig. 60 or 61).

(19) Remove the crossmember attaching bolts and remove the crossmember, insulator and spring assembly.

(20) Place a transmission service jack under the transmission to support the assembly.

(21) Attach a small "C" clamp to edge of the bell housing to hold the converter in place during removal of the transmission.

(22) Remove the bell housing retaining bolts. Carefully work the transmission rearward off the engine block dowels and disengage the converter hub from the end of the crankshaft.

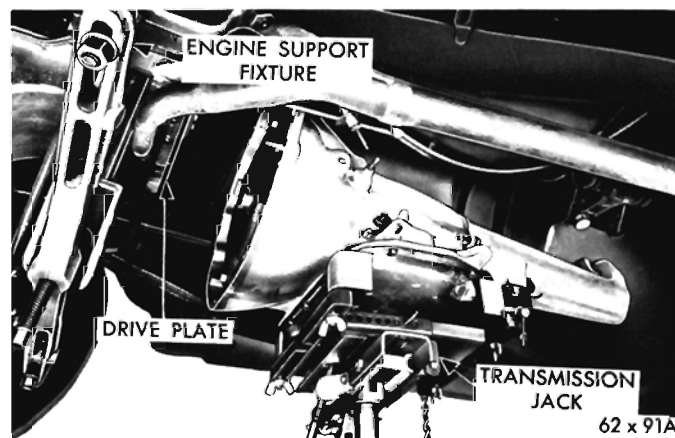

Fig. 61—Engine Lifting Fixture (8-Cyl. Engine)

(23) Lower the transmission jack and remove the transmission and converter assembly.

(24) To remove the converter assembly, remove the "C" clamp from the edge of the bell housing, then carefully slide the assembly out of the transmission.

STARTER RING GEAR REPLACEMENT

The starter ring gear is mounted directly on the outer diameter of the torque converter front cover. With the torque converter removed from the vehicle, replacement of the gear is as follows:

Removing Ring Gear

(1) Cut through the weld material at the rear side of ring gear with a hack saw or grinding wheel (Fig. 62). Be careful not to cut or grind into the front cover stamping.

(2) Scribe a heavy line on the front cover next to the front face of the ring gear to aid in locating the new gear.

(3) Support the converter with the four lug faces resting on blocks of wood. **The converter must not rest on the front cover hub during this operation.** Using a blunt chisel or drift and hammer, tap downward on the ring gear near the welded areas to break any remaining weld material (Fig. 62). Tap around the ring gear until it comes off the converter.

(4) Smooth off the weld areas on the cover with a file.

Installing Ring Gear

Any of the following methods may be used to heat and expand the starter ring gear for installation on the converter:

Oven: Place the ring gear in Oven C-794 and set the temperature at 200 degrees F. Allow the ring gear to remain in the oven for 15 to 20 minutes.

Boiling Water: Place the ring gear in a shallow con-

tainer, add water, and heat for approximately eight minutes after the water has come to a boil.

Steam: Place the ring gear on a flat surface and direct a steam flow around the gear for approximately two minutes.

Flame: Place the ring gear squarely on a flat surface. Using a medium size tip, direct a slow flame evenly around the inner rim of the gear. **Do not apply flame to the gear teeth.** Place a few drops of water on the face of gear at intervals during the heating process. When the gear is hot enough to just boil the water, installation of the gear on the torque converter can be made.

(1) After the ring gear is expanded by heating, place the gear in position on the converter front cover. Tap the gear on the cover evenly with a plastic or rawhide mallet until the face of the gear is even with the scribed line (made during removal) on the front cover. Make sure the gear is even with the scribed line around the full circumference of the front cover.

(2) Reweld the ring gear to the torque converter front cover, being careful to place, as nearly as possible, the same amount of weld material in exactly the same location as was used in the original weld. This is necessary in order to maintain proper balance of the unit. Place the welds alternately on opposite sides of the converter to minimize distortion.

(3) The following suggestions are offered as an aid in making the weld:

a. **Do not gas weld.**

b. Use a D.C. welder that is set at straight polarity or an A.C. welder if the proper electrode is available.

c. Use a 1/8 inch diameter welding rod, and a welding current of 80 to 125 amps.

d. Direct the arc at the intersection of the gear and front cover from an angle of 45 degrees from the rear face of the gear.

(4) Inspect the gear teeth and remove all nicks where metal is raised, weld metal splatter, etc., in order to ensure quiet starter operation.

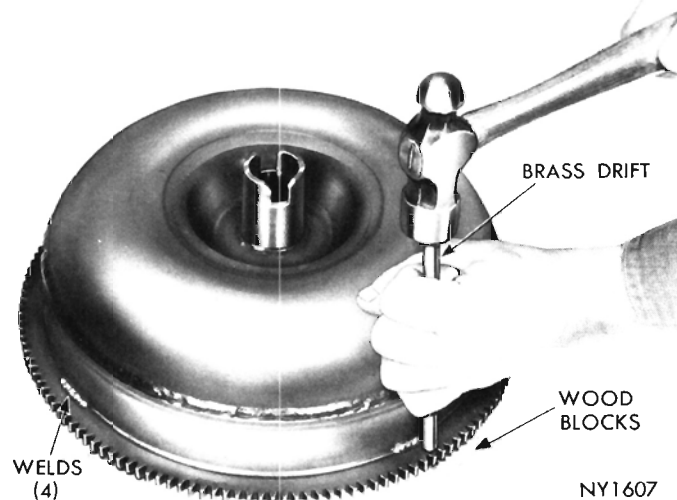

Fig. 62—Removing Starter Ring Gear

FLUSHING THE TORQUE CONVERTER

In the event that any part has failed in the transmission, the torque converter should be flushed to insure that fine metal particles are not later transferred back into the reconditioned transmission.

The torque converter **must be removed** from the vehicle for flushing, as the converter should never be rotated by the starter with the transmission removed.

(1) Place the torque converter in an upright position and pour two quarts of new clean solvent or kerosene into the converter through the impeller hub.

(2) Turn and shake the converter so as to swirl the solvent through the internal parts. Turning the turbine and stator with the transmission input and reaction shafts will aid in dislodging foreign material.

(3) Position the converter in its normal operating position with the drain plug at the lowest point. Remove the drain plug and drain the solvent. Rotate the turbine and stator, and shake the converter while draining to prevent dirt particles from settling.

(4) Repeat the flushing operation at least once, or as many times as required until the solvent or kerosene drained out is clear.

(5) After flushing, shake and rotate the converter several times with the drain plug out to remove any residual solvent and dirt. Flush any remaining solvent from the converter with two quarts of new transmission fluid. This will prevent any adverse effect the solvent may have on the transmission seals. Reinstall the drain plug and tighten to 14 foot-pounds torque.

FRONT PUMP OIL SEAL

Replacement

The front pump oil seal can be replaced without removing the front pump and reaction shaft support assembly from the transmission case.

NOTE: The vent shield is not used or required on the A-904-G and A-904-LA front pumps. See Figures 63 and 64.

(1) **A-904-G and A-904-LA:** Screw seal remover Tool C-3758 into the seal (Fig. 63), then tighten screw portion of the tool to withdraw the seal.

A-727-A and B: Using Tool C-3861, remove the seal in the same manner.

(2) **A-904-G and A-904-LA:** To install a new seal, place the seal in the opening of the pump housing (lip side facing inward). Using Tool C-3757, drive seal into housing until the tool bottoms (Fig. 64).

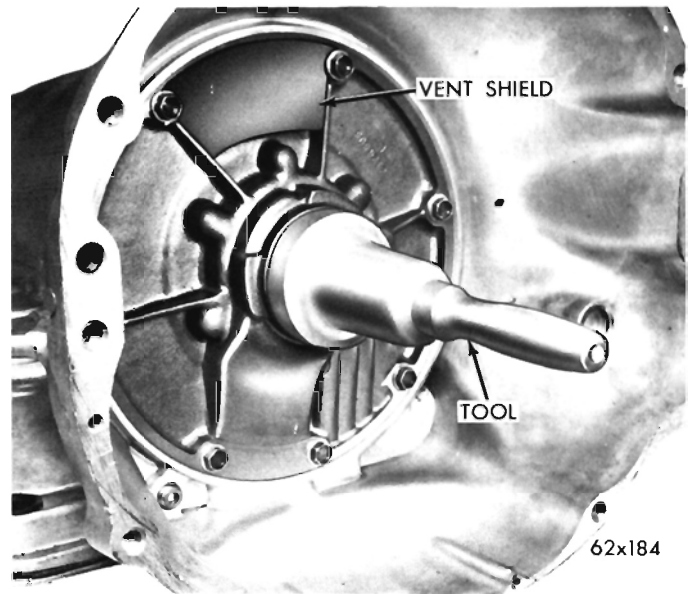

Fig. 64—Installing Front Pump Oil Seal

A-727-A and B: Using Tool C-3860, install the new seal in the same manner.

DISASSEMBLY—SUB-ASSEMBLY REMOVAL

Prior to removing any of the transmission sub-assemblies, plug all the openings and thoroughly clean the exterior of the unit, preferably by steam. Cleanliness through the entire disassembly and assembly cannot be over-emphasized. When disassembling, each part should be washed in a suitable solvent, then dried by compressed air. **Do not wipe parts with shop**

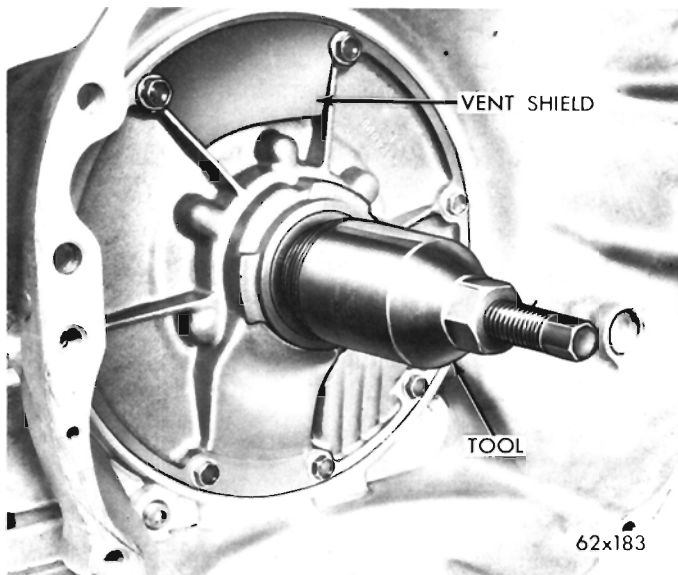

Fig. 63—Removing Front Pump Oil Seal

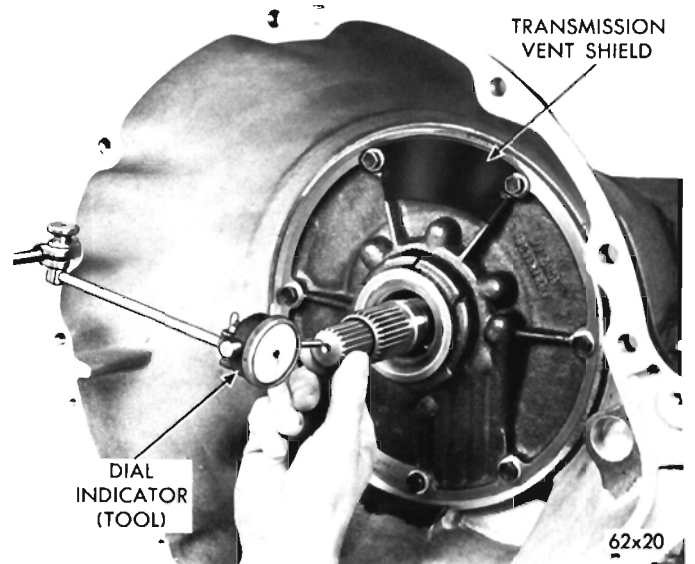

Fig. 65—Measuring Drive Train End Play

towels. All of the mating surfaces in the transmission are accurately machined; therefore, careful handling of parts must be exercised to avoid nicks or burrs.

Drive Train End Play

Measure the drive train end play before removal of the output shaft universal joint flange. This will usually indicate when a change in the thrust washer is required to properly adjust end play during assembly (except when major parts are replaced). **The thrust washer is located between the reaction shaft support and the front clutch retainer on the A-727-A and B transmissions. The thrust washer is located between the input and output shafts on the A-904-G and A-904-LA transmissions.**

(1) Attach a dial indicator to the transmission bell housing with its plunger seated against the end of the input shaft (Fig. 65). **Chuck** the input shaft in and out to obtain end play reading. End play specifications are: .023 to .089 for the A-904-G and A-904-LA transmissions, and .036 to .084 inch for the A-727-A and B transmissions.

(2) Record the indicator reading for reference when reassembling the transmission. Refer to Page 104.

Oil Pan

(1) **A-904-G:** Place the transmission assembly in repair stand, Tool-3750.

A-904-LA, A-727-A and B: Use adapter C-3882, with the repair stand to support these transmissions (Fig. 66).

If repair stand DD-1014 is available, fabricate two

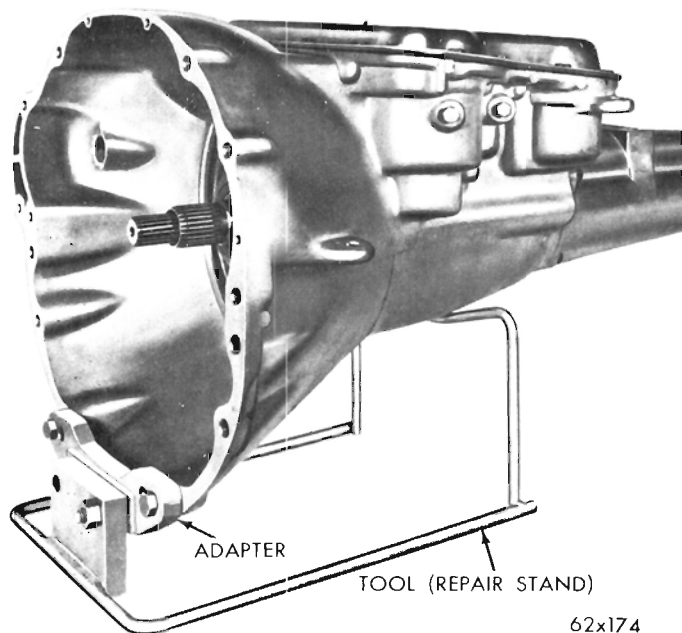

Fig. 66—Transmission Installed in Repair Stand

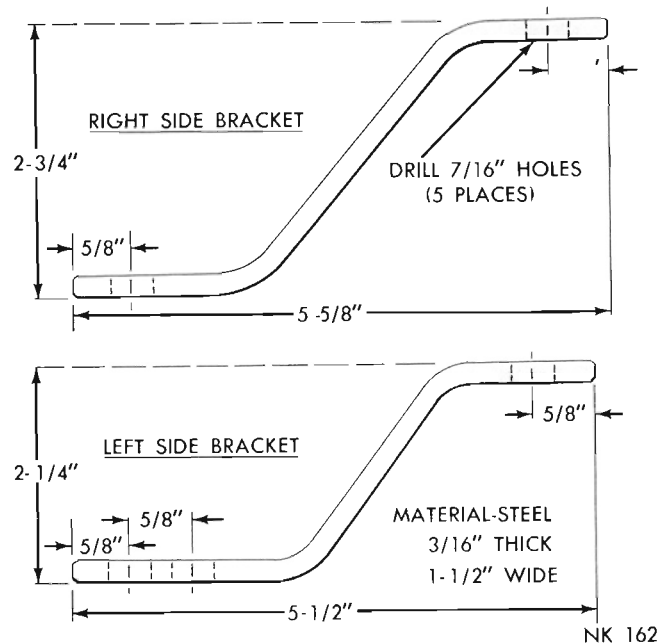

Fig. 67—Repair Stand Bracket Dimensions

attaching brackets (Fig. 67) and install transmission in the stand (Fig. 68), file out the $\frac{7}{16}$ holes if necessary to obtain bracket alignment. This stand provides easier disassembly and assembly as the transmission can be rotated as desired.

(2) Unscrew the oil pan bolts and remove the oil pan and gasket.

Valve Body Assembly

(1) Pry off E-clip and remove control cable adapter from the valve body manual lever (Fig. 30).

(2) Remove the ten hex-head valve body assembly to transmission case bolts. Hold the valve body in position while removing the bolts.

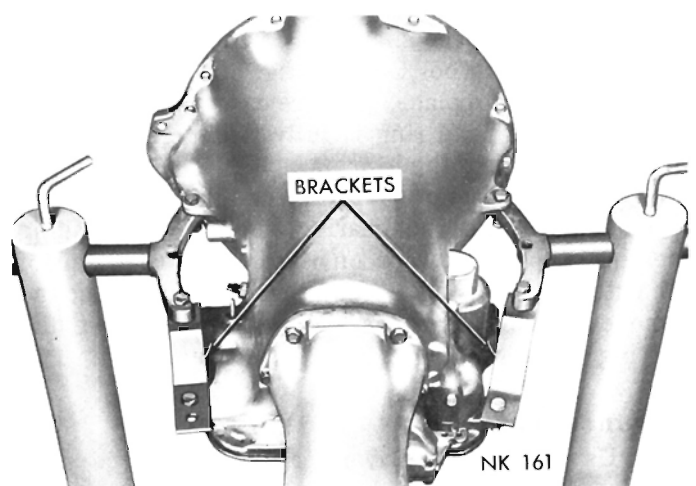

Fig. 68—Transmission Install in Repair Stand (Tool DD-1014)

(3) Lift the valve body assembly out of the transmission case, being careful not to cock the throttle lever shaft.

Accumulator Piston and Spring

(1) Lift the spring off the accumulator piston and withdraw the piston from the case.

Extension Housing

(1) **A-904-G and A-904-LA:** Hold the transmission flange with Tool C-3281, and remove the retaining nut and washer (Fig. 45). Slide the flange off the output shaft (Use puller, Tool C-452 if necessary).

(2) Remove the extension housing to transmission bolts, **do not remove the long bolt from the extension housing as it supports the parking sprag**. Tap the housing lightly with a soft mallet to break it loose from the transmission, then carefully remove the housing.

(1) **A-727-A and B:** Remove the extension housing to transmission bolts, **do not remove the long bolt from the extension housing as it supports the parking sprag**.

(2) Remove two screws, plate and gasket from the bottom of the extension housing mounting pad. Spread the large snap ring from the output shaft bearing with Tool C-3301 (Fig. 52). With the snap ring spread as far as possible, carefully tap the extension housing off the output shaft and bearing.

(3) Carefully slide the U-joint yoke seal (Fig. 53) off the output shaft. Unwind and slide seal stop ring off the shaft.

(4) Remove the output shaft bearing rear snap ring. Wipe the output shaft splines clean and dry, then wrap the splines with 3 or 4 layers of masking tape to protect the extension housing bushing during output shaft bearing removal.

(5) Temporary reinstall the extension housing to provide a means of removing the output shaft bearing. Spread the large snap ring in the housing as far as possible with Tool C-3301 (Fig. 52). Carefully tap the housing into place, then release the snap ring. Make sure the snap ring is fully seated in the outer race ring groove of the bearing.

(6) Using a plastic or rawhide mallet, remove the extension housing and bearing assembly by striking the square boss rearward on the bottom rear end of the extension housing. Spread the large snap ring and remove the bearing from the housing. Remove the bearing front snap ring from the output shaft.

Governor and Support

(1) Using a screw driver, carefully pry the snap ring from the weight end of the governor valve shaft (Fig. 54). Slide the valve and shaft assembly out of the governor body.

(2) Remove the snap ring from behind the governor body, then slide the governor body and support assembly off the output shaft.

Rear Oil Pump

(1) Unscrew the rear oil pump cover retaining bolts and remove the cover.

(2) The oil pump inner rotor is keyed to the output shaft by a small ball. Use care in sliding out the inner rotor so as not to lose the ball (Fig. 56). Remove the outer rotor from the pump body.

NOTE: If replacement of the rear oil pump body is required, drive it rearward out of the case with a wood block after the transmission has been disassembled.

Front Oil Pump and Reaction Shaft Support

(1) Remove the front oil pump housing retaining bolts.

(2) Tighten the front band adjusting screw until the band is tight on the front clutch retainer. This prevents the clutch retainer from coming out with the pump which might cause unnecessary damage to the clutches.

(3) Attach Tool C-3752 to the pump housing flange, as shown in Figure 69, install the tool in the threaded holes in the pump flange.

(4) Bump outward evenly on the two "knocker weights" to withdraw the oil pump and reaction shaft support assembly from the case.

Front Band and Front Clutch

(1) Loosen the front band adjuster, remove the band strut and slide the band out of the case.

(2) Slide the front clutch assembly out of the case.

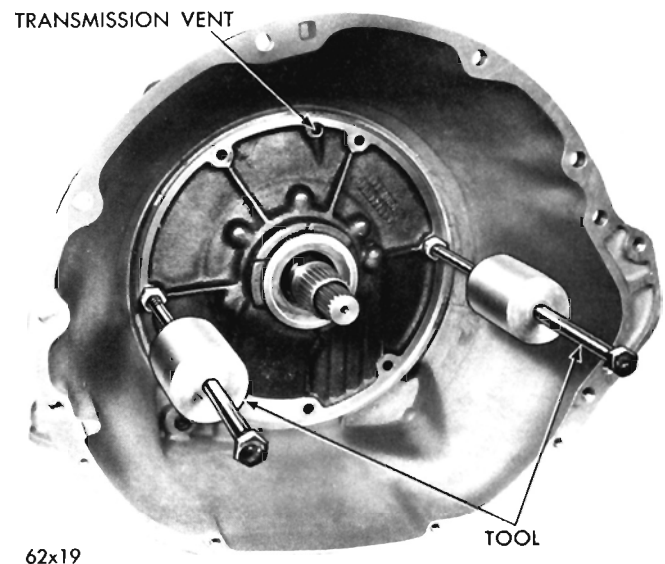

Fig. 69—Removing Front Oil Pump and Reaction Shaft Support Assembly

Input Shaft and Rear Clutch

(1) Grasp the input shaft, and slide the input shaft and rear clutch assembly out of the case.

NOTE: Be careful not to lose the thrust washer located between the rear end of input shaft and forward end of the output shaft.

Planetary Gear Assemblies, Sun Gear, Driving Shell

(1) While supporting the output shaft and driving shell, carefully slide the assembly forward and out through the case.

NOTE: Be very careful not to damage the ground surfaces on the output shaft during removal.

Rear Band and Low-Reverse Drum

(1) Remove the low-reverse drum, then loosen the rear band adjuster, remove the band strut and link, then remove the band from the case.

Overrunning Clutch

(1) Note the position of the overrunning clutch rollers and spring before disassembly to assist in re-assembly.

(2) Carefully slide out the clutch hub and remove the rollers and springs.

NOTE: If the overrunning clutch cam and/or roller spring retainer are found damaged or worn, refer to Page 100 for replacement procedures.

Kickdown Servo

(1) Compress the kickdown servo spring by using engine valve spring compressor, Tool C-3422, then remove the snap ring (Fig. 70).

(2) Remove the rod guide, springs and piston rod from the case. Be careful not to damage the piston rod or guide during removal.

(3) Insert Tool C-484 inside the piston and withdraw the piston from the transmission case.

Low and Reverse Servo

(1) Compress the low and reverse servo piston spring by using engine valve spring compressor, Tool C-3422, then remove the snap ring.

(2) Remove the spring retainer, spring, and servo piston and plug assembly from the case.

RECONDITION SUB-ASSEMBLIES

The following procedures cover the disassembly, inspection, repair, and assembly of each sub-assembly as removed from the transmission.

Heli-Coil inserts are recommended for repairing damaged, stripped or worn threads in aluminum parts. Refer to Page 49.

Pre-sized service bushings are available for replacement for most all bushings in the TorqueFlite transmission. The two bushings in the sun gear are not

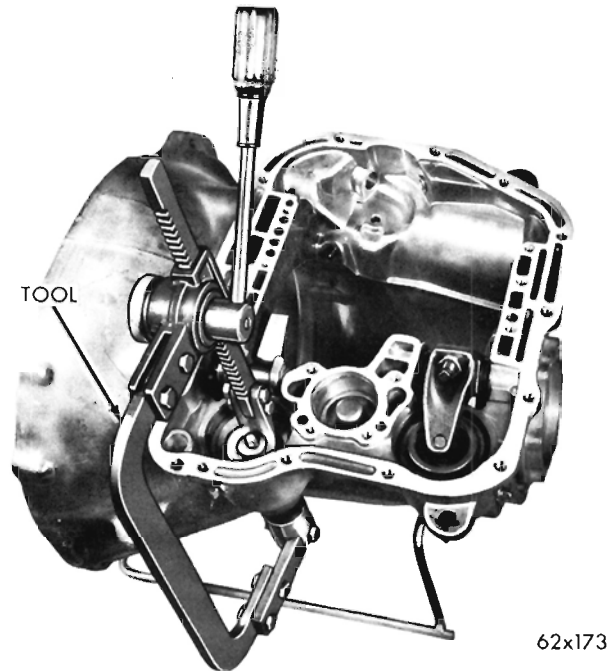

Fig. 70—Compressing Kickdown Servo Spring

serviced because of the low cost of the sun gear assembly. If the bushings are found worn or scored, they should be replaced as outlined in the following reconditioning procedures.

The bushing replacement tools listed by "SP" numbers are part of Tool Kit C-3887.

The use of crocus cloth is permissible where necessary, providing it is used carefully. When used on the valves, use extreme care to avoid rounding off the sharp edges. The sharp edge is vitally important to this type valve. Sharp edges prevent dirt and foreign matter from getting between the valve and body, thus reducing the possibilities of sticking. When it becomes necessary to recondition the transmission, and the vehicle has accumulated considerable mileage, install new seal rings on parts requiring their usage.

NOTE: Coat each part with Automatic Transmission Fluid Type "A" Suffix "A" during assembly.

VALVE BODY ASSEMBLY

Disassembly

CAUTION: Never clamp any portion of the valve body or transfer plate in a vise. Any slight distortion of the aluminum body or the transfer plate will result in sticking valves, excessive leakage or both. When removing or installing valves or plugs, slide them in or out carefully. Do not use force.

(1) Place the valve body assembly on repair stand, Tool C-3749 (Fig. 71). Remove three screws from the oil filter and lift off the filter and gasket.

(2) While holding the spring retainer firmly against

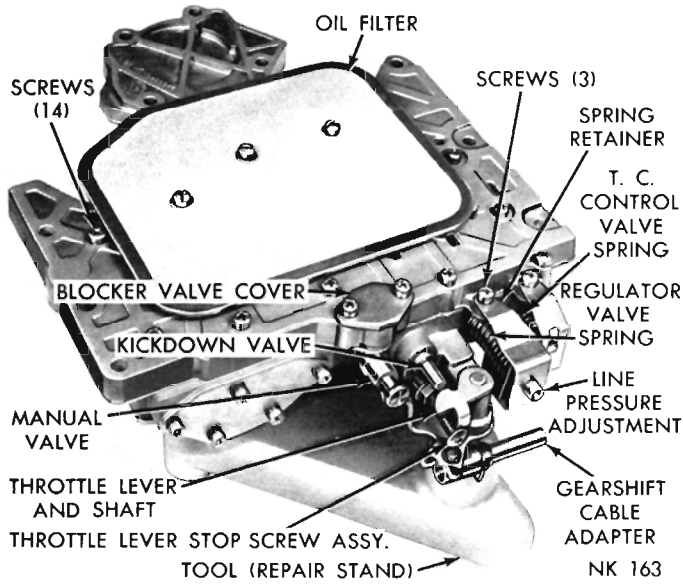

Fig. 71—Valve Body and Control Assembly

the spring force, remove the three bracket retaining screws (Fig. 71).

(3) Remove the spring retainer, torque converter control valve spring, and the regulator valve spring with line pressure adjusting screw assembly.

NOTE: Do not alter the setting of the line pressure adjusting screw and nut. The nut has an interference thread and does not turn easily on the screw.

(4) Slide the regulator valve out of the valve body. Slide the torque converter control valve out of the valve body.

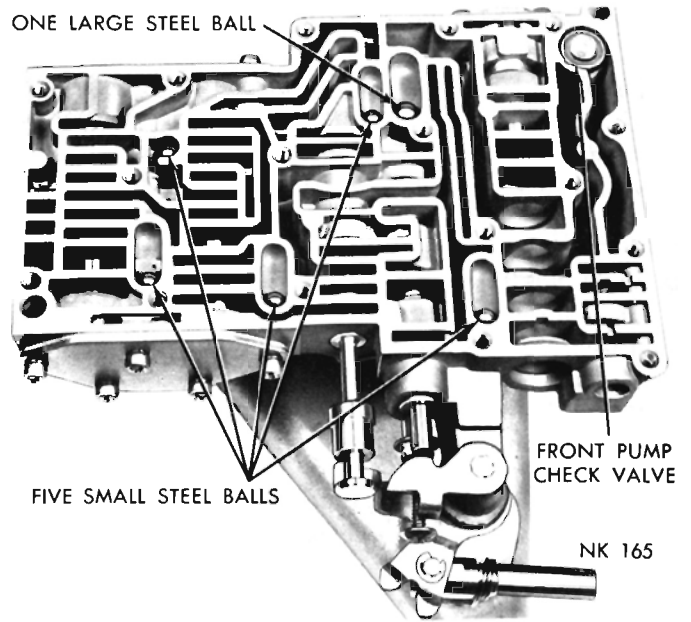

Fig. 73—Front Pump Check Valve and Steel Ball Locations

(5) Remove the 14 transfer plate retaining screws. Carefully lift the transfer plate and steel plate assembly off the valve body.

(6) Invert the transfer plate assembly and remove the stiffener plate. Remove remaining screws securing the steel plate to transfer plate, and carefully lift off the steel plate (Fig. 62). Remove the rear pump check valve and spring.

(7) Remove the reverse blocker valve cover and lift out the spring and valve.

(8) Note location of the six steel balls in the valve body, one is larger than the other five and is in the

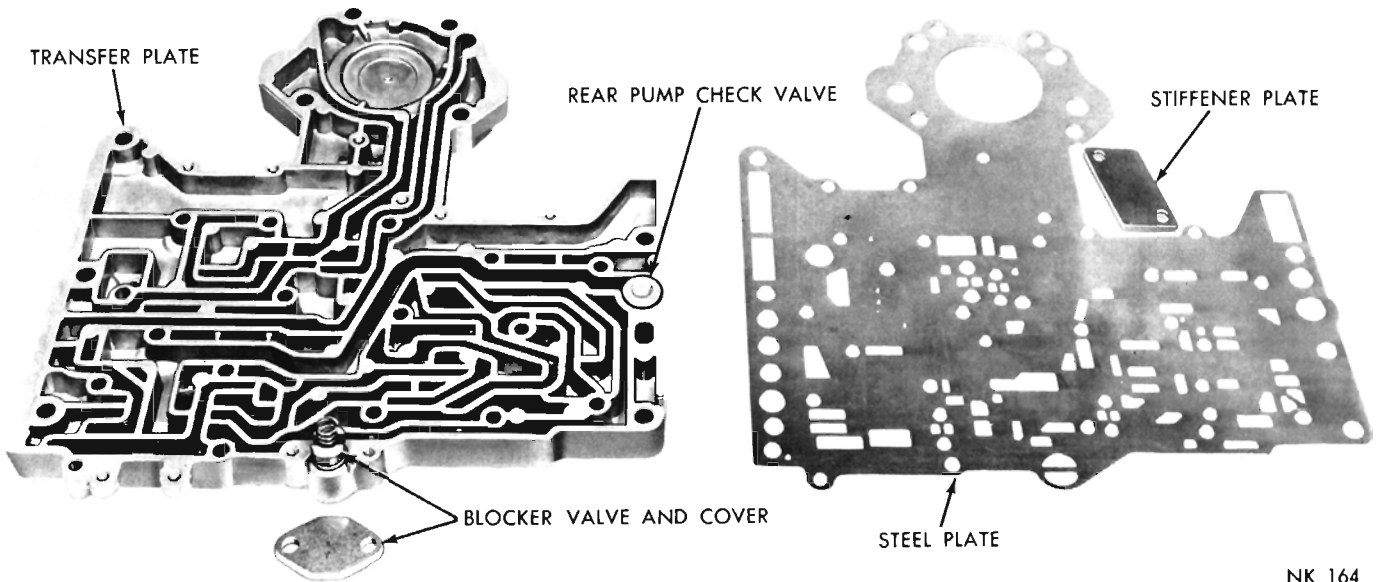

Fig. 72—Transfer and Steel Separator Plate Assembly (Disassembled)

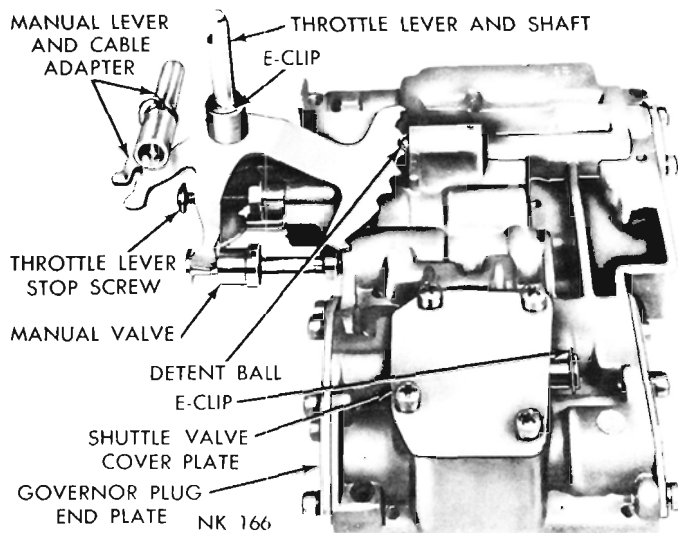

Fig. 74—Valve Body Controls (Assembled View)

larger chamber (Fig. 73). Remove the steel balls, front pump check valve and spring.

(9) Invert the valve body and lay it on a clean cloth or paper. Remove E-clip from the throttle lever shaft (Fig. 74). Remove any burrs from the shaft, then while holding the manual lever detent ball and spring in their bore with Tool C-3765 or similar tool, slide the manual lever off the throttle shaft. Remove the detent ball and spring.

(10) Remove the manual valve, carefully slide it out of valve body with a rotating motion.

(11) Remove the throttle lever and shaft from the valve body.

(12) Remove the shuttle valve cover plate (Fig. 74). Remove the E-clip from the exposed end of the shuttle valve.

(13) Remove the throttle lever stop screw assembly (Fig. 75), be careful not to disturb the setting any more than is necessary.

(14) Remove the kickdown detent, kickdown valve, throttle valve spring and the throttle valve (Fig. 75).

(15) Remove the governor plug end plate (Fig. 75). Tip up the valve body to allow the shuttle valve throttle plug, spring, shuttle valve, and the shift valve governor plugs to slide out into your hand.

Note the longer stem on the 1-2 shift valve plug as a means for identification.

(16) Remove the shift valve end plate (Fig. 76) and slide out the two springs and valves.

(17) Remove the regulator valve end plate. Slide the regulator valve line pressure plug, sleeve, and the regulator valve throttle pressure plug out of the valve body.

Cleaning and Inspection

Allow all parts to soak a few minutes in a suitable clean solvent. Wash thoroughly and blow dry with compressed air. Make sure all the passages are clean and free from obstructions.

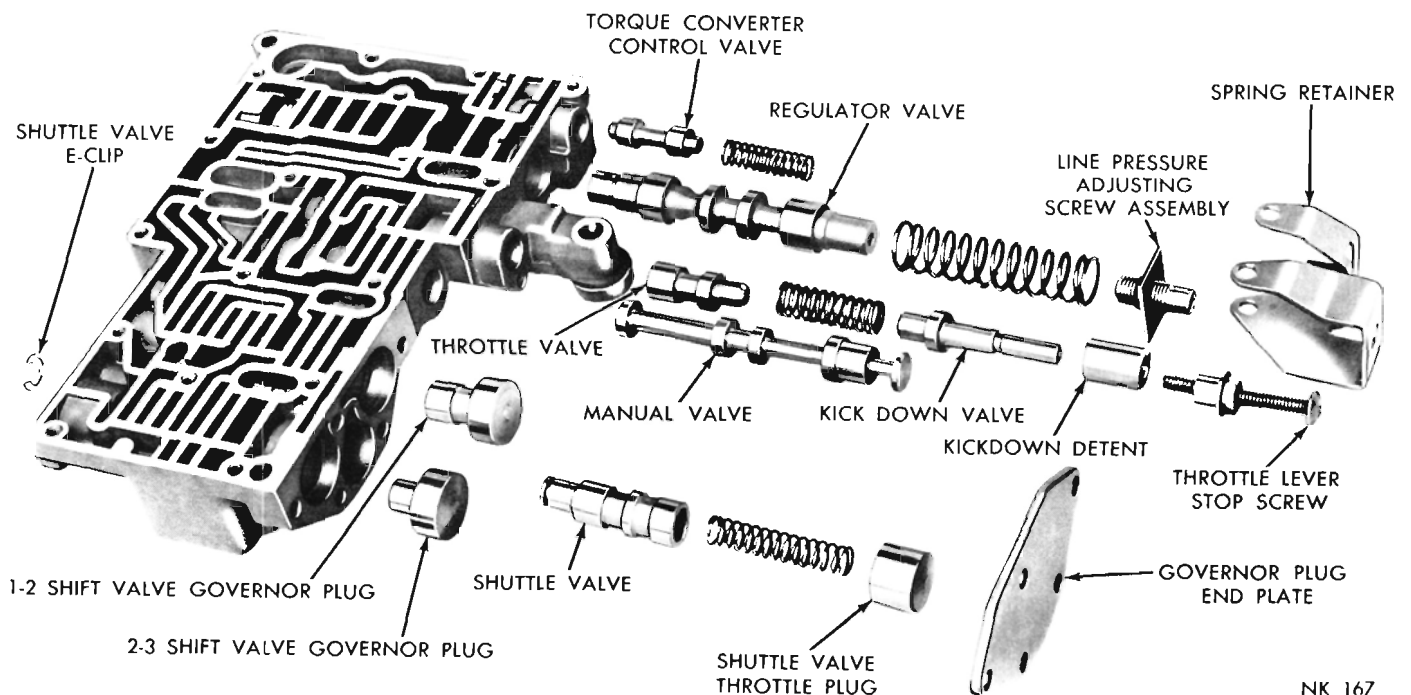

Fig. 75—Valve Body—Lever Side (Disassembled)

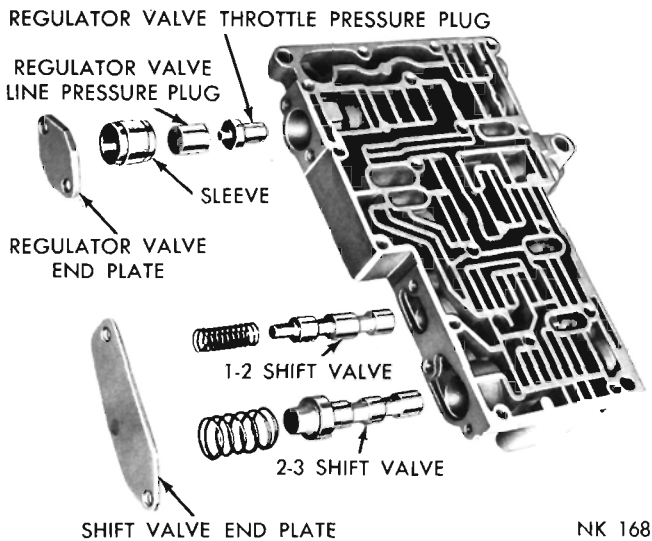

Fig. 76—Valve Body—Shift Valve Side
(Disassembled)

Inspect the manual and throttle valve operating levers and shafts for being bent, worn or loose. If a lever is loose on its shaft, it may be **silver soldered** only, or the lever and shaft assembly should be replaced. **Do not attempt to straighten bent levers.**

Inspect all mating surfaces for burrs, nicks and scratches. Minor blemishes may be removed with crocus cloth, using only a very light pressure. Using a straight edge, Tool C-3335, inspect all mating surfaces for warpage or distortion. Slight distortion may be corrected, using a surface plate. Make sure all metering holes in the steel plate are open. Using a pen light, inspect bores in the valve body for scores, scratches, pits and irregularities.

Inspect all valve springs for distortion and collapsed coils. Inspect all valves and plugs for burrs, nicks and scores. Small nicks and scores may be removed with crocus cloth, providing extreme care is taken not to round off the sharp edges. The sharpness of these edges is vitally important because it prevents foreign matter from lodging between the valve and the valve body, thus reducing the possibility of sticking. Inspect all valves and plugs for freedom of operation in the valve body bores. When bores, valves and plugs are clean and dry, the valves and plugs should fall freely in the bores.

NOTE: The valve body bores do not change dimensionally with use. Therefore, a valve body that was functioning properly when the vehicle was new, will operate correctly if it is properly and thoroughly cleaned. There is no need to replace the valve body unless it is damaged in handling.

Assembly

(1) Place the rear pump check valve and spring in the transfer plate (Fig. 72). Position the steel plate on

the transfer plate, and install four steel plate to transfer plate retaining screws. Make sure the bolt holes in the steel plate and transfer plate are aligned, then tighten screws evenly to 28 inch-pounds torque. Inspect the rear pump check valve for free movement in the transfer plate. Install the stiffener plate and tighten the retaining screws to 28 inch-pounds torque.

(2) Turn the transfer plate over and install the reverse blocker valve spring and valve (Fig. 72). Rotate the valve until it seats through the steel plate. Hold the valve down and install the blocker valve cover plate. Tighten the two remaining screws to 28 inch-pounds torque.

(3) Place the 1-2 and 2-3 shift valve governor plugs in their respective bores (Fig. 75). Install the shuttle valve, spring and shuttle valve throttle plug. Install the governor plug end plate and tighten the five retaining screws to 28 inch-pounds torque.

(4) Install E-clip on end of the shuttle valve (Fig. 75). Install the shuttle valve cover plate and tighten the four retaining screws to 28 inch-pounds torque.

(5) Install the 1-2 and 2-3 shift valves and springs (Fig. 76). Install the shift valve end plate and tighten the three retaining screws to 28 inch-pounds torque.

(6) Install the regulator valve throttle pressure plug, sleeve, and the line pressure plug (Fig. 76). Install the regulator valve end plate and tighten the two retaining screws to 28 inch-pounds torque.

(7) Install the throttle valve and spring (Fig. 75). Slide the kickdown detent and the kickdown valve (counterbore side of detent toward valve), then install the assembly in the valve body.

(8) Install the throttle lever stop screw (Fig. 75), and tighten the lock nut finger tight.

(9) Install the manual valve in the valve body (Fig. 75).

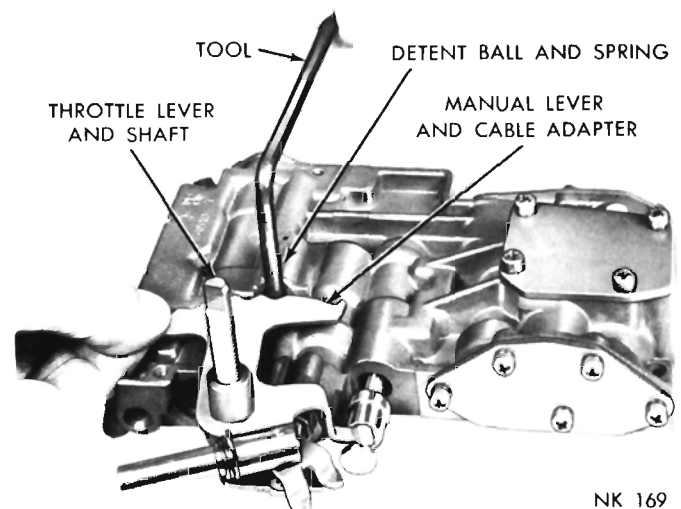

Fig. 77—Installing Detent Ball, Spring and Manual Lever

(10) Install the throttle lever and shaft on the valve body (Fig. 77). Insert the detent spring and ball in its bore in the valve body. Depress the ball and spring with Tool C-3765 or similar tool and slide the manual lever over the throttle shaft so that it engages the manual valve and detent ball. Install the retaining E-clip on the throttle shaft.

(11) Position the valve body assembly on the holding stand.

(12) Place the six steel balls in the valve body chambers with the large ball in the large chamber (Fig. 73). Place the front pump check valve and spring in the valve body.

(13) Position the transfer plate assembly on the valve body. Install the 14 retaining screws, starting at the center and working outward, tighten the screws to 28 inch-pounds torque.

(14) Install the torque converter valve and the regulator valve (Fig. 75).

(15) Position the torque converter valve spring and regulator valve spring over the ends of their respective valves. Place the line pressure adjusting screw assembly on the end of the regulator valve spring with long dimension of nut at right angles to the valve body (Fig. 71).

(16) Install the spring retainer, making sure the converter valve spring is engaged on the tang and position squarely in the retainer. Tighten the three retaining screws to 28 inch-pounds torque (Fig. 71).

NOTE: Measure and if necessary, align the spring retainer as described on Page 67.

(17) Install the oil filter and tighten the three retaining screws to 28 inch-pounds torque. **After the valve body has been serviced and completely assembled, adjust the throttle and line pressures, as outlined on Page 67. However, if pressures were satisfactory prior to disassembly, use the original settings.**

ACCUMULATOR PISTON AND SPRING

Inspection

Inspect the two seal rings for wear and make sure they turn freely in the piston grooves. It is not necessary to remove the rings unless conditions warrant. Inspect the piston for nicks, burrs, scores and wear. Inspect the piston bore in the case for scores or other damage. Inspect the piston spring for distortion. Replace parts as required.

EXTENSION HOUSING BEARING AND OIL SEAL—A-904-G AND A-904-LA

Replacement

(1) Pry or drive the oil seal out of the extension housing with a long blunt drift. Be sure not to mar the oil seal surface in the extension housing.

(2) Remove the bearing snap ring from the exten-

sion housing.

(3) Drive the bearing rearward out of the extension housing with Tool C-3275 (Fig. 49).

(4) Place a new bearing in opening of the extension housing. Using Tool C-3204, drive the bearing into the housing (Fig. 50). Install the bearing retaining snap ring.

(5) Place a new oil seal in opening of the extension housing (lip of seal facing inward). Using Tool C-3837, drive the seal into housing until tool bottoms (Fig. 47).

EXTENSION HOUSING BUSHING AND OIL SEAL—A-727-A AND B

Replacement

(1) Pry or drive the oil seal out of the extension housing with a long blunt drift. Be sure not to mar the oil seal surface in the housing.

(2) Press or drive out bushing with Tool C-3974 (Fig. 78).

(3) Slide a new bushing on the installing end of Tool C-3974. Align the oil hole in bushing with the oil slot in the housing, then press or drive the bushing into place (Fig. 78).

(4) Position a new seal in the opening of the extension housing and drive it into the housing with Tool C-3972 (Fig. 47).

PARKING SPRAG AND LEVER

Disassembly

(1) Remove the parking lock cable adapter cover

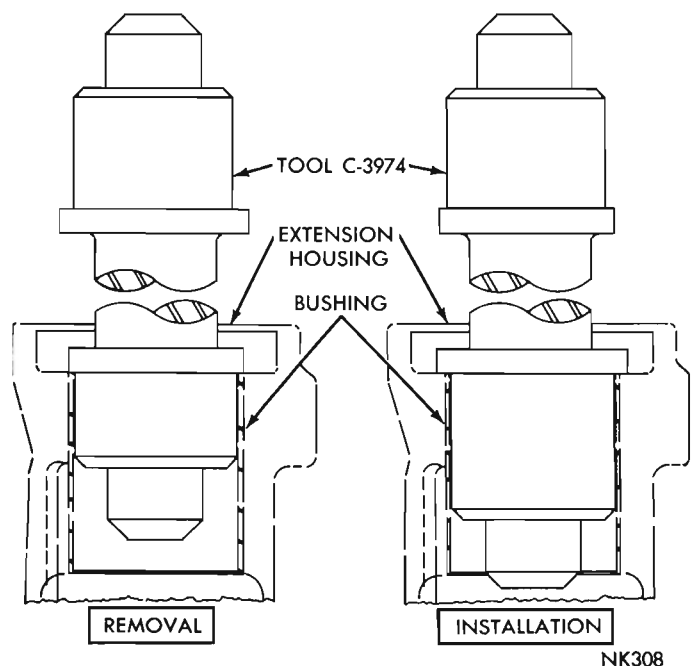

Fig. 78—Replacing Extension Housing Bushing

from the bottom of the extension housing.

(2) Remove the plug and slide the shaft out of the extension housing to remove the parking lock lever, adapter and spacer (Fig. 58).

(3) Slide the bolt out of the housing to remove the parking sprag and spring (Fig. 59).

Inspection

Inspect the sprag bolt and lever shaft for scores and free movement in the housing, and in sprag and lever. Inspect the roller for nicks, burrs, and free turning. Inspect the square lug on parking sprag for broken edges or other damage. Replace parts as required.

Assembly

(1) Position the parking sprag and spring in the housing and insert the bolt and washer gasket (Fig. 59). Make sure the square lug on the sprag is toward the support gear and the spring is positioned so as to lift the sprag away from the gear.

(2) Position the lock lever, adapter and spacer in the housing and install the lever shaft (Fig. 58). The lever roller must be on top of the sprag so as to push it into engagement with the gear.

(3) Place a new adapter cover gasket on the extension housing, then insert a small punch through cable opening in the adapter cover and into the end of the adapter. Carefully lower the cover into position, feeding the adapter into the cable opening in the cover. Install the cover retaining screws and tighten to 150 inch-pounds torque.

GOVERNOR AND SUPPORT

Disassembly

(1) Remove the large snap ring from the weight end of the governor body, lift out the weight assembly.

(2) Remove the snap ring from inside the governor weight, remove the inner weight and spring from the outer weight.

(3) If the lugs on the support gear are damaged, remove the four bolts and separate the support from the governor body.

Cleaning and Inspection

Figure 55 shows a disassembled view of the governor assembly.

Inspect all parts for burrs and wear. Inspect the inner weight for free movement in the outer weight, and outer weight for free movement in the governor body. Inspect the valve for free movement in the governor body. The weights and valve should fall freely in the bores when clean and dry. Rough surfaces may be removed with crocus cloth.

Inspect the governor weight spring for distortion. Inspect the lugs on the support gear for broken edges

or other damage. Thoroughly clean all the governor parts in clean solvent and test for free movement before assembly.

Assembly

(1) If the support was separated from the governor body, assemble and tighten the bolts finger tight. Make sure the oil passage of the governor body aligns with the passage in the support.

(2) Assemble the governor weights and spring, and secure with the snap ring inside of the large governor weight. Place the weight assembly in the governor body and install the snap ring.

REAR OIL PUMP

Inspection

Inspect the oil pump body and cover machined surfaces for nicks and burrs. Inspect the rotors for scoring or pitting. With the rotors cleaned and installed in the pump body, place a straight edge across the face of rotors and pump body. Use a feeler gauge to measure the clearance between the straight edge and face of the rotors. Clearance limits are from .0015 to .003 inch.

Rear Oil Pump Body Replacement

If replacement of the rear oil pump body is required, drive it rearward out of the case with a wood block and hammer. The following procedures must be followed when installing a new rear oil pump body or reinstalling the original pump body to prevent pump body distortion.

(1) Screw two pilot studs, Tool C-3288 into the case to guide the pump body during installation.

(2) Chill the pump body in cold water or with ice. Quickly position the body over the pilot studs, and drive it firmly into the case with a wood block and hammer. Remove the pilot studs.

FRONT OIL PUMP AND REACTION SHAFT SUPPORT—A-904-G AND A-904-LA

Disassembly

Figure 79 shows the front oil pump and reaction shaft support disassembled.

(1) Remove the bolts from the rear side of the reaction shaft support and lift the support off the oil pump.

(2) Remove the rubber seal ring from the front pump body flange.

(3) Drive out the oil seal with a blunt punch.

Inspection

Inspect interlocking seal rings (Fig. 79) on the reaction shaft support for wear or broken locks, make sure they turn freely in the grooves. Do not remove

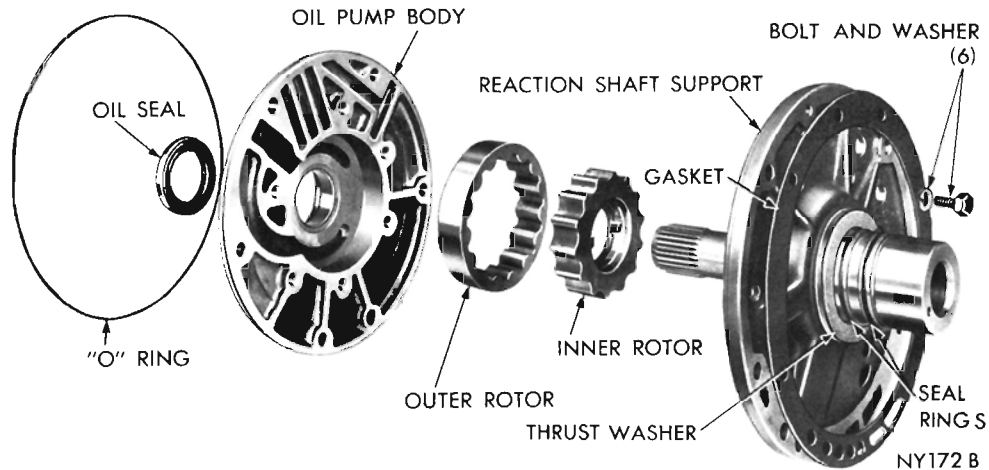

Fig. 79—Front Oil Pump and Reaction Shaft Support

rings unless conditions warrant. Inspect the front clutch piston retainer to reaction shaft support thrust washer for wear. Washer thickness should be .043 to .045 inch, replace if necessary. Inspect machined surfaces on the oil pump body and reaction shaft support for nicks and burrs. Inspect the pump body and reaction shaft support bushings for wear or scores. Inspect the oil pump rotors for scoring or pitting. With the rotors cleaned and installed in the pump body, place a straight edge across face of the rotors and pump body. Use a feeler gauge to measure the clearance between the straight edge and face of the rotors. Clearance limits are from .001 to .0025 inch. Also, measure the rotor tip clearance between the inner and outer rotor teeth. Clearance limits are from .007 to .012 inch.

Front Pump Bushing Replacement

- (1) Place the front pump housing (seal face down) on a smooth firm surface.
- (2) Place the removing head, Tool SP-3551 in the bushing and install the handle, Tool SP-3549 in the removing head (Fig. 80).
- (3) Drive the bushing straight down and out of the pump housing bore. Be careful not to cock the tool in the bore.
- (4) Position the new bushing on the installing head, Tool SP-3624.
- (5) With the pump housing on a smooth clean surface, start the bushing and installing head in the bushing bore. Install the handle, Tool SP-3549 in the installing head (Fig. 80).
- (6) Drive the bushing into the housing until the tool bottoms in the pump cavity. Be careful not to cock the tool during installation.
- (7) Stake the bushing in place by using a blunt

punch or similar tool (Fig. 81). A gentle tap at each stake slot location will suffice.

- (8) Using a narrow-bladed knife or similar tool, remove the high points or burrs around the staked area (Fig. 81). Do not use a file or similar tool that will remove more metal than is necessary.

Reaction Shaft Bushing Replacement

In case of a reaction shaft bushing failure, always inspect the support for wear from the input shaft seal ring lands. If worn or grooved, replace the sup-

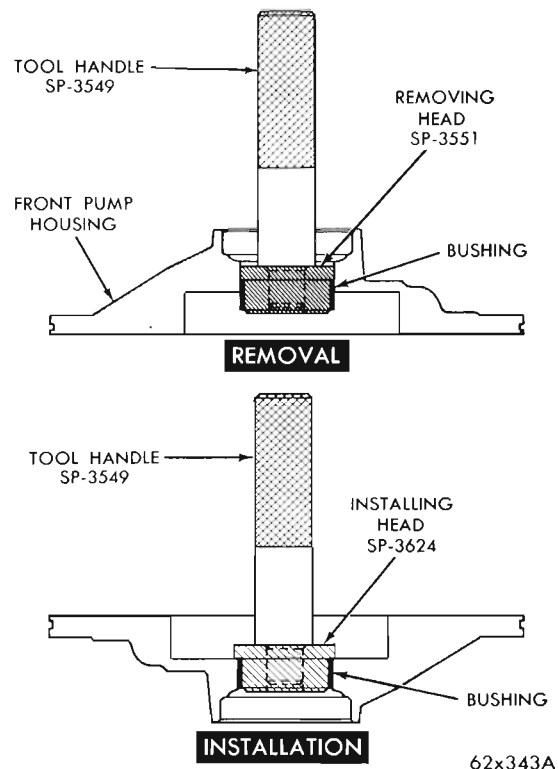

Fig. 80—Replacing Front Pump Bushing

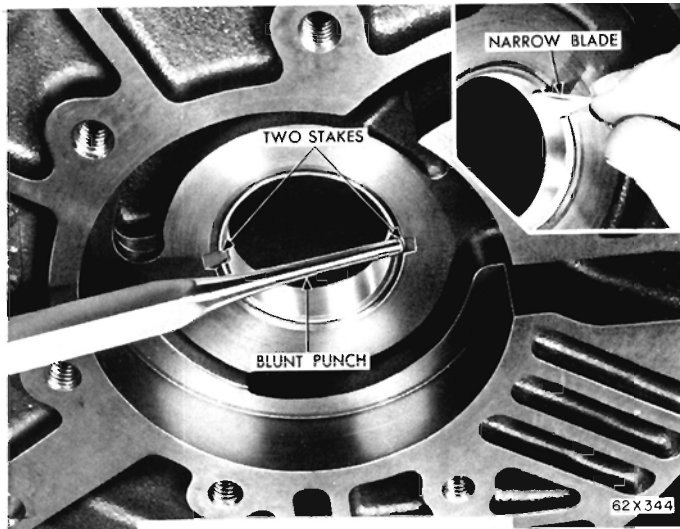

Fig. 81—Staking Front Pump Bushing

port assembly.

(1) Assemble the remover Tool SP-3631, the cup Tool SP-3633, and the hex nut Tool SP-1191 (Fig. 82).

CAUTION: Do not clamp any part of the reaction shaft or support in a vise.

(2) With the cup held firmly against the reaction shaft, thread the remover into the bushing as far as possible by hand.

(3) Using a wrench, screw the remover into the bushing 3 to 4 additional turns to firmly engage the threads in the bushing.

(4) Turn the hex nut down against the cup to pull the bushing from the reaction shaft. Thoroughly clean the reaction shaft to remove the chips made by the remover threads.

(5) Lightly grip the bushing in a vise or with pliers and back the tool out of the bushing. Be careful not to damage the threads on the bushing remover.

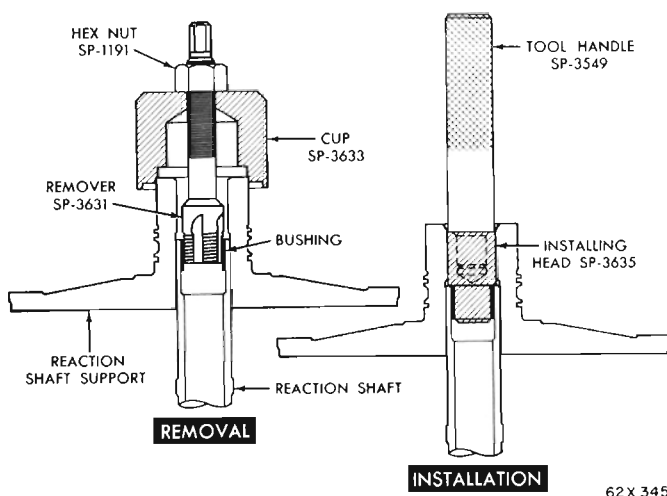

Fig. 82—Replacing Reaction Shaft Bushing

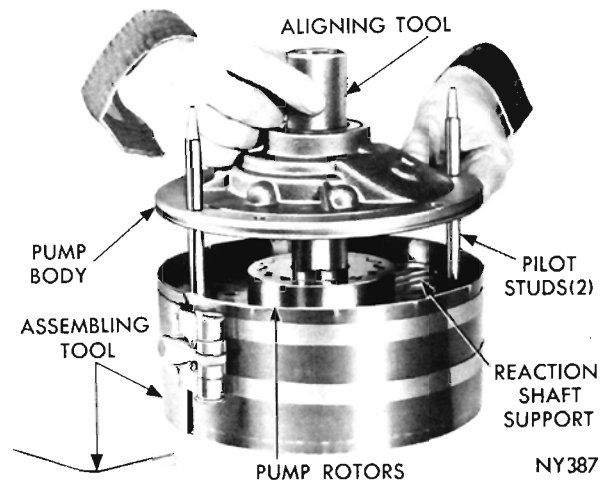

Fig. 83—Assembling Front Pump and Reaction Shaft Support

(6) Slide a new bushing on the installing head Tool SP-3635, and start them in the bore of the reaction shaft (Fig. 82).

(7) Support the reaction shaft upright on a clean smooth surface and install the handle Tool SP-3549 in the installing head. Drive the bushing into the shaft until the tool bottoms.

(8) Thoroughly clean the reaction shaft support assembly before installation.

Assembly

(1) Place the reaction shaft support in the assembling Tool C-3759, with hub of the support and tool resting on a smooth surface bench (Fig. 83). Screw two pilot studs, Tool C-3283 into threaded holes of the reaction shaft support flange.

(2) Assemble and place the rotors in center of the support (Fig. 83).

(3) Lower the pump body over the pilot studs, insert Tool C-3756 through the pump body and engage with the pump inner rotor. Rotate the rotors with the tool to enter the rotors in the pump body, then with the pump body firmly against the reaction shaft support, tighten the clamping tool securely.

(4) Invert the front pump and reaction shaft support assembly with the clamping tool intact. Install the support to pump body bolts and tighten to 125 inch-pounds torque. Remove the clamping tool, pilot studs and the rotor alignment tool.

(5) Place a new oil seal in opening of the front oil pump housing (lip of seal facing inward). Using Tool C-3757, drive the seal into the housing until tool bottoms.

FRONT OIL PUMP AND REACTION SHAFT SUPPORT—A-727-A AND B

Disassembly

Figure 84 shows the front oil pump and reaction shaft support disassembled.

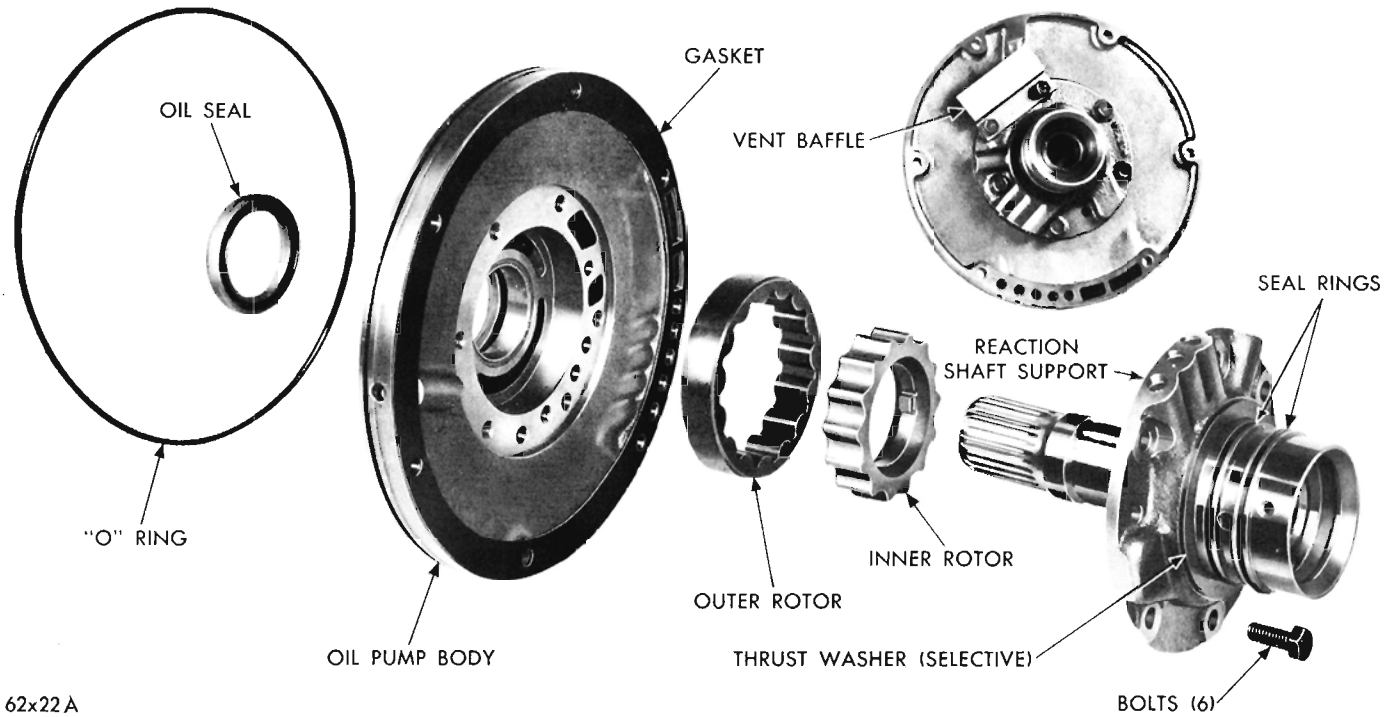

62x22A

Fig. 84—Front Pump and Reaction Shaft Support

- (1) Remove the bolts from the rear side of the reaction shaft support, and remove the vent baffle and lift the support off the oil pump.
- (2) Remove the rubber seal ring from the front pump body flange.
- (3) Drive out the oil seal with a blunt punch.

- (2) Place the removing head Tool SP-3550 in the bushing, and install the handle Tool SP-3549 in the removing head (Fig. 85).

- (3) Drive the bushing straight down and out of the

Inspection

Inspect the interlocking seal rings (Fig. 84) on the reaction shaft support for wear or broken locks, make sure they turn freely in the grooves. Do not remove the rings unless conditions warrant. Inspect the machined surfaces on the oil pump body and reaction shaft support for nicks and burrs. Inspect the pump body and reaction shaft support bushings for wear or scores. Inspect the oil pump rotors for scoring or pitting. With the rotors cleaned and installed in the pump body, place a straight edge across the face of the rotors and the pump body. Use a feeler gauge to measure the clearance between straight edge and face of the rotors. Clearance limits are from .001 to .0025 inch. Also, measure the rotor tip clearance between the inner and outer rotor teeth. Clearance limits are from .007 to .012 inch.

Front Pump Bushing Replacement

- (1) Place the front pump housing on a clean smooth surface with the rotor cavity down.

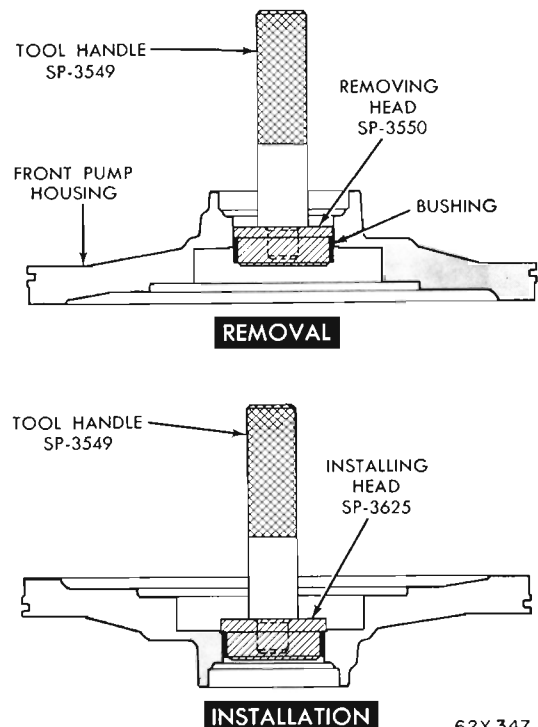

62X347

Fig. 85—Replacing Front Pump Bushing

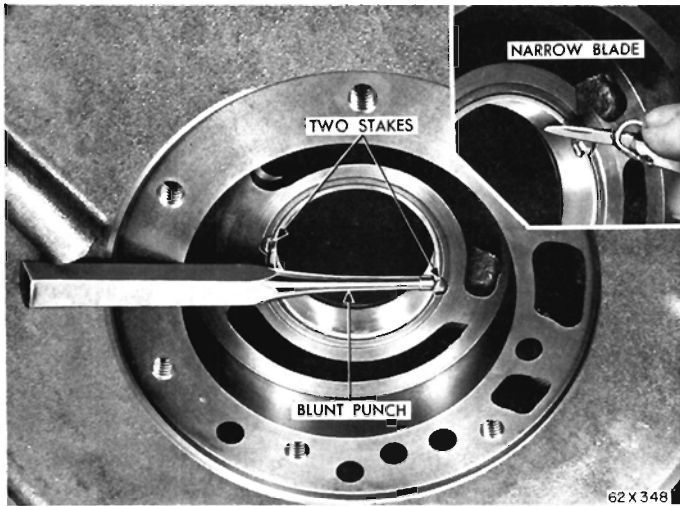

Fig. 86—Staking Front Pump Bushing

bore. Be careful not to cock the tool in the bore.

(4) Position a new bushing on the installing head Tool SP-3625.

(5) With the pump housing on a smooth clean surface (hub end down), start the bushing and installing head in the bushing bore. Install the handle Tool SP-3549 in the installing head (Fig. 85).

(6) Drive the bushing into the housing until the tool bottoms in the pump cavity. Be careful not to cock the tool during installation.

(7) Stake the bushing in place by using a blunt punch or similar tool (Fig. 86). A gentle tap at each stake slot location will suffice.

(8) Using a narrow-bladed knife or similar tool, remove the high points or burrs around the staked area (Fig. 86). Do not use a file or similar tool that will remove more metal than is necessary.

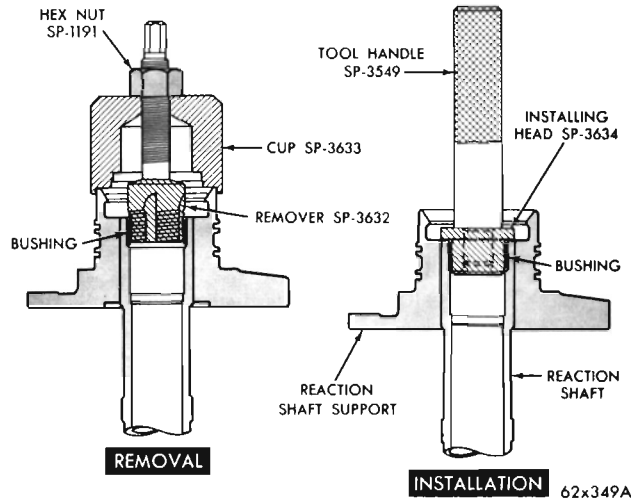

Fig. 87—Replacing Reaction Shaft Bushing

(9) Thoroughly clean the pump housing before installation.

Reaction Shaft Bushing Replacement

(1) Assemble the remover Tool SP-3632, the cup Tool SP-3633, and the hex nut Tool SP-1191 (Fig. 87).

CAUTION: Do not clamp any part of the reaction shaft or support in a vise.

(2) With the cup held firmly against the reaction shaft, thread the remover into the bushing as far as possible by hand.

(3) Use a wrench to screw the remover into the bushing 3 to 4 additional turns to firmly engage the threads in the bushings.

(4) Turn the hex nut down against the cup to pull

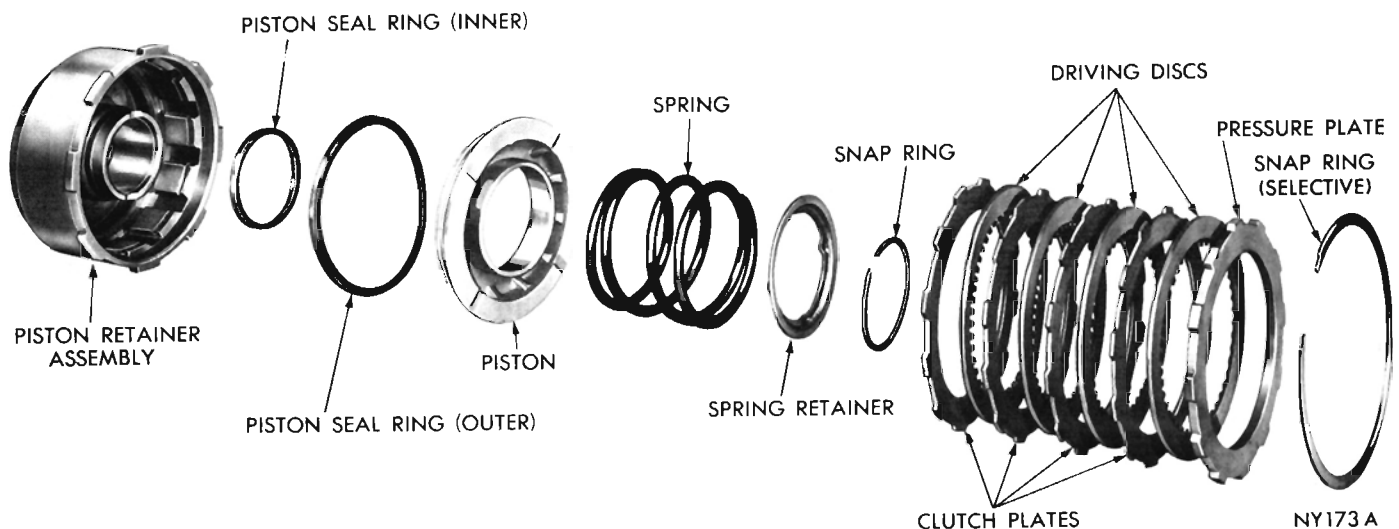

Fig. 88—Front Clutch Assembly—Disassembled

the bushing from the reaction shaft. Thoroughly clean the reaction shaft to remove the chips made by the remover threads.

(5) Lightly grip the bushing in a vise or with pliers and back the tool out of the bushing. Be careful not to damage the threads on the bushing remover.

(6) Slide a new bushing (chamfered end first) on the installing head Tool SP-3634, and start them in the bore of the reaction shaft (Fig. 87).

(7) Support the reaction shaft upright on a clean smooth surface and install handle Tool SP-3549 in the installing head. Drive the bushing into the shaft until the tool bottoms.

(8) Thoroughly clean the reaction shaft support assembly before installation.

Assembly

(1) Assemble the pump rotors in the pump housing (Fig. 84).

(2) Install the reaction shaft support and position the vent baffle over the vent opening. Install the retaining bolts and tighten to 150 inch-pounds torque.

(3) Place a new oil seal in opening of the front oil pump housing (lip of seal facing inward) using Tool C-3860 drive the seal into the housing until the tool bottoms.

FRONT CLUTCH—A-904-G AND A-904-LA

Disassembly

Figure 88 shows a disassembled view of the front clutch assembly.

(1) Use a screw driver to remove the large snap ring that secures the pressure plate in the clutch piston retainer. Lift the pressure plate and clutch plates out of the retainer.

(2) Install compressor, Tool C-3575 over the piston spring retainer, as shown in Figure 89. Compress the

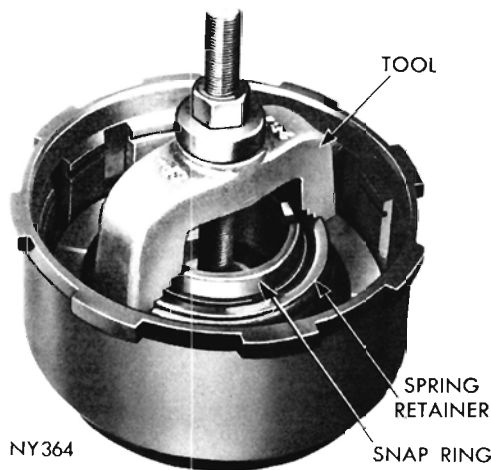

Fig. 89—Removing or Installing Front Clutch Retainer Snap Ring

spring and remove the snap ring, then slowly release the tool until the spring retainer is free of the hub. Remove the tool, retainer and spring.

(3) Invert the clutch retainer assembly and bump it on a wood block to remove the piston. Remove the seal rings from the piston and clutch retainer hub.

Inspection

Inspect the facing material on all the driving discs. Replace discs that are charred, glazed or heavily pitted. Discs should also be replaced if they show evidence of material flaking off or if the facing material can be scraped off easily. Inspect the driving disc splines for wear or other damage. Inspect the steel plate and pressure plate surfaces for burning, scoring or damaged driving lugs. Replace if necessary.

Inspect the steel plate lug grooves in the clutch retainer for smooth surfaces, plates must travel freely in grooves. Inspect the band contacting surface on the clutch retainer for scores, **the contact surface should be protected from damage during disassembly and handling.** Note the ball check in the clutch retainer, make sure the ball moves freely. Inspect the piston seal ring surfaces in the clutch retainer for nicks or deep scratches, light scratches will not interfere with the sealing of neoprene rings. Inspect the clutch retainer inner bore surface for wear from the reaction shaft support seal rings. Inspect the clutch retainer bushing for wear or scores.

Inspect the inside bore of the piston for score marks, if light, remove with crocus cloth. Inspect the seal ring grooves for nicks and burrs. Inspect the neoprene seal rings for deterioration, wear, and hardness. Inspect the piston spring, retainer and snap ring for distortion.

Front Clutch Retainer Bushing Replacement

(1) Lay the clutch retainer (open end down) on a clean smooth surface and place the removing head Tool SP-3627 in the bushing (Fig. 90). Install the handle Tool SP-3549 in the removing head.

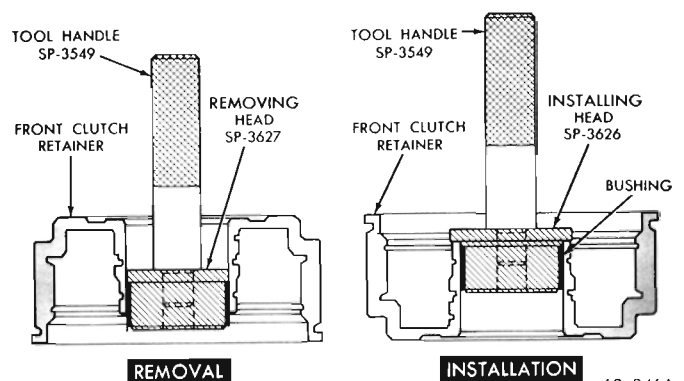

Fig. 90—Replacing Front Clutch Retainer Bushing

(2) Drive the bushing straight down and out of the clutch retainer bore. Be careful not to cock the tool in the bore.

(3) Lay the clutch retainer (open end up) on a clean smooth surface. Slide a new bushing on the installing head Tool SP-3626, and start them in the clutch retainer bore (Fig. 90).

(4) Install handle Tool SP-3549 in the installing head. Drive the bushing into the clutch retainer until the tool bottoms.

(5) Thoroughly clean the clutch retainer before assembly and installation.

Assembly

(1) Lubricate and install the inner seal ring on hub of the clutch retainer. Make sure lip of the seal faces down and is properly seated in the groove.

(2) Lubricate and install the outer seal ring on the clutch piston, with lip of the seal toward bottom of the clutch retainer. Place piston assembly in the retainer and, with a twisting motion, seat the piston in the bottom of the retainer.

(3) Place the spring on the piston hub and position the spring retainer and snap ring on the spring. Compress the spring with Tool C-3575 (Fig. 89), and seat the snap ring in the hub groove. Remove the compressor tool.

(4) Lubricate all the clutch plates, install one steel plate followed by a lined plate until all the plates are installed. Install the pressure plate and snap ring. Make sure the snap ring is properly seated.

NOTE: The A-904-G transmission uses three plates

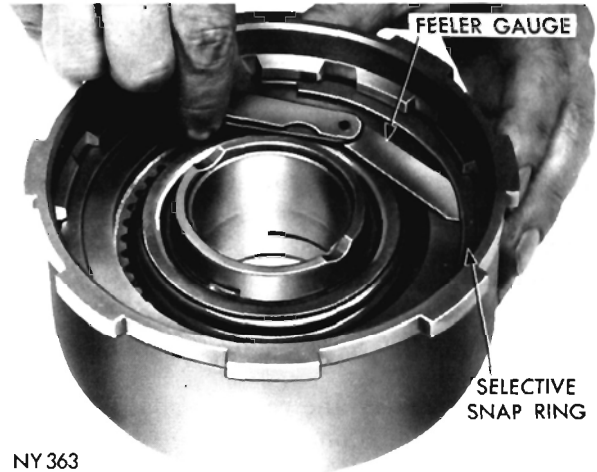

Fig. 91—Measuring Front Clutch Plate Clearance

and discs in the front clutch for both six cylinder engines. Four plates and discs are used in the A-904-LA transmission for the 273 cubic inch V-8 engine.

(5) With the front clutch completely assembled, insert a feeler gauge between the pressure plate and snap ring (Fig. 91). The clearance should be .056 to .104 inch for the four plate clutch, and .042 to .087 inch for the three plate clutch. If not, install a snap ring of proper thickness to obtain the specified clearance.

NOTE: Snap rings are the same as those used in the rear clutch and are available in .060-.062; .068-.070 and .076-.078 inch thickness.

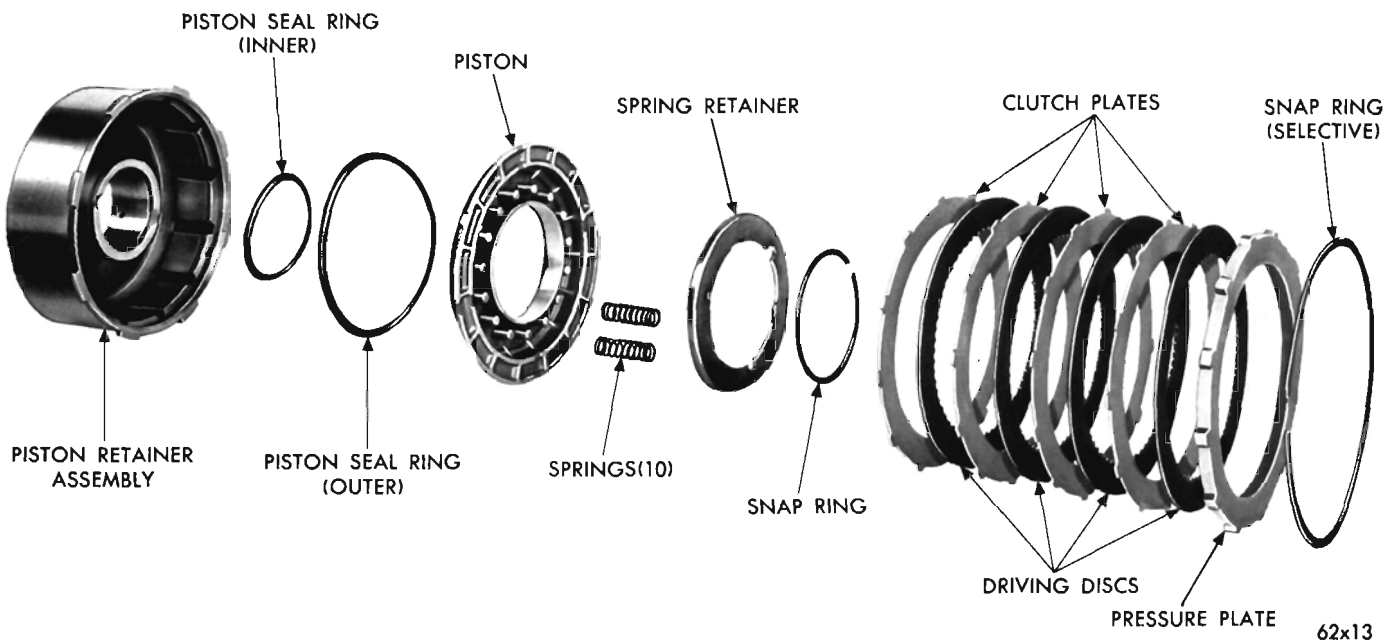

Fig. 92—Front Clutch Assembly—Disassembled

FRONT CLUTCH—A-727-A AND B

Disassembly

Figure 92 shows a disassembled view of the front clutch assembly.

(1) Using a screw driver, remove the large snap ring that secures the pressure plate in the clutch piston retainer. Lift the pressure plate and clutch plates out of the retainer.

(2) Install compressor, Tool C-3863 over the piston spring retainer, as shown in Figure 93. Compress the springs and remove the snap ring, then slowly release the tool until the spring retainer is free of the hub. Remove the tool, retainer and springs.

(3) Invert the clutch retainer assembly and bump it on a wood block to remove the piston. Remove the seals from the piston and clutch retainer hub.

Inspection

Inspect the facing material on all the driving discs. Replace discs that are charred, glazed or heavily pitted. Discs should also be replaced if they show evidence of material flaking off or if the facing material can be scraped off easily. Inspect the driving disc splines for wear or other damage. Inspect the steel plate and pressure plate surfaces for burning, scoring or damaged driving lugs. Replace if necessary.

Inspect the steel plate lug grooves in the clutch retainer for smooth surfaces, plates must travel freely in the grooves. Inspect the band contacting surface on the clutch retainer for scores. Note the ball check in the clutch retainer, make sure the ball moves free-

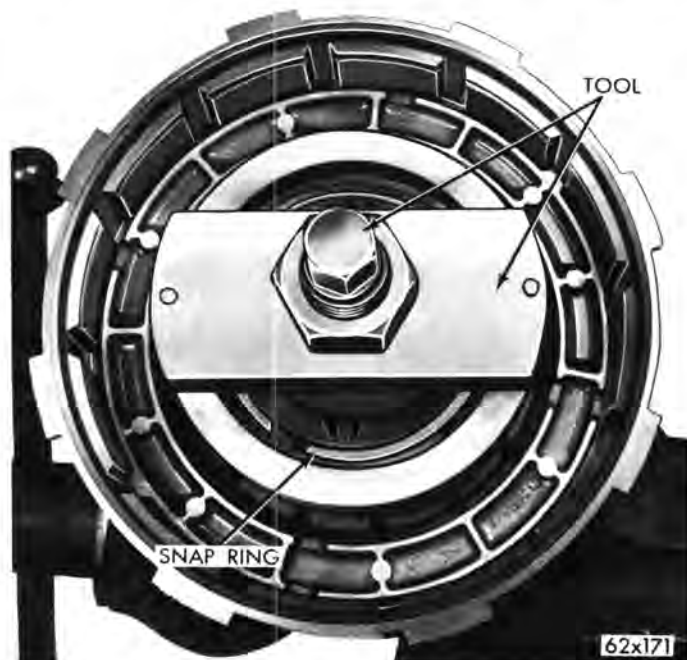

Fig. 93—Removing or Installing Front Clutch Spring Retainer Snap Ring

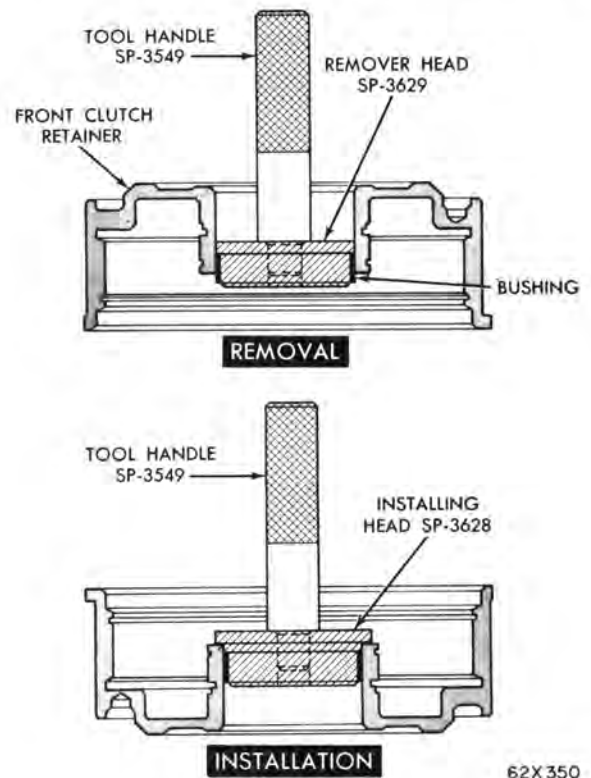

Fig. 94—Replacing Front Clutch Retainer Bushing

ly. Inspect the seal surfaces in the clutch retainer for nicks or deep scratches, light scratches will not interfere with sealing of the neoprene rings. Inspect the clutch retainer bushing for wear or scores.

Inspect the inside bore of the piston for score marks, if light, remove with crocus cloth. Inspect the seal grooves for nicks and burrs. Inspect the neoprene seals for deterioration, wear, and hardness. Inspect the piston springs, retainer and snap ring for distortion.

Front Clutch Retainer Bushing Replacement

(1) Lay the clutch retainer (open end down) on a clean smooth surface and place the removing head Tool SP-3629 in the bushing. Install the handle Tool SP-3549 in the removing head (Fig. 94).

(2) Drive the bushing straight down and out of the clutch retainer bore. Be careful not to cock the tool in the bore.

(3) Lay the clutch retainer (open end up) on a clean smooth surface. Slide a new bushing on the installing head Tool SP-3628, and start them in the clutch retainer bore.

(4) Install handle Tool SP-3549 in the installer (Fig. 94). Drive the bushing into the clutch retainer until the tool bottoms.

(5) Thoroughly clean the clutch retainer before assembly and installation.



62 X 4

**Fig. 95—Front Clutch Piston Return Springs
—Location**

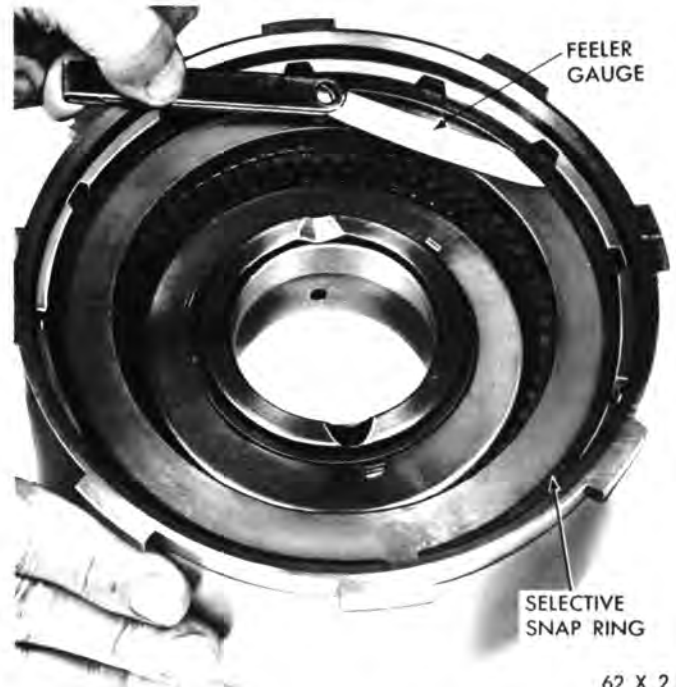

62 X 2

Fig. 96—Measuring Front Clutch Plate Clearance

Assembly

(1) Lubricate and install the inner seal on hub of the clutch retainer. Make sure the lip of the seal faces down and is properly seated in the groove.

(2) Install the outer seal on the clutch piston, with the lip of seal toward the bottom of the clutch retainer. Apply a coating of "Door Ease" to the outer edge

of the seals for easier installation of the piston assembly. Place the piston assembly in the retainer and carefully seat the piston in the bottom of the retainer.

(3) Place the 10 springs on the piston hub exactly as shown in Figure 95. Position the spring retainer and snap ring on the springs. Compress the springs with Tool C-3863 (Fig. 93), and seat the snap ring in the hub groove. Remove the compressor tool.

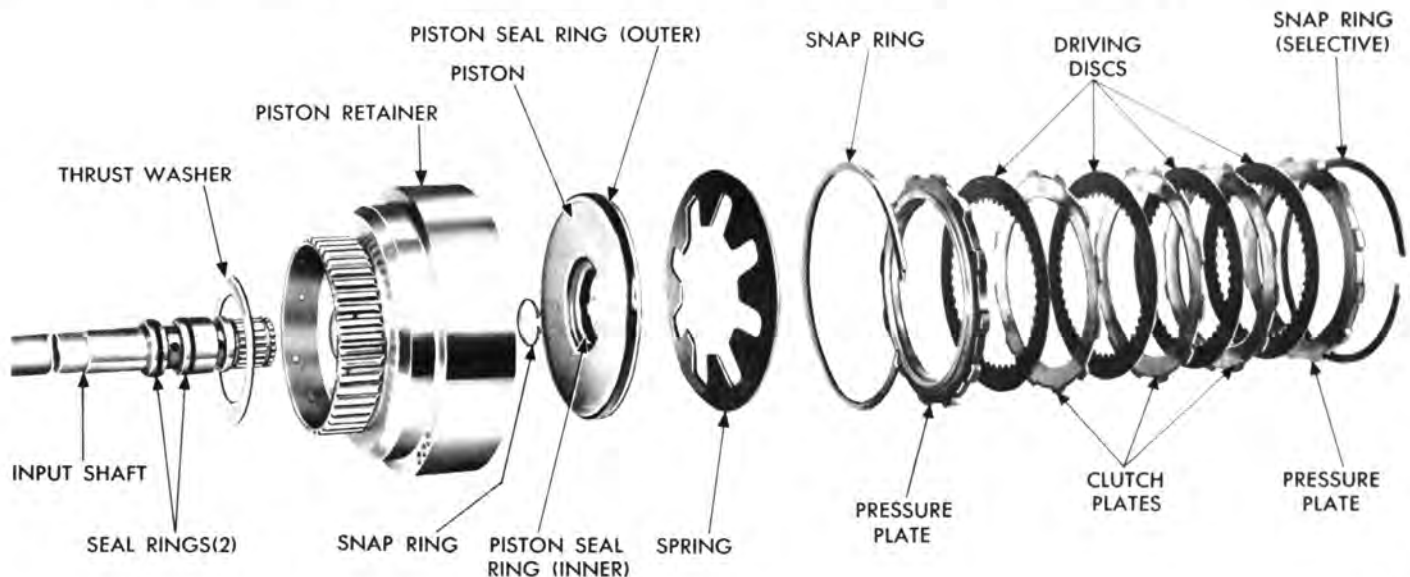

NY385B

Fig. 97—Rear Clutch Assembly—Disassembled

(4) Lubricate all the clutch plates, install one steel plate followed by a lined plate until all the plates are installed. Install the pressure plate and snap ring. Make sure the snap ring is properly seated.

(5) With the front clutch completely assembled, insert a feeler gauge between the pressure plate and snap ring (Fig. 96). The clearance should be .024 to .123 inch. If not, install a snap ring of the proper thickness to obtain the specified clearance.

NOTE: Snap rings are the same as those used in the rear clutch and are available in .060-.062, .074-.076 and .088-.090 inch thickness.

REAR CLUTCH—A-904-G AND A-904-LA

Disassembly

Figure 97 shows a disassembled view of the rear clutch assembly.

(1) Using a screw driver, remove the large snap ring that secures the pressure plate in the clutch piston retainer. Lift the pressure plate, clutch plates, and inner pressure plate out of the retainer.

(2) Remove the piston spring snap ring and remove the spring.

(3) Invert the clutch piston retainer assembly and bump it on a wood block to remove the piston. Remove the seals from the piston.

(4) If necessary, remove the snap ring and press the input shaft from the piston retainer.

Inspection

Inspect the facing material on all the driving discs. Replace discs that are charred, glazed or heavily pitted. Discs should also be replaced if they show evidence of material flaking off or if the facing material can be scraped off easily. Inspect the driving disc splines for wear or other damage. Inspect the steel plate and pressure plate surface for burning, scoring or damaged driving lugs. Replace if necessary. Inspect the plates and discs for flatness, they must not be warped or cone-shaped.

Inspect the steel plate lug grooves in the clutch retainer for smooth surfaces, plates must travel freely in the grooves. Note the ball check in the clutch retainer, make sure the ball moves freely. Inspect the seal ring surfaces in the clutch retainer for nicks or deep scratches, light scratches will not interfere with sealing of the neoprene rings. Inspect the neoprene seal rings for deterioration, wear and hardness. Inspect the piston spring and snap rings for distortion.

Inspect the interlocking seal rings (Fig. 97) on the input shaft for wear or broken locks, make sure they turn freely in the grooves. Do not remove the rings unless conditions warrant. Inspect the rear clutch to front clutch thrust washer for wear. Washer thickness should be .043 to .045 inch, replace if necessary.

Assembly

(1) If removed, press the input shaft into the piston retainer and install the snap ring.

(2) Lubricate and install the inner and outer seal rings on the clutch piston. Make sure the lip of the seals face toward head of the clutch retainer, and are properly seated in the piston grooves.

(3) Place piston assembly in the retainer and, with a twisting motion, seat the piston in the bottom of the retainer.

(4) Place the spring over the piston with outer edge of spring positioned below the snap ring groove. Start one end of the snap ring in the groove, make sure the spring is exactly centered on the piston, then progressively tap the snap ring into the groove (Fig. 98). Be sure the snap ring is fully seated in the groove.

(5) Install the inner pressure plate in the clutch retainer with raised portion of plate resting on the spring.

(6) Lubricate all clutch plates, install one lined plate followed by a steel plate until all the plates are installed. Install the outer pressure plate and snap ring.

(7) With the rear clutch completely assembled, insert a feeler gauge between the pressure plate and snap ring (Fig. 99). The clearance should be between

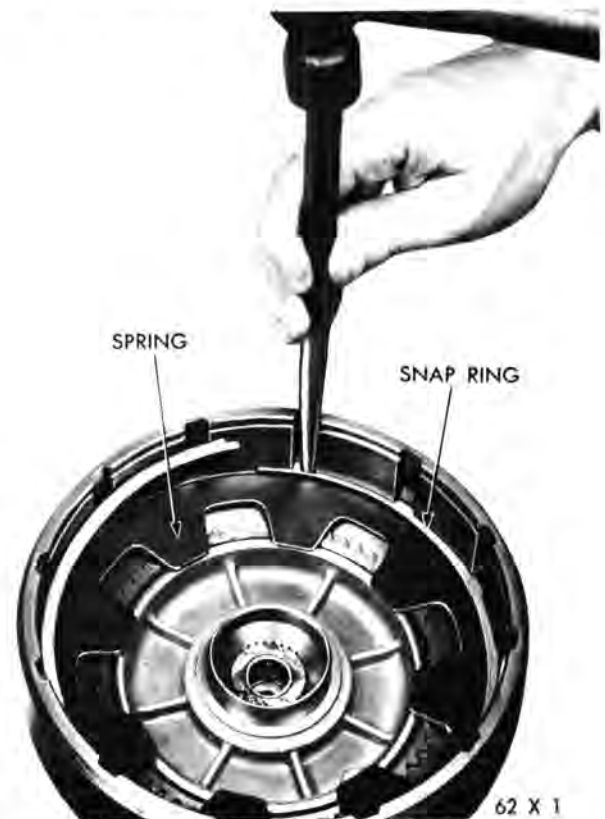

Fig. 98—Installing Rear Clutch Spring and Snap Ring

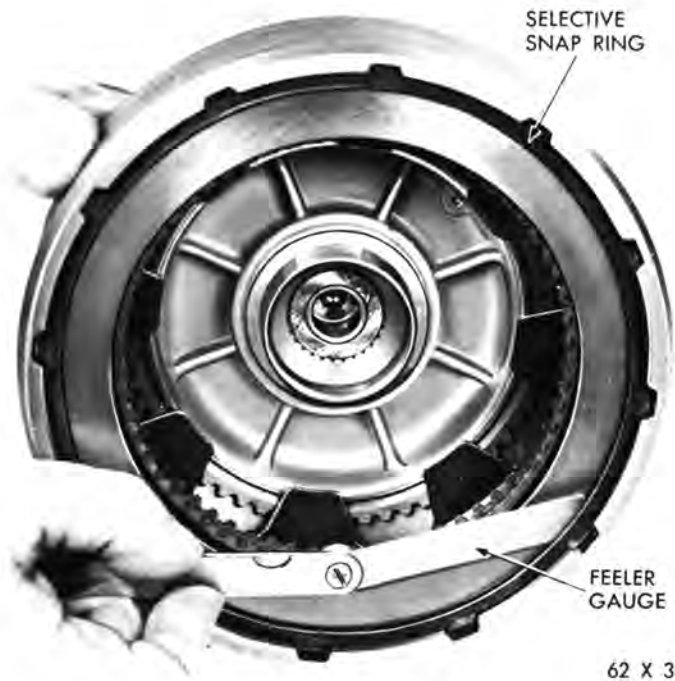

Fig. 99—Measuring Rear Clutch Plate Clearance

.018 to .036 inch. If not, install a snap ring of proper thickness to obtain the specified clearance.

NOTE: Rear clutch plate clearance is very important in obtaining the proper clutch operation. The clearance can be adjusted by the use of various thickness outer snap rings. Snap rings are available in .060-.062, .068-.070 and .076-.078 inch thickness.

REAR CLUTCH—A-727-A AND B

Disassembly

Figure 100 shows a disassembled view of the rear clutch assembly.

(1) Use a screw driver to remove the large snap ring that secures the pressure plate in the clutch retainer. Lift the pressure plate, clutch plates, and inner pressure plate out of the retainer.

(2) Remove the piston spring snap ring and remove the spring.

(3) Invert the clutch piston retainer assembly and bump it on a wood block to remove the piston. Remove the seals from the piston.

(4) If necessary, remove the snap ring and press the input shaft from the clutch piston retainer.

Inspection

Inspect the facing material on all the driving discs. Replace the discs that are charred, glazed or heavily pitted. Discs should also be replaced if they show evidence of material flaking off or if the facing material can be scraped off easily. Inspect the driving disc splines for wear or other damage. Inspect the steel plate and pressure plate surfaces for burning, scoring or damaged driving lugs. Replace if necessary.

Inspect the steel plate lug grooves in the clutch retainer for smooth surfaces, plates must travel freely in the grooves. Note the ball check in the piston, make sure the ball moves freely. Inspect the seal surfaces in the clutch retainer for nicks or deep scratches, light scratches will not interfere with sealing of the neoprene seals. Inspect the neoprene seals

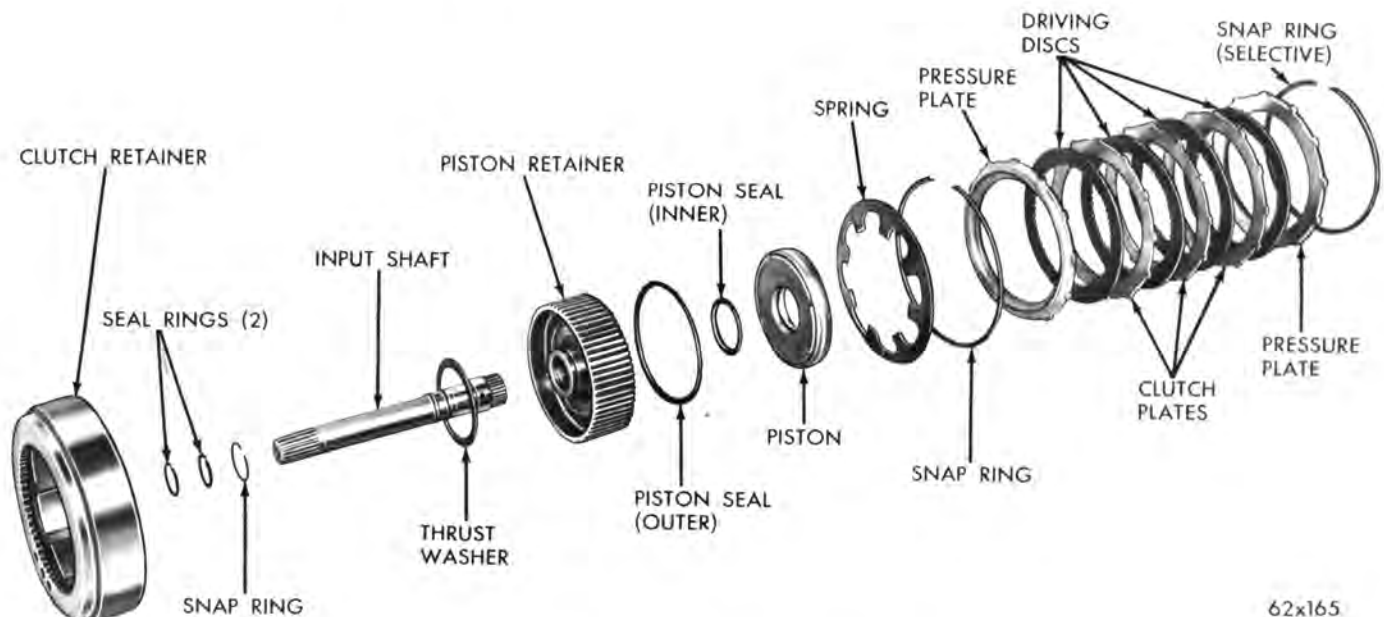

Fig. 100—Rear Clutch Assembly—Disassembled

for deterioration, wear, and hardness. Inspect the piston spring and snap rings for distortion.

Inspect the interlocking seal rings (Fig. 100) on the input shaft for wear or broken locks, make sure they turn freely in the grooves. Do not remove the rings unless conditions warrant. Inspect the bushing in the input shaft for wear or scores. Inspect the rear clutch to front clutch thrust washer for wear. Washer thickness should be .061 to .063 inch, replace if necessary.

Input Shaft Bushing Replacement

(1) Clamp the input shaft in a vise with soft jaws, being careful not to clamp on the seal ring lands or bearing journals.

(2) Assemble the remover Tool SP-3630, the cup Tool SP-3633, and the hex nut Tool SP-1191 (Fig. 101).

(3) With the cup held firmly against the clutch piston retainer, thread the remover into the bushing as far as possible by hand.

(4) Using a wrench, screw the remover into the bushing 3 to 4 additional turns to firmly engage the threads in the bushing.

(5) Turn the hex nut down against the cup to pull the bushing from the input shaft.

(6) Thoroughly clean the input shaft to remove the chips made by the remover threads. Make certain the small lubrication hole next to the ball in the end of the shaft is not plugged with chips. Be sure no chips are lodged next to the steel ball.

(7) Slide a new bushing on the installing head Tool SP-3636, and start them in the bore of the input shaft.

(8) Stand the input shaft upright on a clean smooth surface and install handle Tool SP-3549 in the installing head (Fig. 101). Drive the bushing into the shaft until the tool bottoms.

(9) Thoroughly clean the input shaft and clutch piston retainer before assembly and installation.

Assembly

(1) If removed, press the input shaft into the clutch piston retainer and install the snap ring.

(2) Lubricate and install the inner and outer seal rings on the clutch piston. Make sure the lip of the seals face toward the head of the clutch retainer, and are properly seated in the piston grooves.

(3) Place the piston assembly in the retainer and, with a twisting motion, seat the piston in bottom of the retainer.

(4) Position the clutch retainer over the piston retainer splines and support the assembly so the clutch retainer remains in place.

(5) Place the spring over the piston with outer edge of spring positioned below the snap ring groove. Start one end of the snap ring in the groove, make sure the spring is exactly centered on the piston, then progressively tap the snap ring into the groove (Fig. 98). Be sure the snap ring is fully seated in the groove.

(6) Install the inner pressure plate in the clutch retainer with raised portion of the plate resting on the spring.

(7) Lubricate all the clutch plates, install one lined plate followed by a steel plate until all the plates are installed. Install the outer pressure plate and snap ring.

NOTE: The A-727-A transmission uses three discs and two steel plates in the rear clutch for the 318 cubic inch engine. The A-727-B transmission uses four discs and three steel plates in the rear clutch with engines greater than 318 cubic inch displacement.

(8) With the rear clutch completely assembled, insert a feeler gauge between the pressure plate and snap ring (Fig. 99). The clearance should be .022-.042 inch for the three-disc clutch and .026-.054 inch for the four-disc clutch. If not, install a snap ring of proper thickness to obtain the specified clearance. Low limit clearances are desirable.

NOTE: Rear clutch plate clearance is very important in obtaining proper clutch operation. The clearance can be adjusted by the use of various thickness outer snap rings. Snap rings are available in .060-.062, .074-.076 and .088-.090 inch thickness.

PLANETARY GEAR ASSEMBLIES, SUN GEAR, DRIVING SHELL—A-904-G AND A-904-LA

Measure the end play of the planetary gear assemblies, sun gear and driving shell before removing these parts from the output shaft. With the assemblies in an upright position, push the rear annulus

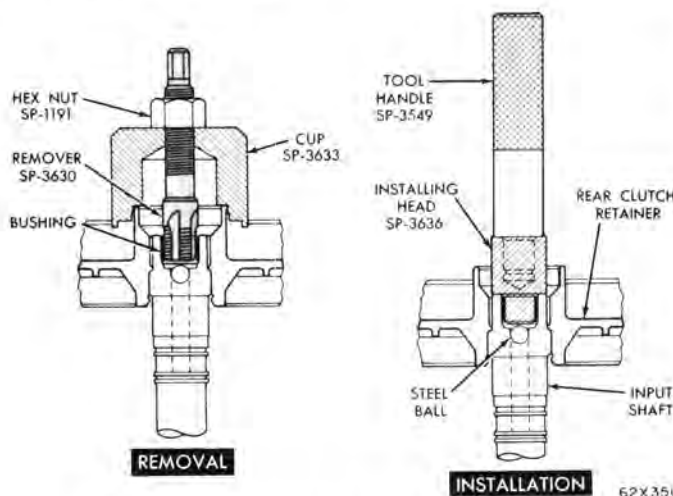

Fig. 101—Replacing Input Shaft Bushing

gear support downward on the output shaft. Insert a feeler gauge between the rear annulus gear support hub and the shoulder on the output shaft. (Fig. 102). The clearance should be .006 to .033 inch. If clearance exceeds specifications, replace thrust washers and/or necessary parts.

Disassembly

(1) Remove the selective thrust washer from the forward end of the output shaft (Fig. 103).

(2) Remove the selective snap ring from the forward end of the output shaft, then slide the front planetary assembly off the shaft.

(3) Remove the snap ring and thrust washer from forward hub of the front planetary gear assembly, slide the front annulus gear and support off the planetary gear set (Fig. 103). Remove the thrust washer from rear side of the planetary gear set. If necessary, remove the snap ring from front of the annulus gear to separate the support from the annulus gear.

(4) Slide the sun gear, driving shell and rear planetary assembly off the output shaft.

(5) Lift the sun gear and driving shell off the rear planetary assembly. Remove the snap ring and steel washer from the sun gear (rear side of driving shell). Slide the sun gear out of the driving shell, and remove the snap ring and steel washer from the opposite end of the sun gear if necessary.

(6) Remove the thrust washer from the forward

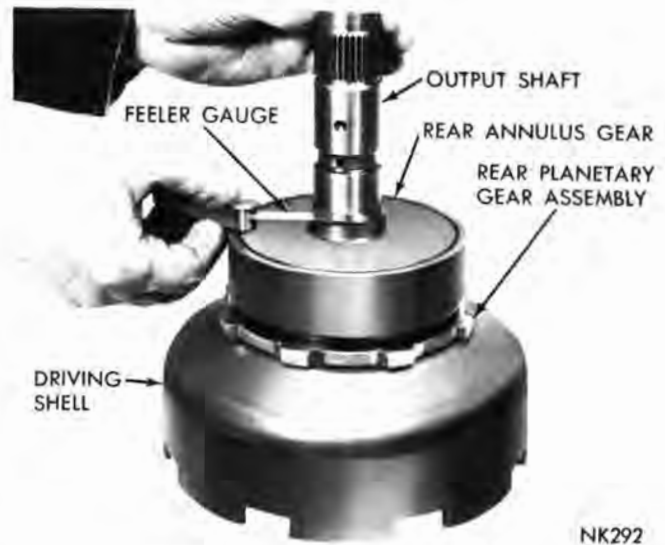

NK292

Fig. 102—Measuring End Play of Planetary Gear Assembly, Sun Gear and Driving Shell

side of the rear planetary assembly and remove the planetary gear set from the rear annulus gear. If necessary, remove the snap ring from the rear of the annulus gear to separate the support from the annulus gear.

Inspection

Inspect the bearing surfaces on the output shaft

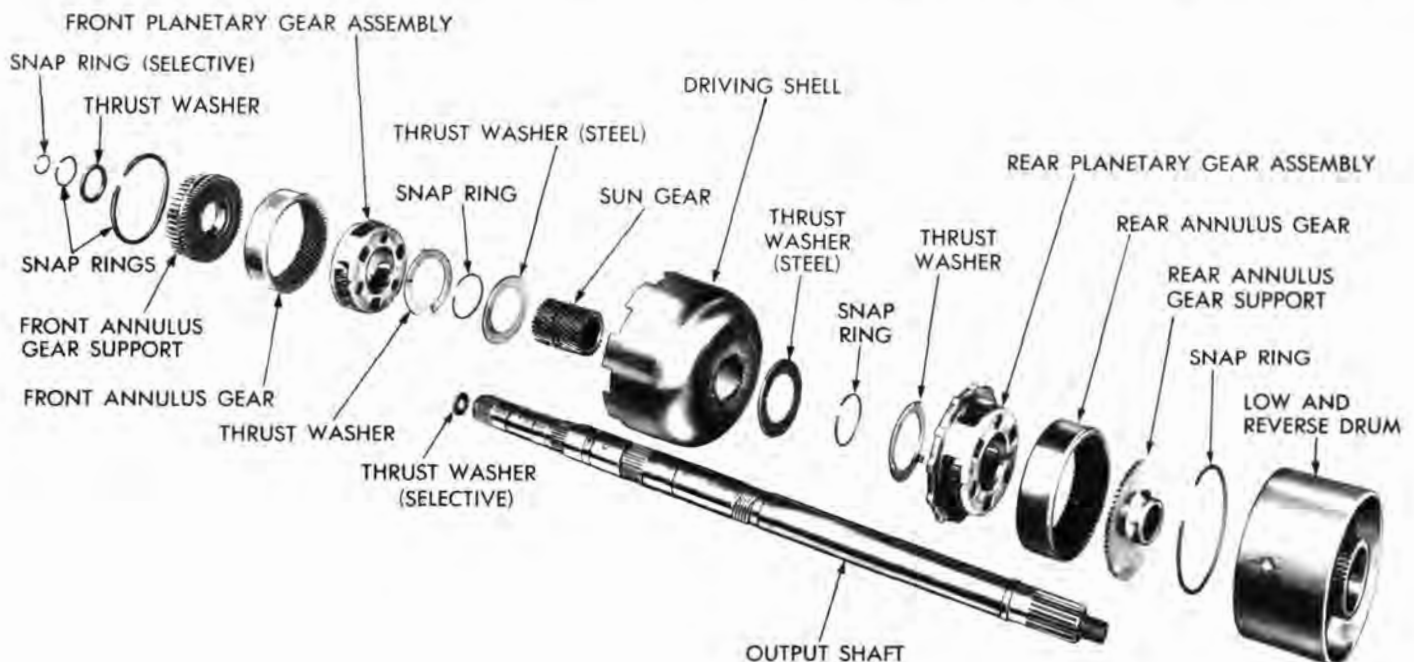

NY 176C

Fig. 103—Planetary Gear Assemblies, Sun Gear, Driving Shell, Low-Reverse Drum and Output Shaft—Disassembled

for nicks, burrs, scores or other damage. Light scratches, small nicks or burrs can be removed with crocus cloth or a fine stone. Inspect the speedometer drive gear for any nicks or burrs, and remove with a sharp edged stone. Make sure all oil passages in the shaft are open and clean.

Inspect bushings in sun gear for wear or scores, replace sun gear assembly if bushings are damaged. Inspect all thrust washers for wear and scores, replace if damaged or worn below specifications. Inspect thrust faces of planetary gear carriers for wear, scores or other damage, replace as required. Inspect planetary gear carrier for cracks and pinions for broken or worn gear teeth, and for broken pinion shaft lock pins. Inspect annulus gear and driving gear teeth for damage. Replace distorted lock rings.

Assembly

Refer to Figure 103 for parts reference.

- (1) Place the rear annulus gear support in the annulus gear and install the snap ring.
- (2) Position the rear planetary gear assembly in the rear annulus gear and place the thrust washer on the front side of the planetary gear assembly.
- (3) Insert the output shaft in the rear opening of the rear annulus gear. Carefully work the shaft through the annulus gear support and planetary gear assembly. Make sure the shaft splines are fully engaged in splines of the annulus gear support.
- (4) Install the steel washer and snap ring on one end of the sun gear. Insert the sun gear through the front side of the driving shell, install the rear steel washer and snap ring.

(5) Carefully slide the driving shell and sun gear assembly on the output shaft, engaging the sun gear teeth with the rear planetary pinion teeth.

(6) Place the front annulus gear support in the annulus gear and install the snap ring.

(7) Position the front planetary gear assembly in the front annulus gear, place thrust washer over the planetary gear assembly hub and install the snap ring. Position the thrust washer on the rear side of the planetary gear assembly.

(8) Carefully work the front planetary and annulus gear assembly on the output shaft, meshing the planetary pinions with the sun gear teeth.

(9) With all components properly positioned, install selective snap ring on front end of the output shaft. Remeasure the end play of the assembly.

NOTE: The clearance can be adjusted by the use of various thickness snap rings. Snap rings are available in .040-.044, .048-.052 and .059-.065 inch thickness.

PLANETARY GEAR ASSEMBLIES, SUN GEAR, DRIVING SHELL—A-727-A AND B

Measure the end play of the planetary gear assemblies, sun gear and driving shell before removing these parts from the output shaft. With the assembly in an upright position, push the rear annulus gear support downward on the output shaft. Insert a feeler gauge between the rear annulus gear support hub and the shoulder on the output shaft (Fig. 102). The clearance should be .010 to .039 inch. If clearance exceeds specifications, replace thrust washers and/or necessary parts.

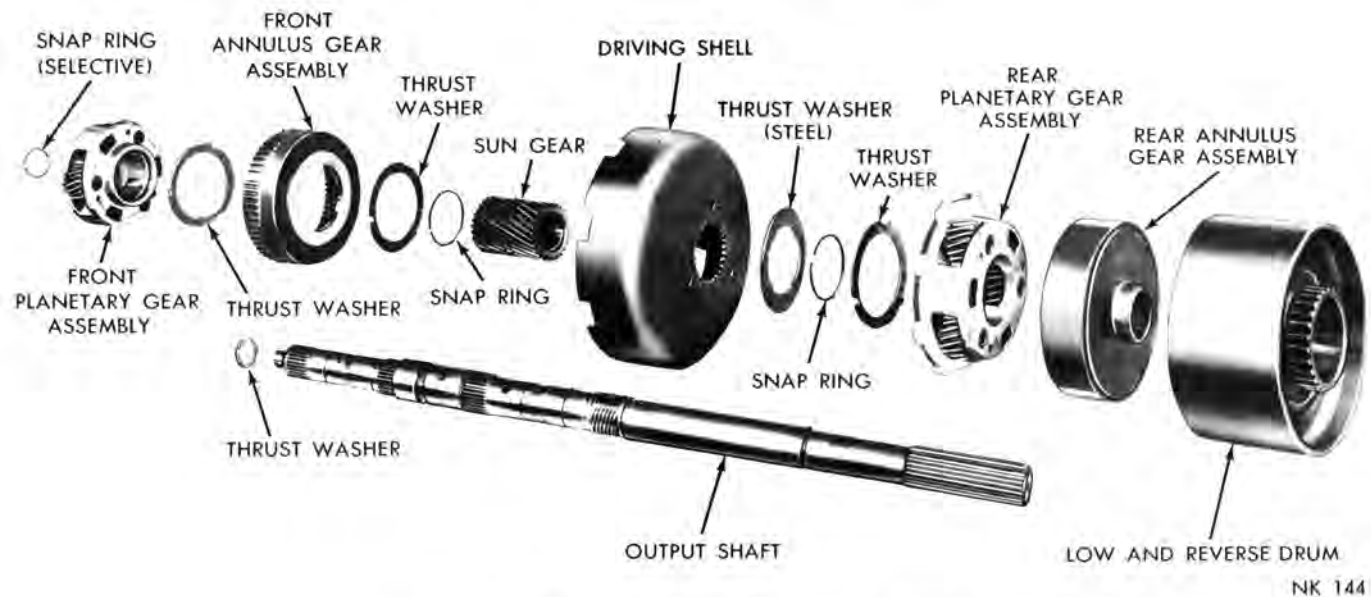

Fig. 104—Planetary Gear Assemblies, Sun Gear, Driving Shell, Low-Reverse Drum and Output Shaft—Disassembled

NK 144

Disassembly

(1) Remove the thrust washer from the forward end of the output shaft (Fig. 104).

(2) Remove the selective snap ring from the forward end of the output shaft, then slide the front planetary assembly off the shaft.

(3) Slide the front annulus gear off the planetary gear set (Fig. 104). Remove the thrust washer from the rear side of the planetary gear set.

(4) Slide the sun gear, driving shell and the rear planetary assembly off the output shaft.

(5) Lift the sun gear and driving shell off the rear planetary gear assembly. Remove the thrust washer from inside the driving shell. Remove snap ring and steel washer from the sun gear (rear side of driving shell) and slide the sun gear out of the shell. Remove the front snap ring from the sun gear if necessary. Note that the front end of the sun gear is longer than the rear.

(6) Remove the thrust washer from the forward side of the rear planetary gear assembly, remove the planetary gear set from the rear annulus gear.

Inspection

Inspect the bearing surfaces on the output shaft for nicks, burrs, scores or other damage. Light scratches, small nicks or burrs can be removed with crocus cloth or a fine stone. Inspect the speedometer drive gear for any nicks or burrs, and remove with a sharp edged stone. Make sure all oil passages in the shaft are open and clean.

Inspect bushings in the sun gear for wear or scores, replace the sun gear assembly if bushings are damaged. Inspect all the thrust washers for wear and scores, replace if damaged or worn below specifications. Inspect the thrust faces of the planetary gear carriers for wear, scores or other damage, replace as required. Inspect the planetary gear carrier for cracks and pinions for broken or worn gear teeth and for broken pinion shaft lock pins. Inspect the annulus gear and driving gear teeth for damage. Replace distorted lock rings.

Assembly

Refer to Figure 104 for parts reference.

(1) Position the rear planetary gear assembly in the rear annulus gear. Place the thrust washer on the front side of the planetary gear assembly.

(2) Insert the output shaft in the rear opening of the rear annulus gear. Carefully work the shaft through the annulus gear and planetary gear assembly. Make sure the shaft splines are fully engaged in splines of the annulus gear.

(3) Install the snap ring in the front groove of the sun gear (long end of gear). Insert the sun gear

through the front side of the driving shell, install the rear steel washer and snap ring.

(4) Carefully slide the driving shell and sun gear assembly on the output shaft, engaging the sun gear teeth with the rear planetary pinion teeth. Place the thrust washer inside the front driving shell.

(5) Place the thrust washer on the rear hub of the front planetary gear set, then slide the assembly into the front annulus gear.

(6) Carefully work the front planetary and annulus gear assembly on the output shaft, meshing the planetary pinions with the sun gear teeth.

(7) With all components properly positioned, install selective snap ring on front end of the output shaft. Re-measure the end play of the assembly.

NOTE: The clearance can be adjusted by the use of various thickness snap rings. Snap rings are available in .048-.052, .055-.059 and .062-.066 inch thickness.

OVERRUNNING CLUTCH**Inspection**

Inspect the clutch rollers for smooth round surfaces, they must be free of flat spots and chipped edges. Inspect the roller contacting surfaces in the cam and race for brinelling. Inspect the roller springs for distortion, wear or other damage.

A-727-A and B: Inspect the cam set screw for tightness. If loose, tighten and restake the case around the screw.

**Overrunning Clutch Cam Replacement—
A-904-G and A-904-LA**

If the overrunning clutch cam or spring retainer are found damaged, they can be replaced with a service replacement cam, spring retainer, and retaining bolts (Fig. 105). The service parts are retained in the

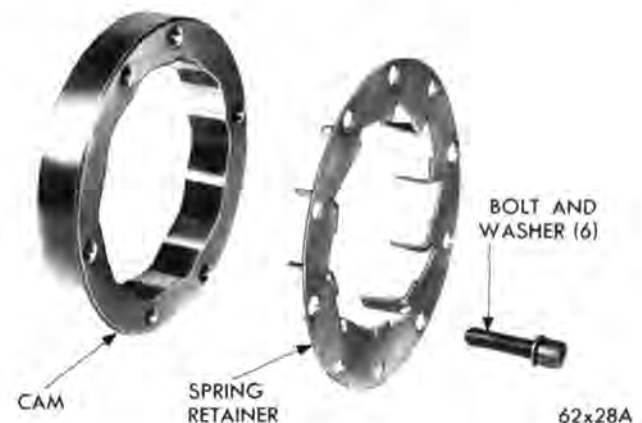

Fig. 105—Overrunning Clutch Service Replacement Cam

case with bolts instead of rivets. To install, proceed as follows:

(1) Drive the rear oil pump body rearward out of the case with a wood block and hammer.

(2) Center punch the rivets **exactly** in the center of each rivet head (Fig. 106).

(3) Drill through each rivet head with a $\frac{3}{8}$ inch drill. **Be very careful not to drill into the transmission case.** Chip off the rivet heads with a small chisel, then drive the rivets and cam from the case with a blunt punch of proper size.

(4) Carefully enlarge the rivet holes in the case with a $\frac{17}{64}$ inch drill. Remove all chips and foreign matter from the case, make sure the cam area is free of chips and burrs.

(5) To install, position the cam and roller spring retainer in the case. Align the cam bolt holes with the holes in the case, then thread all five retaining bolt and washer assemblies into the cam a few turns. The Belleville washers must be installed so its inner diameter is coned toward the bolt head (Fig. 107).

(6) Tap the cam firmly into the case if necessary. Draw the retaining bolts down evenly, then tighten to 100 inch-pounds torque.

(7) To install the rear oil pump body, refer to Page 86.

Overrunning Clutch Cam Replacement— A-727-A and B

If the overrunning clutch cam and/or the roller spring retainer are found damaged, replace the cam and spring retainer in the following manner:

(1) Remove the set screw from the case below the clutch cam.

(2) Insert a punch through the pump body bolt holes and drive the cam from the case (Fig. 108).



Fig. 106—Center Punch Rivet Heads



Fig. 107—Cam Retaining Bolts Installed

Alternate the punch from one bolt hole to another so the cam will be driven evenly from the case.

(3) Clean all burrs and chips from the cam area in the case.

(4) Place the spring retainer on the cam, making sure the retainer lugs snap firmly into the notches on the cam.

(5) Position the cam in the case with cam serrations aligned with those in the case. Tap the cam **evenly** into the case as far as possible with a soft mallet.

(6) Install Tool C-3863, as shown in Figure 109, tighten nut on the tool to seat the cam into the case. Make sure the cam is firmly bottomed, then install the cam retaining set screw. Stake the case around the set screw to prevent it from coming loose.



Fig. 108—Removing Overrunning Clutch Cam

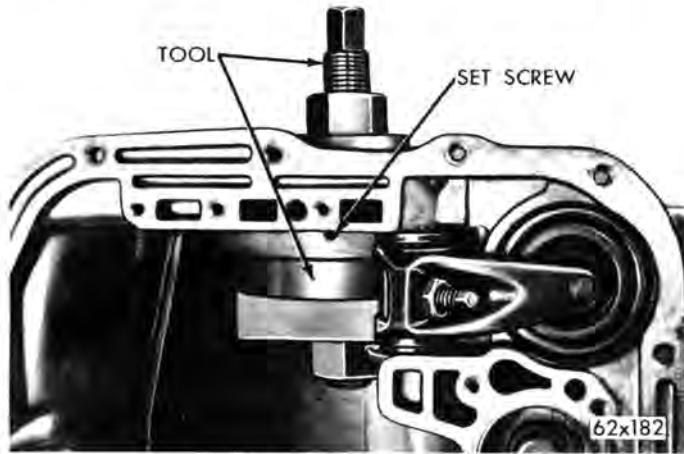

Fig. 109—Installing Overrunning Clutch Cam

KICKDOWN SERVO AND BAND

Inspection

Figure 110 shows a disassembled view of the kickdown servo assembly.

NOTE: The large outer spring shown in Figure 110 is not used in the A-904-G and A-904-LA transmissions. Also, it is not used in maximum performance vehicles with the A-727-A and B transmissions.

Inspect the piston and guide seal rings for wear, and make sure they turn freely in the grooves. It is not necessary to remove the seal rings unless conditions warrant. Inspect the piston for nicks, burrs, scores and wear. Inspect the piston bore in the case for scores or other damage. Inspect the fit of the guide on the piston rod. Inspect the piston spring for distortion.

Inspect the band lining for wear and bond of lining to the band. Inspect the lining for black burn marks, glazing, non-uniform wear pattern and flaking. If the lining is worn so the grooves are not visible at the ends or any portion of the bands, replace the band. Inspect the band for distortion or cracked ends.

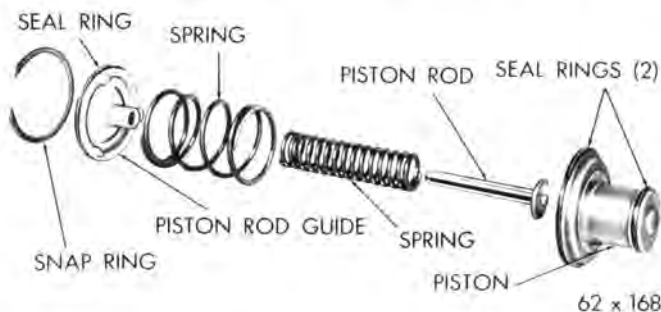

Fig. 110—Kickdown Servo-Disassembled

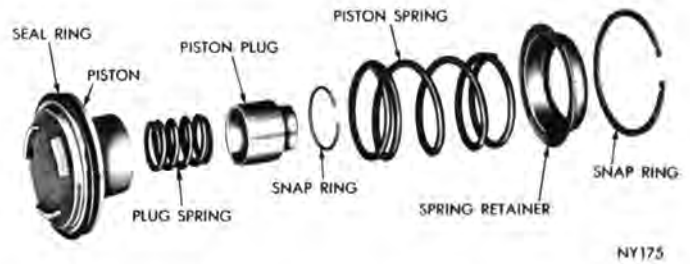

Fig. 111—Low and Reverse Servo—Disassembled

LOW—REVERSE SERVO AND BAND

Disassembly

(1) Remove the snap ring from the piston and remove the piston plug and spring (Fig. 111).

Inspection

Inspect the seal for deterioration, wear and hardness. Inspect the piston and piston plug for nicks, burrs, scores and wear; piston plug must operate freely in the piston. Inspect the piston bore in the case for scores or other damage. Inspect the springs for distortion.

Inspect the band lining for wear and bond of lining to the band. If the lining is worn so the grooves are not visible at the ends or any portion of the band, replace the band. Inspect the band for distortion or cracked ends.

Assembly

(1) Lubricate and insert the piston plug and spring in the piston, and secure with the snap ring.

ASSEMBLY—SUB-ASSEMBLY INSTALLATION

The assembly procedures given here include the installation of the sub-assemblies in the transmission case and adjusting the drive train end play. Do not use force to assemble mating parts. If the parts do not assemble freely, investigate the cause, and correct the trouble before proceeding with the assembly procedures. Always use new gaskets during the assembly operations.

IMPORTANT: Use only Automatic Transmission Fluid Type "A" Suffix "A" to lubricate the transmission parts during assembly.

Overrunning Clutch

(1) Insert the clutch hub (race) inside the overrunning clutch cam, then install the springs and rollers exactly as shown in Figure 112.

Low—Reverse Servo and Band

(1) Carefully work the servo piston assembly into

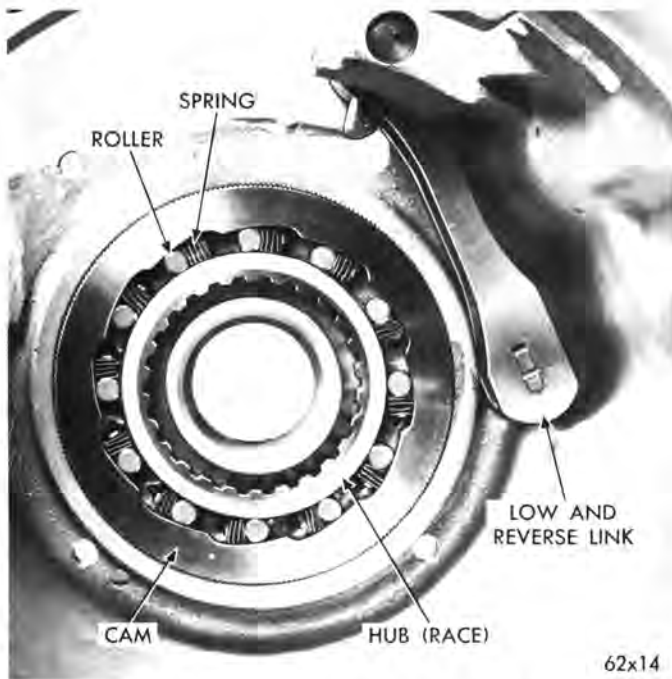

Fig. 112—Overrunning Clutch, Low and Reverse Band Link

the case with a twisting motion. Place the spring, retainer and snap ring over the piston (Fig. 111).

(2) Compress the low and reverse servo piston spring by using engine valve spring compressor Tool C-3422, then install the snap ring.

(3) Position the rear band in the case, install the short strut, then connect the long link and anchor to the band (Fig. 113). Screw in the band adjuster just enough to hold the strut in place. Install the low-reverse drum.

A-727-A and B: Be sure the long link and anchor assembly is installed, as shown in Figure 112 to provide the running clearance for the low and reverse drum.

Kickdown Servo

(1) Carefully push the servo piston into the case bore. Install the piston rod, the two springs and the guide (Fig. 110). **The A-904-G and A-904-LA transmissions use one small spring only. Also, one small spring only is used in the maximum performance vehicles with A-727-A and B transmissions.**

(2) Compress the kickdown servo springs by using engine valve spring compressor Tool C-3422, then install the snap ring.

Planetary Gear Assemblies, Sun Gear, Driving Shell

(1) While supporting the assembly in the case, insert the output shaft through the rear pump housing. Carefully work the assembly rearward engaging the

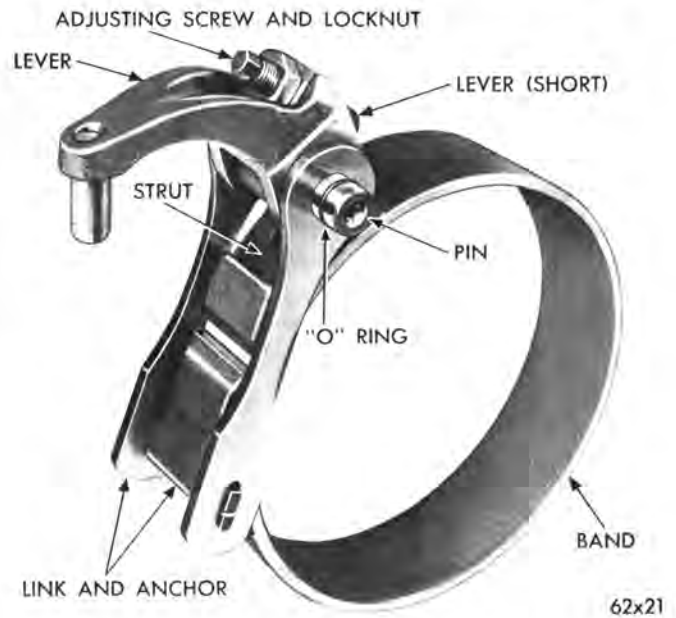

Fig. 113—Low-Reverse Band and Linkage

rear planetary carrier lugs into the low-reverse drum slots.

CAUTION: Be very careful not to damage the ground surfaces on the output shaft during installation.

Rear Oil Pump

(1) Place the outer rotor in the pump body.

(2) Turn the output shaft so the inner rotor driving ball pocket is up. Install the ball and slide the inner rotor on the output shaft in alignment with the ball (Fig. 56).

(3) Install the oil pump cover with the retaining bolts threaded in a few turns. Slide aligning sleeve, Tool C-3762 (A-904-G and A-904-LA) or Tool C-3864 (A-727-A and B) all the way in until it bottoms against the rotors (Fig. 57), then tighten the cover bolts evenly to 140 inch-pounds torque.

Front and Rear Clutch Assemblies

The front and rear clutches, front band, front oil pump and reaction shaft support are more easily installed with the transmission in an upright position.

If transmission repair stand DD-1014 was not available to support the transmission, an alternate method is outlined in Steps 1 and 2.

(1) Cut a 3½ inch diameter hole in a bench, in the end of a small oil drum or a large wooden box strong enough to support the transmission. Using the rear oil pump cover as a template, cut or file notches at the edge of the 3½ inch hole so the cover will fit and lay flat in the hole. (Reinstall the pump cover on the transmission).

(2) Carefully insert the output shaft into the hole to support the transmission upright, with its weight resting on the rear oil pump cover.

CAUTION: Be very careful not to push the output shaft inward as the inner rotor drive ball might nick the rear oil pump body.

(3) **A-904-G and A-904-LA:** Apply a coat of grease to the selective thrust washer (Fig. 103) and install the washer on the front end of the output shaft.

NOTE: If the drive train end play was not within specifications (.023 to .089 inch), when tested on Page 79, replace the thrust washer with one of proper thickness.

The following selective washers are available for A-904-G and A-904-LA transmissions:

Thickness	Color
.052-.054 inch	Natural
.068-.070 inch	Red
.083-.085 inch	Black

A-727-A and B: Apply a coat of grease on the input to output shaft thrust washer (Fig. 104), and install the washer on the front end of the output shaft.

(4) Align the front clutch plate inner splines, and place the assembly in position on the rear clutch. Make sure the front clutch plate splines are fully engaged on the rear clutch splines.

(5) Align the rear clutch plate inner splines, grasp the input shaft and lower the two clutch assemblies into the transmission case.

(6) Carefully work the clutch assemblies in a circular motion to engage the rear clutch splines over the splines of the front annulus gear. Make sure the front clutch drive lugs are fully engaged in the slots in the driving shell.

Front Band

Figure 114 shows a disassembled view of the kick-down band assembly.

- (1) Slide the band over the front clutch assembly.
- (2) Install the band strut, screw in the adjuster just

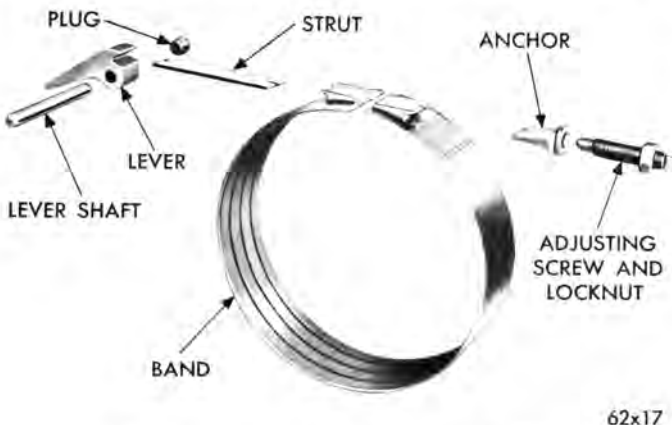

Fig. 114—Kickdown Band and Linkage—Disassembled

enough to hold the strut and anchor in place.

Front Oil Pump and Reaction Shaft Support

If difficulty was encountered in removing the front oil pump assembly due to an exceptionally tight fit in the case, it may be necessary to expand the case with heat during pump installation. Using a suitable heat lamp, heat the case in the area of the front pump for a few minutes prior to installing the front pump and reaction shaft support assembly.

A-904-G and A-904-LA: Install the thrust washer on the reaction shaft support hub (Fig. 79).

A-727-A and B: If the drive train end play was not within specifications (.036-.084 inch) when measured on Page 79, replace the thrust washer on the reaction shaft support hub with one of the proper thickness (Fig. 84).

The following selective thrust washers are available for the A-727-A and B transmissions.

Thickness	Color
.061-.063 inch	Green
.084-.086 inch	Red
.102-.104 inch	Yellow

(1) Screw to pilot studs, Tool C-3288 in the front oil pump opening in the case (Fig. 115). Install a new gasket over the pilot studs.

(2) Place a new rubber seal ring in the groove on the outer flange of the oil pump housing. Make sure the seal ring is not twisted. Coat the seal ring with grease for easy installation.

(3) Insert aligning Tool C-3756 (A-904-G and A-904-LA) or C-3881 (A-727-A and B) through the pump body and engage the inner rotor.

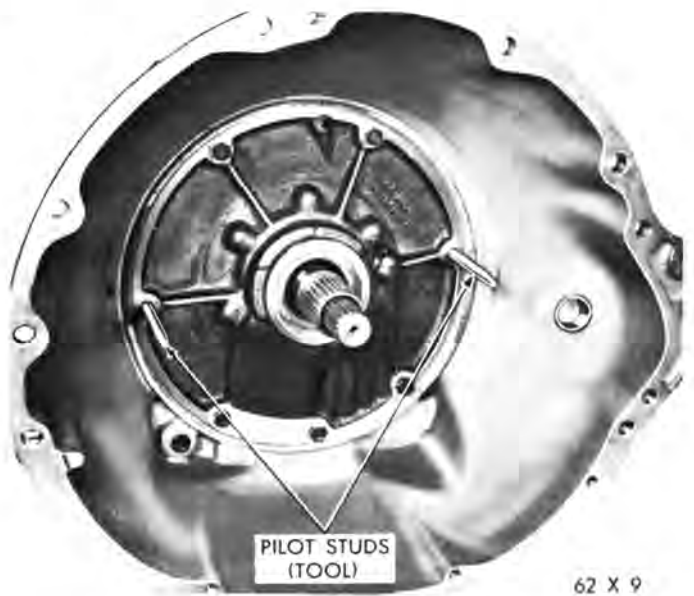

Fig. 115—Installing Front Pump and Reaction Shaft Support Assembly

(4) Install the assembly in the case, tap lightly with a soft mallet if necessary. Place the deflector over vent opening and install four pump body bolts, remove pilot studs and install the remaining bolts. Snug the bolts down evenly, then tighten to 150 inch-pounds torque. (The A-904-G and A-904-LA do not use a deflector over the vent opening.)

Governor and Support

(1) Position the support and governor body assembly on the output shaft. Align the assembly so the governor valve shaft hole in the governor body aligns with the hole in the output shaft, then slide the assembly into place. Install the snap ring behind the governor body (Fig. 54). Tighten the body to support bolts to 100 inch-pounds torque. Bend the ends of the lock straps against the bolt heads.

(2) Place the governor valve on the valve shaft, insert the assembly into the body and through the governor weights. Install the valve shaft retaining snap ring.

Extension Housing—A-904-G and A-904-LA

(1) Using a new gasket, carefully slide the extension housing into place. Install the retaining bolts and washers, tighten bolts to 25 foot-pounds torque.

(2) Install the transmission output shaft flange. Install washer with its three projections toward the flange and the nut with its convoluted surface contacting the washer. Hold the flange with Tool C-3281, and tighten nut to 175 foot-pounds torque. Torque reading must be taken as the nut passes over the hump.

IMPORTANT: Inspect the drive train end play as described on Page 79. Correct if necessary.

Output Shaft Bearing and Extension Housing—A-727-A and B

(1) Install a snap ring in the innermost groove on the output shaft. Install the bearing on the shaft with its outer race ring groove toward the front (Fig. 53). Press or tap the bearing tight against the front snap ring, then install the rear snap ring.

(2) Unwind and slide the yoke seal stop ring into place on the shaft. Install the seal with lips of seal toward the rear.

(3) Place a new extension housing gasket on the transmission case. Position the output shaft bearing retaining snap ring in the extension housing. Spread the snap ring as far as possible (Fig. 52), then carefully tap the extension housing into place. **Make sure the snap ring is fully seated in the bearing groove.**

(4) Install the gasket, plate and two screws on the bottom of the extension housing mounting pad.

(5) Install and tighten extension housing bolts to 24 foot-pounds torque.

IMPORTANT: Measure the drive train end play as described on Page 79. Correct if necessary.

Valve Body Assembly and Accumulator Piston

(1) Clean mating surfaces and inspect for burrs on both the transmission case and the valve body steel plate.

(2) Install the accumulator piston in the transmission case and place the piston spring on the accumulator piston.

(3) Carefully position the valve body assembly in the transmission case, install the retaining bolts and tighten finger tight. With the neutral starting switch installed, place the manual valve in the neutral position. Shift the valve body if necessary to center the neutral finger over the neutral switch plunger. Snug the bolts down evenly, then tighten to 100 inch-pounds torque.

(4) Connect the control cable adapter to the manual lever and install the retaining E-clip.

(5) Install the seal, flat washer and throttle lever on the throttle shaft. Tighten the clamp bolt.

(6) Adjust the kickdown, and low-reverse bands, as described on Page 59.

(7) Install the oil pan, using a new gasket. Tighten the pan bolts to 150 inch-pounds torque.

TRANSMISSION AND CONVERTER

Installation

The transmission and converter must be installed as an assembly; otherwise, the converter drive plate, front pump bushing, and oil seal will be damaged.

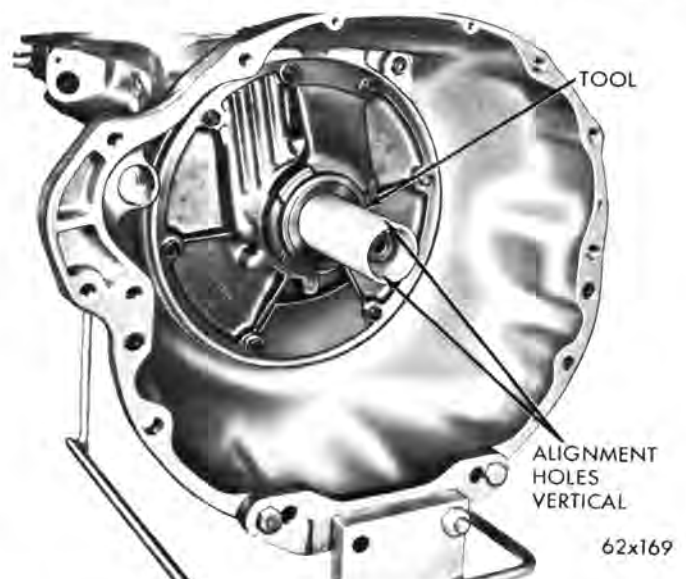
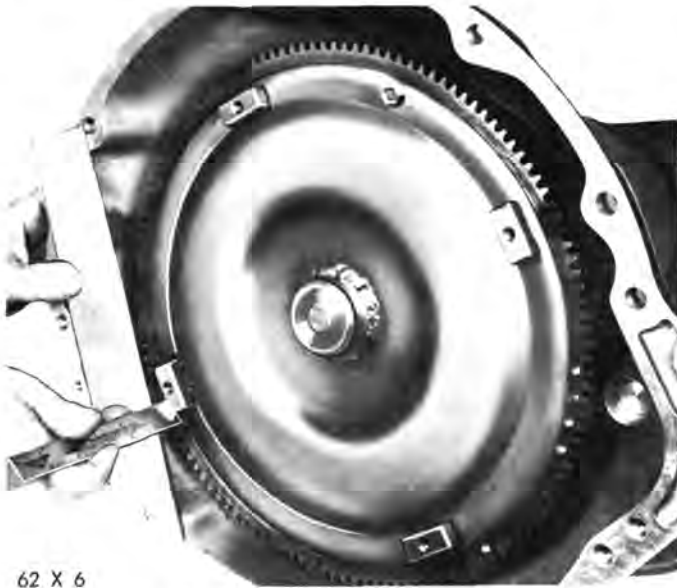

Fig. 116—Aligning Front Pump Rotors



62 X 6

Fig. 117—Measuring Converter for Full Engagement in Transmission

The drive plate will not support a load; therefore, none of the weight of the transmission should be allowed to rest on the plate during installation.

(1) Rotate the front pump rotors with Tool C-3756 (A-904-G and A-904-LA) or Tool C-3881 (A-727-A and B) until the two small holes in the handle are vertical (Fig. 116).

(2) Carefully slide the converter assembly over the input shaft and reaction shaft. Make sure the converter impeller shaft slots are also vertical and fully engage the front pump inner rotor lugs.

Test for full engagement by placing a straight edge on the face of the case (Fig. 117). The surface of the converter front cover lug should be at least $\frac{1}{2}$ inch to the rear of the straight edge when the converter is pushed all the way into the transmission.

(3) Attach a small "C" clamp to the edge of the bell housing to hold the converter in place during the transmission installation.

(4) Inspect the converter drive plate for distortion or cracks and replace if necessary.

(5) Coat the converter hub hole in the crankshaft with wheel bearing grease. Place the transmission and converter assembly on a service jack and position the assembly under the vehicle for installation. Raise or tilt as necessary until the transmission is aligned with the engine.

(6) Rotate the converter so the mark on the converter (made during removal) will align with the mark on the drive plate. The offset holes in the plate are located next to the $\frac{1}{8}$ inch hole in the inner circle of the plate. A stamped V mark identifies the offset hole in the converter front cover (Fig. 118). Carefully work the transmission assembly forward over the engine

block dowels with the converter hub entering the crankshaft opening.

(7) After the transmission is in position, install the bell housing bolts and tighten 25 to 30 foot-pounds torque.

(8) Install and tighten the two lower drive plate to converter bolts to 270 inch-pounds torque.

(9) Install the starting motor and connect the battery ground cable.

(10) Rotate the engine with the remote control switch and install the other two drive plate to converter bolts. Tighten the bolts to 270 inch-pounds torque.

(11) Install the crossmember, insulator and spring assembly. Tighten the crossmember attaching bolts to 75 foot-pounds torque. Lower the transmission so the extension housing rests on, and is aligned with the insulator. Install the insulator to extension housing bolts and tighten to 35 foot-pounds torque.

(12) Insert a screw driver through the parking lock cover plug opening and position it behind the cable adapter stop washer (Fig. 28). Hold the adapter outward while pushing the cable in as far as possible, making sure the lock-spring engages the cable. Gently pull outward on the cable housing to its limit of travel, release, then tighten the clamp bolt to 10 inch-pounds torque. Remove the screw driver and reinstall the plug in the cover.

(13) **A-904-G and A-904-LA:** Connect the propeller shaft to the front universal joint.

A-727-A and B: Clean and relubricate the front



62 X 10

Fig. 118—Converter and Drive Plate Markings

universal joint sliding yoke splines as outlined in Group "O."

Carefully guide the sliding yoke into the extension housing and on the output shaft splines. Then connect the propeller shaft to the rear axle pinion shaft yoke.

On the 121½ inch wheelbase Plymouth Station Wagon; refer to Group 2 and reinstall the torsion bar rear anchor crossmember and rubber isolators as outlined in "Torsion Bar Rubber Isolator."

(14) Install the speedometer drive pinion and sleeve.

(15) Connect the oil cooler lines to the transmission and install the oil filler tube.

(16) Connect the throttle rod to the transmission throttle lever.

Place the selector lever in the PARK position. Insert the control cable in the transmission case, push

inward on the cable making sure the lock spring engages the cable. Install the control cable adjusting wheel lock screw.

(17) Connect the wire to the neutral starting switch.

(18) Install the cover plate in front of the converter assembly.

(19) Install the transmission case to cylinder block brace.

NOTE: The converter cover plate must be between the case and the brace. The oil line bracket is attached in front of the brace. Tighten the bolts holding the brace to the case before attaching brace to the cylinder block.

(20) Refill the transmission with Automatic Transmission Fluid Type "A" Suffix "A." Refer to Page 49 for complete transmission filling instructions.

NOTE: To completely adjust the throttle linkage, gearshift control cable, and neutral starting switch, refer to Page 57, 58 and 59.

TorqueFlite Specifications

TORQUEFLITE	A-904-G & A-904-LA	A-727-A & B
TYPE	Automatic Three Speed with Torque Converter	
TORQUE CONVERTER DIAMETER	10¾ inches	11¼ inches
TORQUEFLITE—(Continued)		
OIL CAPACITY—TRANSMISSION AND TORQUE CONVERTER	A-904-G & A-904-LA	A-727-A & B
	17 pints	19½ pints
	Automatic Transmission Fluid Type AQ-ATF, Suffix "A"	
COOLING METHOD	Water-Heat Exchanger	
LUBRICATION	Pump (Rotor Type)	
CLUTCHES		
Number of Front Clutch Plates	3(170-225 Cu. In. Eng.) 4(273 Cu. In. Eng.)	4 —
Number of Front Clutch Discs	3(170-225 Cu. In. Eng.) 4(273 Cu. In. Eng.)	4 —
Number of Rear Clutch Plates	2(170-225 Cu. In. Eng.) 3(273 Cu. In. Eng.) —	2(6 Cyl. Police Cars & Taxi Cabs) 2(318 Cu. In. Eng.) 3(361-383-426 Cu. In. Eng.)
Number of Rear Clutch Discs	3(170-225 Cu. In. Eng.) 4(273 Cu. In. Eng.)	3(6 Cyl. Police Cars & Taxi Cabs) 3(318 Cu. In. Eng.) 4(361-383-426 Cu. In. Eng.)
GEAR RATIOS		
1—Low		2.45 to 1
2—Second		1.45 to 1
D—Drive		1 to 1
R—Reverse		2.20 to 1
N—Neutral		—
FRONT-REAR PUMPS		
Type		Gear (Rotary)
End Clearance		Front—.001 to .0025 inch Rear—.0015 to .003 inch
DRIVE TRAIN END PLAY023 to .089 inch	.036 to .084 inch
CLUTCH PLATE CLEARANCE		
Front Clutch042 to .087 inch (3 Disc Clutch) .056 to .104 inch (4 Disc Clutch)	.024 to .123 inch —
Rear Clutch018 to .036 inch (3 Disc Clutch) .024 to .049 inch (4 Disc Clutch)	.022 to .042 inch (3 Disc Clutch) .026 to .054 inch (4 Disc Clutch)
SNAP RINGS		
Front and Rear Clutches		
Rear Snap Ring (Selective)060 to .062 inch .068 to .070 inch .076 to .078 inch	.060 to .062 inch .074 to .076 inch .088 to .090 inch
Output Shaft (Forward End)040 to .044 inch .048 to .052 inch .059 to .065 inch	.048 to .052 inch .055 to .059 inch .062 to .066 inch
Output Shaft Bearing061 to .063 inch	—
Front and Rear Snap Ring	—	.092 to .094 inch

TRANSMISSION—(Continued)

TORQUEFLITE—(Continued)

THRUST WASHERS

Output Shaft to Input Shaft (Selective)052 to .054 inch (Natural)	—
	.068 to .070 inch (Red)	—
	.083 to .085 inch (Black)	—
Reaction Shaft Support to Front Clutch Retainer (Selective)	—	.061 to .063 inch (Green)
	—	.084 to .086 inch (Red)
	—	.102 to .104 inch (yellow)
Sun Gear Driving Shell060 to .062 inch	—
Driving Shell (Steel)034 to .036 inch	—
Overrunning Clutch Race060 to .062 inch	—
Kickdown Annulus Support121 to .125 inch	—
Front Clutch to Rear Clutch043 to .045 inch	—
Front Clutch to Reaction Shaft Support043 to .045 inch	—
Output Shaft to Input Shaft	—	.062 to .064 inch
Sun Gear Driving Shell Thrust Plate (Steel)	—	.034 to .036 inch
Rear Planetary Gear to Driving Shell	—	.062 to .064 inch
Front Planetary Gear to Annulus Gear Support	—	.062 to .064 inch
Front Annulus Gear Support to Driving Shell	—	.062 to .064 inch
Front Clutch Piston Retainer to Rear Clutch Piston Retainer	—	.061 to .063 inch (Green)

SPEEDOMETER PINION CHARTS

TORQUEFLITE TRANSMISSIONS

A-727-A AND B

OUTPUT SHAFT DRIVE GEAR—8 TEETH

Tire Size	Axle Ratios			
	Number of Pinion Gear Teeth and Color			
	2.76:1	2.93:1	3.23:1	3.55:1
7.35-14	17-Orange	18-Dk. Purple	20-Green	18-Dk. Purple*
7.75-14	17-Orange	18-Dk. Purple	20-Green	18-Dk. Purple*
8.25-14	17-Orange	18-Dk. Purple	19-Dk. Blue	21-Gray
8.55-14	16-Brown	17-Orange	19-Dk. Blue	21-Gray
6.40-15	17-Orange			
6.70-15	16-Brown	17-Orange	19-Dk. Blue	21-Gray
7.10-15		17-Orange	19-Dk. Blue	21-Gray
7.50-15				19-Dk. Blue
7.60-15		17-Orange	18-Dk. Purple	20-Green

Axle Ratio 3.91:1, Tire Size 7.75-14 uses pinion 19-Dark Blue*

Axle Ratio 4.56:1, Tire Size 7.75-14 uses pinion 21-Gray*

*Use .8000:1 Ratio Adapter #2464421

SPEEDOMETER PINION CHARTS—(Continued)

TORQUEFLITE TRANSMISSIONS

A-727-A WITH 225 CU. IN. ENG.—

POLICE AND TAXI

OUTPUT SHAFT DRIVE GEAR—8 TEETH

Tire Size	Axle Ratios		
	Number of Pinion Gear Teeth and Color		
	2.93:1	3.23:1	3.55:1
7.35-14	18-Dk. Purple	20-Green	18-Dk. Purple*
7.75-14	18-Dk. Purple	20-Green	18-Dk. Purple*
8.25-14	18-Dk. Purple	19-Dk. Blue	21-Gray
8.55-14	17-Orange	19-Dk. Blue	21-Gray
6.70-15	17-Orange	19-Dk. Blue	
7.10-15	17-Orange	19-Dk. Blue	
7.60-15	17-Orange	18-Dk. Purple	

*Use .8000:1 Ratio Adapter #2464421

A-904-G AND A-904-LA

OUTPUT SHAFT DRIVE GEAR—7 TEETH

Tire Size	Axle Ratios				
	Number of Pinion Gear Teeth and Color				
	2.93:1	3.23:1	3.31:1	3.55:1	3.91:1
6.50-13	17-Orange	19-Dk. Blue		20-Green	21-Gray
6.70-13	16-Brown	17-Orange		19-Dk. Blue	21-Gray
7.00-13	17-Orange	18-Dk. Purple		20-Green	21-Gray
7.35-14	16-Brown	18-Dk. Purple	18-Dk. Purple	21-Gray	21-Gray
7.75-14	16-Brown	17-Orange	18-Dk. Purple	19-Dk. Blue	21-Gray
8.25-14	16-Brown	17-Orange	17-Orange	19-Dk. Blue	21-Gray
6.70-15	16-Brown	17-Orange	17-Orange	18-Dk. Purple	20-Green

MANUAL TRANSMISSIONS

A-903—3 SPEED

OUTPUT SHAFT DRIVE GEAR—7 TEETH

Tire Size	Axle Ratios				
	Number of Pinion Gear Teeth and Color				
	2.93:1	3.23:1	3.31:1	3.55:1	3.91:1
6.50-13	17-Orange	19-Dk. Blue		20-Green	20-Green*
6.70-13	16-Brown	17-Orange		19-Dk. Blue	21-Gray
7.00-13	17-Orange	18-Dk. Purple		20-Green	20-Green*
7.35-14		18-Dk. Purple	18-Dk. Purple	20-Green	21-Gray
7.75-14		17-Orange	18-Dk. Purple	19-Dk. Blue	21-Gray

SPEEDOMETER PINION CHARTS—(Continued)

Tire Size	Axle Ratios				
	Number of Pinion Gear Teeth and Color				
	2.93:1	3.23:1	3.31:1	3.55:1	3.91:1
8.25-14	16-Brown	17-Orange	17-Orange	19-Dk. Blue	21-Gray
6.40-15		17-Orange			
6.70-15		17-Orange	17-Orange	18-Dk. Purple	20-Green

*Use .9058:1 Ratio Adapter #2291141.

A-745—3 SPEED

OUTPUT SHAFT DRIVE GEAR—8 TEETH

Tire Size	Axle Ratios				
	Number of Pinion Gear Teeth and Color				
	2.93:1	3.23:1	3.31:1	3.55:1	3.91:1
6.50-13		19-Red		20-Black	22-Yellow
7.00-13	19-Red	21-Lt. Blue		22-Yellow	
7.35-14	18-Natural	20-Black	21-Lt. Blue	20-Black	22-Yellow*
7.75-14	18-Natural	20-Black	20-Black	20-Black*	22-Yellow*
8.25-14	18-Natural	19-Red	20-Black	21-Lt. Blue	21-Lt. Blue*
8.55-14		19-Red			
6.70-15	17-Lt. Purple	19-Red	20-Black	21-Lt. Blue	21-Lt. Blue*
7.10-15		19-Red			
7.60-15		18-Natural		20-Black	22-Yellow

*Use .9058:1 Ratio Adapter #2464240.

A-833—4 SPEED

OUTPUT SHAFT DRIVE GEAR—8 TEETH

Tire Size	Axle Ratios				
	Number of Pinion Gear Teeth and Color				
	2.93:1	3.23:1	3.55:1	3.91:1	4.56:1
6.50-13	19-Dk. Blue	21-Gray	19-Dk. Blue*	21-Gray*	
7.00-13	19-Dk. Blue	21-Gray	18-Dk. Purple*		
7.35-14	18-Dk. Purple	20-Green	18-Dk. Purple**		
7.75-14	18-Dk. Purple	20-Green	18-Dk. Purple**	19-Dk. Blue**	21-Gray**
8.25-14	18-Dk. Purple	19-Dk. Blue	21-Gray	19-Dk. Blue**	
8.55-14	17-Orange	19-Dk. Blue			
6.70-15	17-Orange	19-Dk. Blue	21-Gray		
7.10-15	17-Orange	19-Dk. Blue			
7.60-15	17-Orange	18-Dk. Purple			

*Use .8000:1 Ratio Adapter #2464421.

**Use .8000:1 Ratio Adapter #2464420.